

## EXPERIMENT PROCEDURE

- Verify Kirchhoff's laws for a circuit featuring resistors in series.
- Determine the overall resistance of a series circuit.
- Verify Kirchhoff's laws for a circuit featuring resistors in parallel.
- Determine the overall resistance of a parallel circuit.

## OBJECTIVE

Measure voltage and current in circuits featuring resistors in series and in parallel

## SUMMARY

Kirchhoff's laws are of key importance for calculating current and voltage in various parts of a circuit with multiple branches. In this experiment, Kirchhoff's laws will be verified by measuring voltage and current in various parts of circuits featuring resistors in series and parallel.

## REQUIRED APPARATUS

Quantity	Description	Number
1	Plug-In Board for Components	1012902
1	Resistor 220 Ω, 2 W, P2W19	1012912
1	Resistor 330 Ω, 2 W, P2W19	1012913
1	Resistor 470 Ω, 2 W, P2W19	1012914
1	Resistor 1 kΩ, 2 W, P2W19	1012916
1	Resistor 6.8 kΩ, 2 W, P2W19	1012921
1	Resistor 10 kΩ, 0.5 W, P2W19	1012922
1	Resistor 100 kΩ, 0.5 W, P2W19	1012928
1	Set of 10 Jumpers, P2W19	1012985
1	DC Power Supply 0 – 20 V, 0 – 5 A (230 V, 50/60 Hz)	1003312 or
	DC Power Supply 0 – 20 V, 0 – 5 A (115 V, 50/60 Hz)	1003311
2	Analogue Multimeter AM50	1003073
1	Set of 15 Experiment Leads, 75 cm 1 mm <sup>2</sup>	1002840

1

## BASIC PRINCIPLES

In 1845 *Gustav Robert Kirchhoff* formulated laws describing the relationship between voltage and current in electric circuits which include multiple branches. Kirchhoff's 1st law (current law or junction rule) states that at every point where a circuit branches the sum of the currents flowing towards the junction are equal to the sum of currents flowing away from it. His 2nd law (voltage law, loop or mesh rule) states that, for any loop in any closed circuit, the sum of the voltages in all the branches is equal to the overall voltage provided by the source to that loop. For such loops, a direction of flow is defined. Currents flowing around the loop in the defined direction and voltages which cause such current to flow are considered to be positive, whereas if the currents flow in the opposite direction they are considered to be negative, along with the voltages driving them. These rules can, for example, be applied to circuits featuring resistors in series or in parallel.

In a circuit with  $n$  resistors in series, the current  $I$  is identical at every point in the circuit. According to Kirchhoff's second law, the sum of the voltages across each resistor will be equal to the voltage of the source to which they are connected.

$$(1) \quad U = U_1 + \dots + U_n$$

Therefore the following applies with respect to the overall resistance  $R_{\text{ser}}$ :

$$(2) \quad R_{\text{ser}} = \frac{U}{I} = \frac{U_1 + \dots + U_n}{I} = R_1 + \dots + R_n$$

For a circuit featuring resistors in parallel, so-called nodes or junctions arise for the current. Measurements at those nodes show that the sum of the current flowing towards them is equal to the sum of the currents flowing away from them. The voltages at each of these nodes are identical. Kirchhoff's 2nd law makes it possible to determine unknown currents at a node. The sum of the currents flowing through the resistors in each branch is equal to the overall current  $I$ , whereby the following is true:

$$(3) \quad I = I_1 + \dots + I_n$$

Therefore the following applies with respect to the overall resistance  $R_{\text{par}}$ :

$$(4) \quad \frac{1}{R_{\text{par}}} = \frac{I}{U} = \frac{I_1 + \dots + I_n}{U} = \frac{1}{R_1} + \dots + \frac{1}{R_n}$$

In this experiment, series and parallel circuits both featuring three resistors are investigated. To verify Kirchhoff's laws, the overall current and the current in each section will be measured along with the overall voltage and the voltage in each section.

## EVALUATION

From the measurements on the series and parallel circuits, the overall resistance  $R$  is first to be calculated and then compared with the theoretical values obtained from equations (2) and (4).

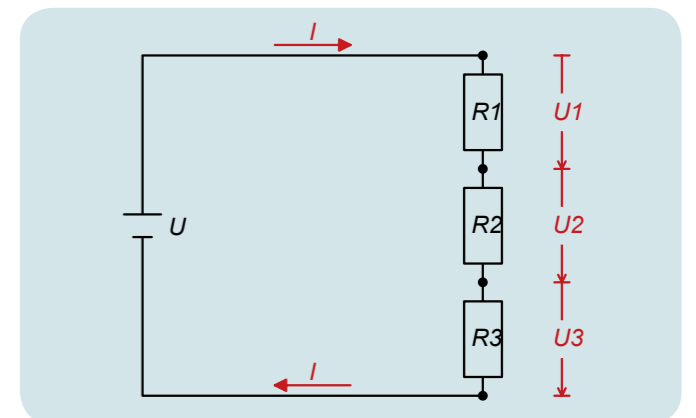

Fig. 1: Schematic for Kirchhoff's laws as applied to a circuit featuring resistors in series

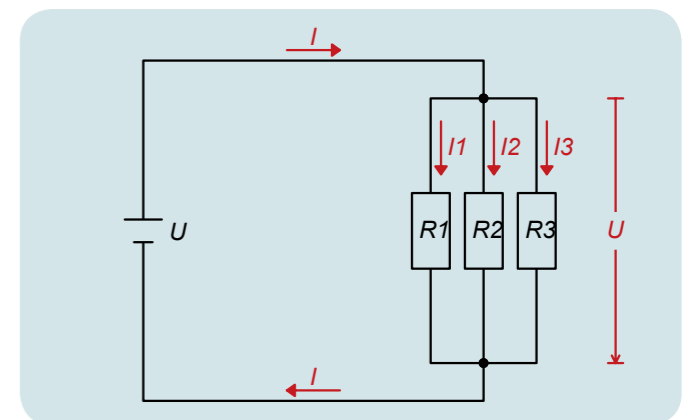

Fig. 2: Circuit diagram for a circuit featuring resistors in parallel