

Surface Tension

MEASURE THE SURFACE TENSION BY THE “BREAK-AWAY” METHOD.

- Form a lamella of liquid between a ring-shaped “blade” and the surface of the liquid by slowly lifting the ring out of the liquid.
- Measure the pulling force shortly before the liquid lamella breaks away.
- Determine the surface tension from the measured pulling force.

UE108040

08/08 JS

BASIC PRINCIPLES

The surface tension of a liquid is a property of the interface between the liquid and the air in contact with it. It results from the fact that a molecule of the liquid at the surface only experiences the forces from its neighbouring molecules at one side, whereas a molecule within the liquid experiences forces from all sides (see Fig. 1). Consequently, the molecule at the surface experiences a net force perpendicular to the surface towards the interior of the liquid. Therefore, in order to increase the surface area by bringing more molecules to the surface, a supply of energy is required.

The quotient

$$(1) \quad \sigma = \frac{\Delta E}{\Delta A}$$

resulting from energy ΔE added at a constant temperature divided by the increase in the surface area ΔA , is called surface tension or surface energy density.

To illustrate the meaning of this definition, consider the example of the ring-shaped “blade” which is initially completely immersed in the liquid. If the ring is slowly pulled out of the liquid, a lamella of liquid is also drawn upwards at its bottom edge (see Fig. 2). When the ring is lifted by an additional distance Δx , the total surface area of the lamella at the outside and inside of the ring increases by

$$(2) \quad \Delta A = 4 \cdot \pi \cdot R \cdot \Delta x,$$

where R is the radius of the ring.

For this, a force

$$(3) \quad F_0 = \frac{\Delta E}{\Delta x}$$

must be applied. If the force applied while lifting the ring exceeds F_0 , the liquid lamella breaks away.

In the experiment, a metal ring with a sharp lower edge hangs in a horizontal position from a precision dynamometer. At first, the ring is completely immersed in the test liquid (e.g. water), then it is slowly pulled upwards out of the liquid. The lamella of liquid breaks away when the pulling force F exceeds the limiting value F_0 .

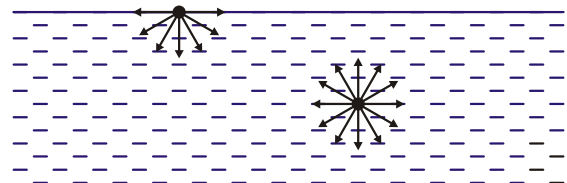

Fig. 1: Interaction forces exerted by neighbouring molecules on a liquid molecule at the surface and a molecule in the interior of the liquid

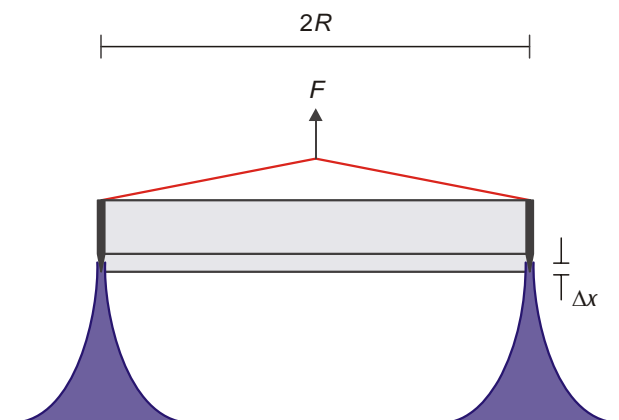

Fig. 2: Schematic diagram

LIST OF APPARATUS

1	Surface Tension Ring	U8412160
1	Precision Dynamometer 0.1 N	U20030
1	Beaker, from accessory set	U14210
1	Laboratory Jack II	U15020
1	Tripod Stand 150 mm	U13270
1	Stainless Steel Rod 470 mm	U15002
1	Clamp with Hook	U13252
1	Callipers, 150 mm	U10071

SET-UP

- Fill the beaker with distilled water and place it on the laboratory jack.
- Fix the clamp with hook onto the vertical rod and hang the dynamometer on it.



Fig. 3: Experiment set-up for surface tension measurements

EXPERIMENT PROCEDURE

- Adjust the laboratory jack to its maximum height.
- Measure the diameter of the ring and hang it on the dynamometer.
- Lower the clamp with hook together with the dynamometer and the ring until the ring is fully immersed in the water.
- Read off the force from the dynamometer and record it.
- Slowly lower the laboratory jack with the beaker until a lamella of liquid breaks away.
- At the instant of breaking away, read the force from the dynamometer and record it.
- Calculate the difference between the two forces.
- Repeat the measurement several times and check the reproducibility.

SAMPLE MEASUREMENTS

$d = 60 \text{ cm}$

Force with ring immersed: $F_1 = 0.033 \text{ N}$

Force at instant of breaking away: $F_2 = 0.065 \text{ N}$

Difference: $F_0 = F_2 - F_1 = 0.032 \text{ N}$

EVALUATION

From equations (1), (2) and (3),

$$F_0 = \frac{\Delta F}{\Delta x} = 4 \cdot \pi \cdot R \cdot \sigma$$

From this we obtain:

$$\sigma = \frac{F_0}{4 \cdot \pi \cdot R} = 85 \frac{\text{mN}}{\text{m}}$$