

## DC Power Supply 0 – 500 V

1003307 (115 V, 50/60 Hz); 1003308 (230 V, 50/60 Hz)

### Instruction sheet

04/12 ALF



- 1 Carrying handle
- 2 Ventilation slots
- 3 Voltage display
- 4 Zero adjustment for voltage display
- 5 Current limiter display (LED)
- 6 Voltage regulator
- 7 Earthing socket
- 8 Voltage output, 500 V
- 9 Voltage output, 50 V
- 10 Voltage output, 8 V
- 11 Voltage output, 12 V
- 12 Mains on/off switch
- 13 Power on display (LED)

### 1. Safety instructions

The 0 – 500 V DC power supply conforms to all safety regulations for electrical measuring, control, monitoring and laboratory equipment, as specified under DIN EN 61010, Section 1, and the equipment has been designed to meet protection class I. It is intended for operation in a dry environment, suitable for the operation of electrical equipment and systems.

Safe operation of the equipment is guaranteed, provided it is used correctly. However, there is no guarantee of safety if the equipment is used in an improper or careless manner.

If it may be assumed for any reason that non-hazardous operation will not be possible (e.g. visible damage), the equipment should be switched off immediately and secured against any unintended use.

In schools and other educational institutions, the operation of the power supply unit must be supervised by qualified personnel.



**Caution:** the low-voltage outputs of the power supply are not surge-proof if exposed to external voltages of more than 500 V with respect to earth.

- When using the equipment in conjunction with other power supplies, e.g. for operating electron tubes, be careful that no voltages

higher than 500 V with respect to earth are present at the outputs.

- Before using the power supply unit for the first time, confirm that the specifications printed on the rear side of the housing are compatible with the local mains voltage.
- Before using the power supply unit for the first time, check the housing and the mains lead for any damage. In the event of any malfunction/operational defect or visible damage, switch off the unit immediately and secure it against unintended use.
- The instrument may only be connected to the mains via a socket that has an earth connection.
- Before making any connections, check the experiment leads for damaged insulation and exposed wires.
- Replace a faulty fuse only with one matching the specifications stated at the rear of the housing.
- Disconnect the equipment from the mains before replacing a fuse.
- Never short the fuse or the fuse holder.
- Never cover the air vents in the housing. This is necessary to ensure sufficient circulation of air required for cooling the internal components of the equipment.

- The equipment may only be opened/repaired by qualified and trained personnel.

The 500 V output can be dangerous to touch.

- Switch off the equipment to start with while the experiment is set up.
- Any changes to the circuit may only be made with the equipment switched off.

## 2. Description

The 0 – 500 V DC power supply provides four independently adjustable DC voltages, and is especially intended for operating electron tubes, including Helmholtz coils.

The DC voltages are stabilized and regulated, floating and galvanically isolated from one another, short circuit proof and secure from external voltages. The output voltages are shown by four analogue displays.

The DC power supply 1003307 is for operation with a mains voltage of 115 V ( $\pm 10\%$ ), and the unit 1003308 is for operation with a mains voltage of 230 V ( $\pm 10\%$ ).

## 3. Technical data

### 500-V- output:

Voltage: 0 - 500 V DC, max. 50 mA  
 Stability at full load:  $\leq 0.01\% \pm 100\text{ mV}$   
 Residual ripple:  $\leq 20\text{ mV}$

### 50-V- output:

Voltage: 0 - 50 V DC, max. 50 mA  
 Stability at full load:  $\leq 0.1\% \pm 30\text{ mV}$   
 Residual ripple:  $\leq 5\text{ mV}$

### 8-V- output:

Voltage: 0 - 8 V DC, max. 3 A  
 Stability at full load:  $\leq 0.1\% \pm 30\text{ mV}$

### 12-V- output:

Voltage: 0 - 12 V DC, max. 4 A  
 Stability at full load:  $\leq 0.1\% \pm 30\text{ mV}$

Mains voltage: see rear of housing  
 Primary fuse: see rear of housing  
 Displays: analogue, class 2  
 Terminals: 4 mm safety sockets  
 Power consumption: 50 VA  
 Dimensions: 85 x 325 x 190 mm<sup>3</sup> approx.  
 Weight: 4 kg approx.

## 4. Operation

### 4.1 General information

- Before switching on the DC power supply, set all four voltage regulators to zero (turn fully to the left).
- Connect the power supply to the experimental setup.
- Do not switch the power supply on until the experiment has been fully assembled.

- Changes to the experimental setup must only be made with the power supply switched off.
- Set the required voltages.
- Before switching off the DC power supply, set the voltage regulators to zero again (turn fully to the left).

### 4.2 Changing the fuse

- Turn off the power switch and unplug the mains plug.
- Unscrew the fuse holder on the rear side of the housing with a screwdriver.
- Replace the fuse and reinsert the holder in its socket.

## 5. Care and maintenance

- Before cleaning the equipment, disconnect it from its power supply.
- Use a soft, damp cloth to clean it.

## 6. Disposal

- The packaging should be disposed of at local recycling points.
- Should you need to dispose of the equipment itself, never throw it away in normal domestic waste. Local regulations for the disposal of electrical equipment will apply.

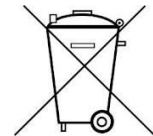

## 7. Examples of use

The 0 – 500 V DC power supply is especially suitable for use as a voltage source with the following tubes:

1. Fine beam tube 1024633
2. Training oscilloscope 1025250
3. Electron tubes in the S and D tube ranges:

	Series S	Series D
Diode	1000613	1000646
Triode	1000614	1000647
Gas triode	1000618	1000653
Dual beam tube	1000622	1000654
Thomson tube S	1000617	

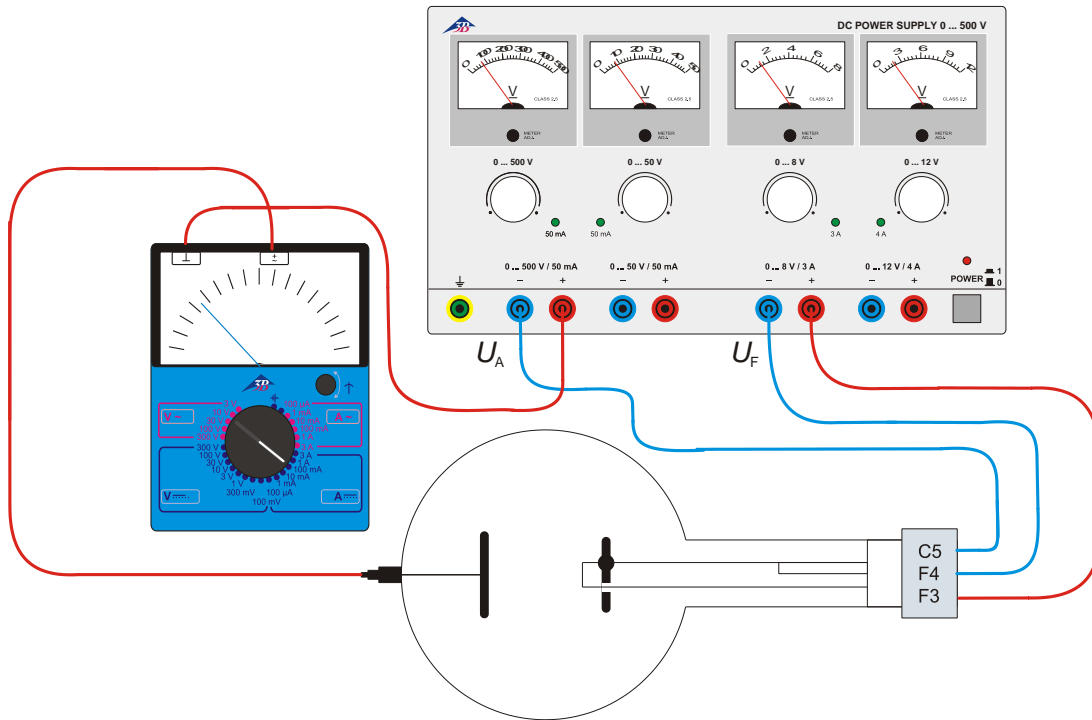

Fig. 1 Example of a circuit for the diode S (1000613): Determining dependency of anode current  $I_A$  on filament voltage  $U_F$  and confirmation of anode current  $I_A$  using a meter

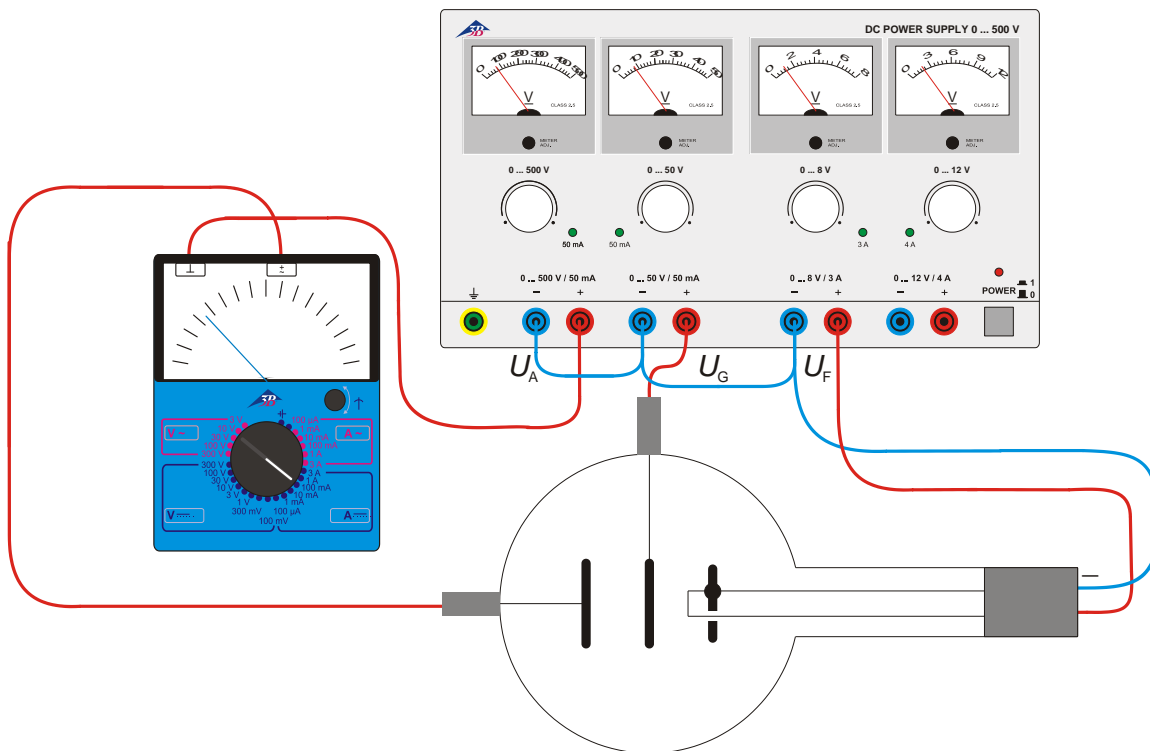

Fig. 2 Example of a circuit for the triode D (1000647): Recording the characteristics for a thermionic triode

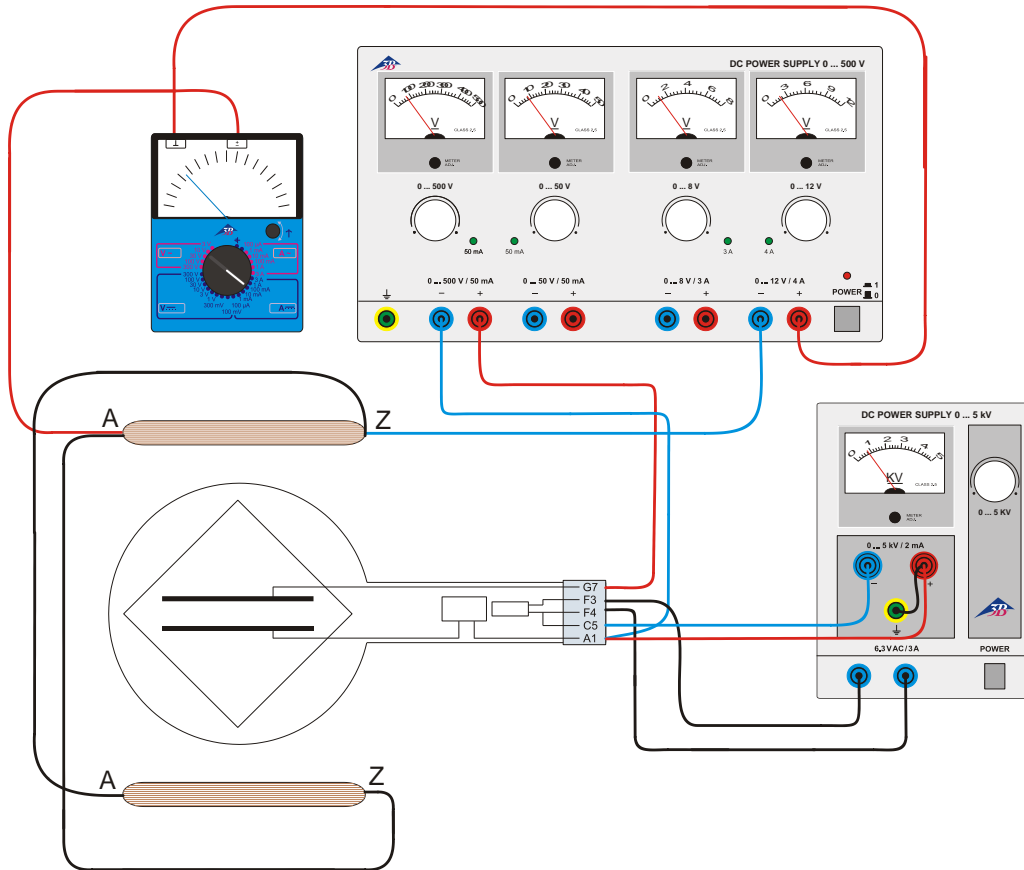

Fig. 3 Example of a circuit for the Thomson tube S (1000617): Determination of the specific charge  $e/m$  of an electron using the field compensation method

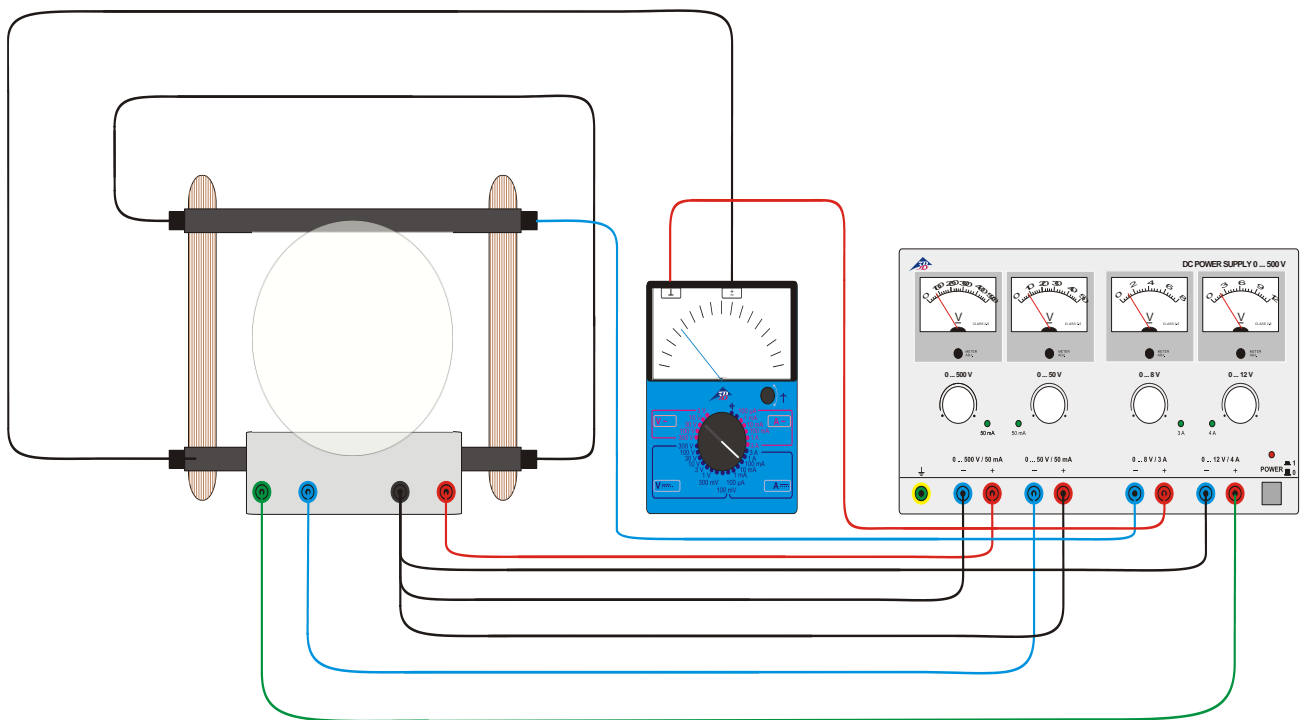

Fig. 4 Circuit for the fine beam tube (1024633): Determination of the specific charge  $e/m$  of an electron