

U10371 Electromagnetic experiment apparatus

Instruction sheet

9/04 MH

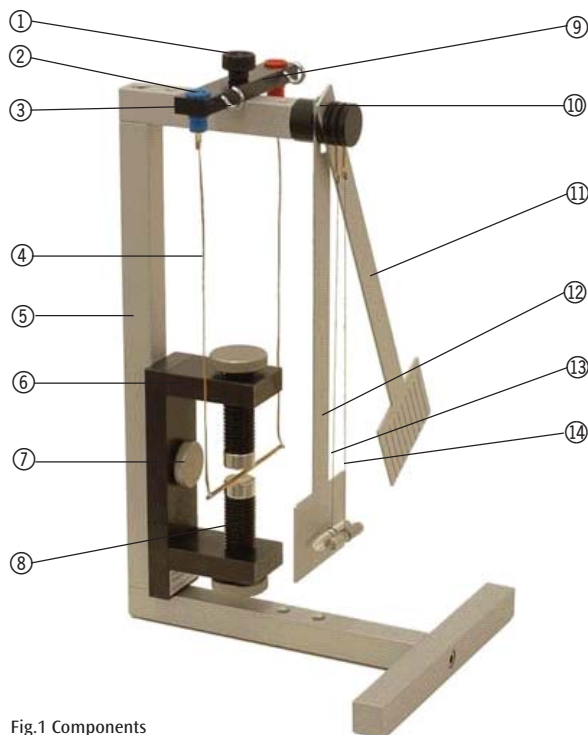

Fig.1 Components

- ① Knurled screws to fasten the cross bar
- ② Threaded holes (5x) to mount the cross bar
- ③ Cross bar
- ④ Conductor swing
- ⑤ Stand
- ⑥ M8x20 knurled screws for attaching magnet
- ⑦ Magnet U10370 (not included in scope of delivery)
- ⑧ Threaded holes to fasten magnet
- ⑨ Conductor swing suspenders
- ⑩ Pendulum axle mount
- ⑪ Slotted pendulum
- ⑫ Smooth pendulum
- ⑬ Glass rod with cord and hook
- ⑭ Aluminium rod with cord and hook

Using the electromagnetic experiment apparatus you can conduct experiments on the force on a current-carrying conductor, on induced eddy currents and on dia- or paramagnetism.

1. Safety instructions

- When using the magnet U10370, strict compliance with the safety instructions specified for this device is imperative, e.g. warning against use by persons with cardiac pacemakers!
- Electric shock hazard! The maximum output voltage of the mains power supply unit being used may not exceed 40 V.
- Burn hazard! The glass rod ⑬ is fragile and must consequently be handled with care. Sharp edges of broken glass give rise to a considerable risk of injury.

2. Description, technical data

The electromagnetic experiment apparatus consists of a rigid aluminium stand with preset magnet positions

and accessory mounts. This cuts out time-consuming adjustment work. Furthermore all accessory components can be fastened onto the stand for ease of storage. The pendulums (⑪, ⑫) should be suspended in the middle of the two slots of the pendulum mount and glass or aluminium rods (⑬ and ⑭) that the cords do not become tangled. The conductor swing hangs from a cross bar equipped with sockets for attaching safety plugs (4 mm). The maximum current flowing in the conductor swing should not exceed 6 A.

Height of stand:	345 mm
Pendulum:	290 x 70 mm
Slot width:	max. 1 mm
Width of conductor swing:	100 mm
Rods:	40 mm x 8 mm Ø

3. Operation and maintenance

- First the stand is screwed together as specified in Fig. 1. Make sure here that the apparatus is standing upright (triangular protractor).
- The braided copper strands of the conductor swing should hang smoothly down and the copper wire

should be held parallel to the cross bar. If necessary the copper strands can be carefully pulled between two fingers until they are smoothed out. In the region of the soldering points the copper strands should not be bent (danger of breakage).

- The glass and aluminum rod are each suspended on a thin thread, which might get somewhat twisted. Before starting an experiment the rods should hung individually on the stand until they are no longer twisted.
- Maintenance: the electromagnetic experiment apparatus is basically maintenance-free. To clean simply wipe over it with soap and water. Solvents like acetone, petroleum ether or ethanol (white spirit or alcohol) can be used except in the area of the label.
- If the cord of the glass or aluminium rod have become knotted or shredded, thin sewing silk can be used as a substitute. The sewing silk thread is first wrapped around the respective rod approx. 3 times and then tied in a knot. Then the rod is suspended and balanced out horizontally by moving the sewing silk thread along the rod. Finally the sewing silk thread is permanently attached to the rod using fast-acting adhesive (observe the safety instructions of the glue manufacturer).

4. Experiment procedure and evaluation

4.1 Current-carrying conductor in a magnetic field

4.1.1 Experiment setup

- The two possible experiment set-ups can be seen in Fig. 2.

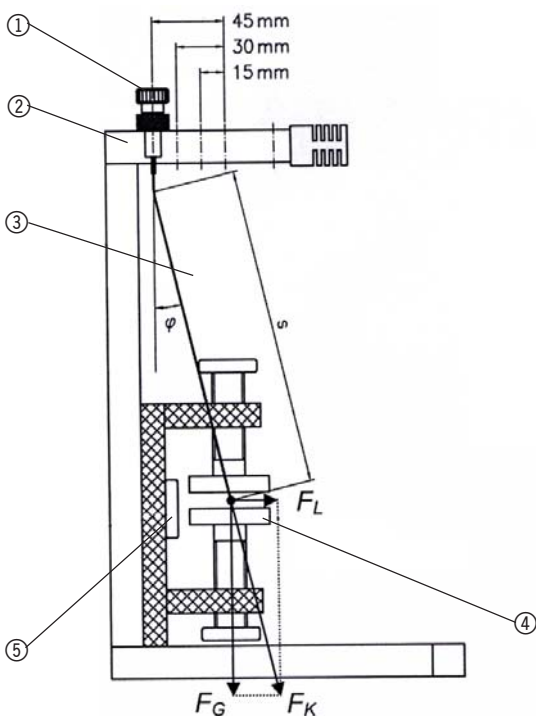

Fig. 2: Experiment setup "current carrying conductor in a magnetic field".

- ① Knurled screw, ② Cross bar, ③ Conductor swing, ④ Pole piece, ⑤ Flat headed knurled screw

- The experiment setup as specified in Fig. 2 (right) is used to verify that the Lorentz force acts neither in the direction of the magnetic field nor in the direction of current flow. In the first case the conductor swing would swing to the right or to the left, in the second case it would be forced to swing into or out of the plane of the drawing.
- Using the experiment setup specified in Fig. 2 (left) the Lorentz force can be demonstrated qualitatively and quantitatively. For the qualitative verification the conductor swing is suspended vertically above the poles of the magnet. When the current is switched on, we then observe deflection which gains in magnitude the more the current increases.
- For the quantitative determination of the Lorentz force the 3 threaded bore holes are used which are shifted at distances of 15, 30 and 45 to the left of the perpendicular holes. If, for example – as shown in the figure, the conductor swing is mounted shifted to the left by 45 mm and the current flowing through the conductor swing is set so that the copper wire is right in the middle of the magnetic field, then the swing's deflection from the vertical also amounts to precisely 45 mm and the Lorentz force corresponds to the returning force, which the conductor swing experiences due to the earth's gravity (see also experiment evaluation).

4.1.2 Experiment procedure

- During the measurements it is expedient to note down the following variables:
 - the experiment number,
 - the pole piece separation a ,
 - the pole piece width in the conductor direction b ,
 - the deflection c and
 - the current I , which flows when the copper wire is positioned in the middle¹⁾.

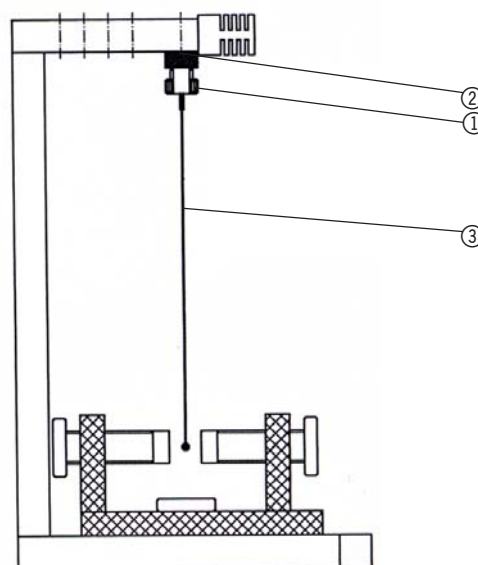

1) If necessary, measure the horizontal distance between the copper wire and the knurled screw (5) with a non-magnetic ruler

- Example of an experiment sequence:

Exp. no.	Pole piece separation a [mm]	Pole shoe width b [mm]	Deflection c [mm]	Current I [A]
1	10	50	15	0.57
2	10	50	30	1.20
3	10	50	45	1.87
4	10	20	15	1.16
5	10	20	30	2.36
6	10	20	45	3.57

4.1.3 Experiment evaluation

- The conductor swing is considered as a simple mathematical pendulum, i.e. the weight of the braided copper strands is neglected and the copper wire is seen as a point mass ($m = 6.23$ g). The effective pendulum length s is somewhat smaller than the length of the copper strands, due to the fact that these do not fold cleanly at the upper edges, when the conductor swing is deflected. The length s is thus the result from the theoretical point where the elongation of the linear copper strands intersects with the verticals (cf. Fig. 2). In approximate terms: $s = 200$ mm.
- The resulting force on the copper strand F_k is comprised of the Lorentz force F_L and the weight F_G and is inclined at an angle φ because the copper strand is (virtually) subject to no lateral forces. Consequently it is true that:

$$\frac{F_L}{F_G} = \tan \varphi$$

$$\Leftrightarrow$$

$$F_L = mg \frac{\frac{c}{s}}{\sqrt{1 - \left(\frac{c}{s}\right)^2}} \quad (1)$$

- In the above experiment sequence the pole pieces in experiments 4 - 6 were rotated by 90° in comparison to experiments 1 - 3. As such the conductor length which protrudes into the magnetic field changes. During the evaluation however, the true pole piece size may not be used as the basis because the magnetic field "bulges out" beyond the edges (see Fig. 3).

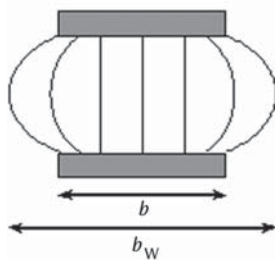

Fig. 3: Bulging effects at the edges of the pole pieces

- The resulting effective length within the magnetic field is approximately:

$$b_w = b + a \quad (2)$$

- The evaluation of the experiment series using Equations 1 and 2 yields the following:

Exp. no.	Effective conductor length b_w [mm]	Lorentz force F_L [mN]	Current I [A]
1	60	4.60	0.57
2	60	9.27	1.20
3	60	14.1	1.87
4	30	4.60	1.16
5	30	9.27	2.36
6	30	14.1	3.57

- The result is also depicted in Fig. 4. It is immediately discernible that the Lorentz force is proportional to the current. An evaluation of the linear gradients shows furthermore that the Lorentz force is also proportional to the effective conductor length. Consequently it holds true that:

$$F_L \propto b_w I$$

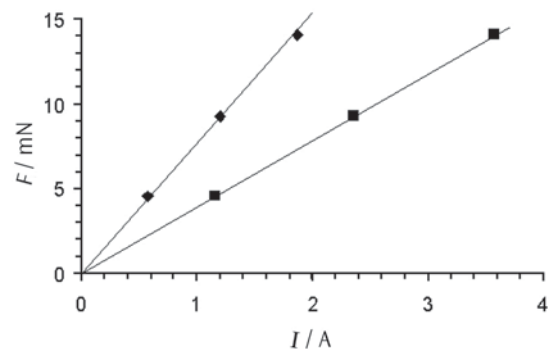

Fig. 4: Lorentz force as a function of the current flowing in the conductor. Square symbols: $b_w = 60$ mm, rhombuses: $b_w = 30$ mm

4.2 Induced eddy currents

- The experiment set up is depicted in Fig. 5. The pole gap amounts to approximately 10 - 30 mm and is varied. If both pendulums are jointly displaced by the same angle and then released, the

solid pendulum's swing is rapidly damped (braking) to a stop, whereas the slotted pendulum undergoes several swings first.

- Explanation: in the experiments in section 4.1 a current was flowing through the conductor swing. This brought about a movement of charges (electrons) in a magnetic field, which evidently led to a measurable force (the Lorentz force) acting on the electrons.



Fig. 5: Experiment set up for "induced eddy currents"

- In this experiment too, charges – free electrons in aluminum – are set in motion in a magnetic field, whereby the motion here is of a mechanical nature. Through this motion the Lorentz force also acts on the electrons, leading to a flow of electrons, i.e. a current flowing in the aluminium, which in this experiment flows vertically from top down or vice versa depending on the motion of the pendulum.
- In the solid pendulum there is a kind of "short-circuit" due to the fact that the induced current can flow back through the parts of the pendulum outside the magnetic field. This is how an eddy current arises, which can be very high and can lead to the build up of heat in the aluminium. The pendulum energy is initially converted into electrical energy and then into heat.
- In the slotted pendulum eddy currents cannot build up because the slots isolate the aluminium area outside the magnetic field from the area inside the field. Indeed the electrons here are also initially pushed in one direction or the other but once a great many electrons have collected at the

top or bottom of the pendulum they repulse each other with the result that the voltage generated is in equilibrium with the Lorentz force and current does not flow. Thus the pendulum energy is not converted into heat.

4.3 Dia- and paramagnetism

- The experiment setup corresponds in principle with Fig. 5. But now instead of suspending the pendulum we suspend either the aluminum or the glass rod in the magnetic field (prior to this please smooth out any twisted threads, see Section 3). The glass rod first starts to turn one way and then the other while the aluminium rod only very slowly (due to induced eddy currents, see last section) into its final position. After some time has elapsed the rods settle in the positions shown in Fig. 6.

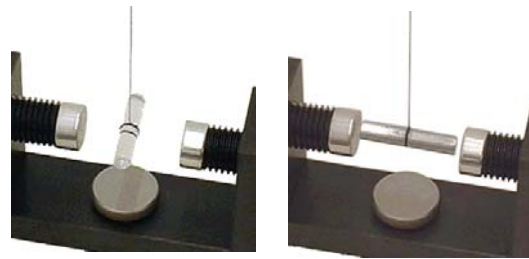

Fig. 6: Glass rod (left) and aluminium rod (right) in the magnetic field

- By loosening the knurled screw which holds the magnets and slowly turning the magnet it can be demonstrated that the orientation of the rods remain aligned relative to the magnets and that consequently the position cannot be attributed to the rest position emerging mechanically (caused by twisted threads).
- Explanation: although neither glass nor aluminium are magnetic, both rods align themselves in the magnetic field. The decisive variable here is the relative permeability μ_r . This specifies the factor by which the flux density of the magnetic field is multiplied within the material concerned, as compared to the flux in a vacuum. Surprisingly – and in contrast to dielectric constants – the relative permeability can be greater or smaller than 1. In aluminum $= 1.000023^{2)}$ and in glass $= 0.99999$. Thus in aluminum the flux density is amplified and the rod turns in the field direction. This effect is referred to as paramagnetism. In glass we have the opposite effect. The rod rotates out of the field and the effect is called diamagnetism.

²⁾ Grimsehl, Physik II, Ernst Klett Verlag Stuttgart, 1955