

Diode D 1000646

Instruction sheet

08/12 ALF

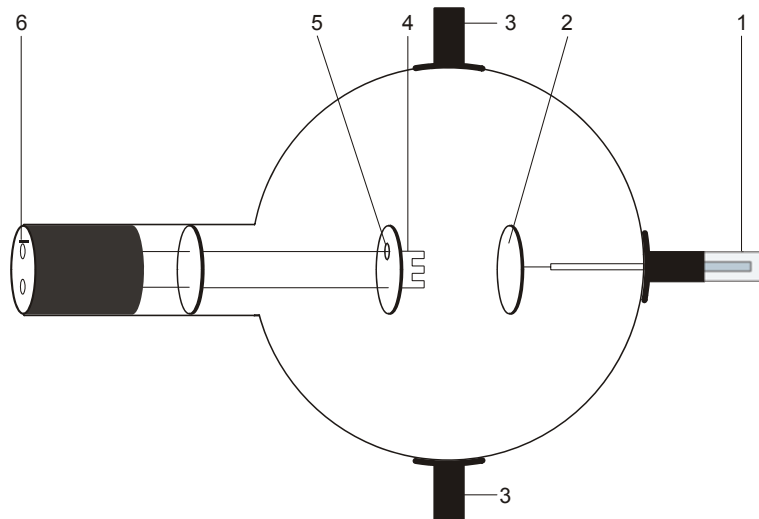

- 1 4-mm plug for connecting anode
- 2 .Anode
- 3 Boss
- 4 Cathode filament
- 5 Filament backing plate
- 6 4-mm sockets for cathode and filament

1. Safety instructions

Hot cathode tubes are thin-walled, highly evacuated glass tubes. Treat them carefully as there is a risk of implosion.

- Do not subject the tube to mechanical stresses.
- Do not subject the connection leads to any tension.
- The tube may only be used with tube holder D (1008507).

If voltage or current is too high or the cathode is at the wrong temperature, it can lead to the tube becoming destroyed.

- Do not exceed the stated operating parameters.
- When the tube is in operation, the terminals of the tube may be at high voltages with which it is dangerous to come into contact.
- Only change circuits with power supply equipment switched off.
 - Only exchange tubes with power supply equipment switched off.

When the tube is in operation, the stock of the tube may get hot.

- Allow the tube to cool before dismantling.

The compliance with the EC directive on electromagnetic compatibility is only guaranteed when using the recommended power supplies.

2. Description

The diode allows basic experiments to be performed on the Edison effect (thermionic effect), demonstrates how the emission current depends on the power supplied to heat the hot cathode, allows recording diode characteristics and shows the use of the diode as a rectifier.

The diode is a highly evacuated tube with a pure tungsten heater filament (cathode) and a circular metal plate (anode) inside a clear glass bulb. The cathode filament and the anode plate are parallel to one another. This planar configuration corresponds to the conventional symbol for a diode. A circular metal plate is attached to one of the filament leads. This ensures that the electric field between the anode and cathode is uniform.

3 Technical data

Filament voltage:	≤ 7.5 V
Filament current:	≤ 3 A approx.
Anode voltage:	max. 500 V
Anode current:	2.5 mA typical at $U_A = 300$ V, $U_F = 6.3$ V DC
Length of tube:	300 mm approx.
Diameter:	130 mm approx.
Distance between cathode and anode:	15 mm approx.

4. Operation

To perform experiments using the diode, the following equipment is additionally required:

1 Tube holder D	1008507
1 DC power supply 500 V (@230 V)	1003308
or	
1 DC power supply 500 V (@115 V)	1003307

Additionally recommended: Protective Adapter, 2-Pole	1009961
---	---------

4.1 Setting up the tube in the tube holder

- The tube should not be mounted or removed unless all power supplies are disconnected.
- Push the jaw clamp sliders on the stanchion of the tube holder right back so that the jaws open.
- Push the bosses of the tube into the jaws.
- Push the jaw clamps forward on the stanchions to secure the tube within the jaws.
- If necessary plug the protective adapter onto the connector sockets for the tube.

4.2 Removing the tube from the tube holder

- To remove the tube, push the jaw clamps right back again and take the tube out of the jaws.

5. Sample experiments

5.1 Generation of charge carriers by a hot cathode (thermionic effect) and measurement of the anode current in dependency on the power supplied to the cathode filament

Additionally required: 1 Analogue multimeter AM50	1003073
--	---------

- Set up the circuit as in Fig. 1. Connect the minus-pole of the anode voltage to the 4-mm socket marked with a minus.
- Start with the filament cold (filament voltage $U_F = 0$).
- Vary the anode voltage U_A between 0 and 300 V.

Practically no current (< 0.1 μ A) flows between the cathode filament and the anode, even at high voltages.

- Apply 6 V to the filament so that it gets hot, gradually increase the anode voltage and measure the anode current I_A .
- Set the filament voltage back to zero, let it cool, then gradually increase the filament voltage with a fixed anode voltage and observe the effect on the anode current.

When the filament voltage is fixed, the anode current increases in proportion to the anode voltage.

With the anode voltage fixed, the anode current increases in proportion to the filament voltage.

5.2 Recording diode characteristics

- Set up the circuit as in Fig. 1. Connect the minus-pole of the anode voltage to the 4-mm socket marked with a minus.
- Set filament voltages of 4.5 V, 5 V and 6 V.
- Determine how the anode current I_A depends on the anode voltage U_A for each of the filament voltages by raising the anode voltage step by step from 40 V to 300 V.
- Plot the values of I_A and U_A on a graph.

With increasing the anode voltage the anode current rises to an approximately steady value known as the saturation current.

With increasing the filament voltage the anode current rises.

5.3 Diode rectifier

Additionally required:

1 10 k Ω resistor
1 power supply for 16 V AC
1 oscilloscope

- Set up the circuit as in Fig. 3 with $U_F = 6.3$ V and $U_A = 16$ V AC
- Using an oscilloscope to measure the voltage across the 10 k Ω resistor, observe the rectifier operation of the diode

When the anode circuit operates as a diode, an AC voltage is rectified in that during one half of the current waveform the current is prevented from flowing.

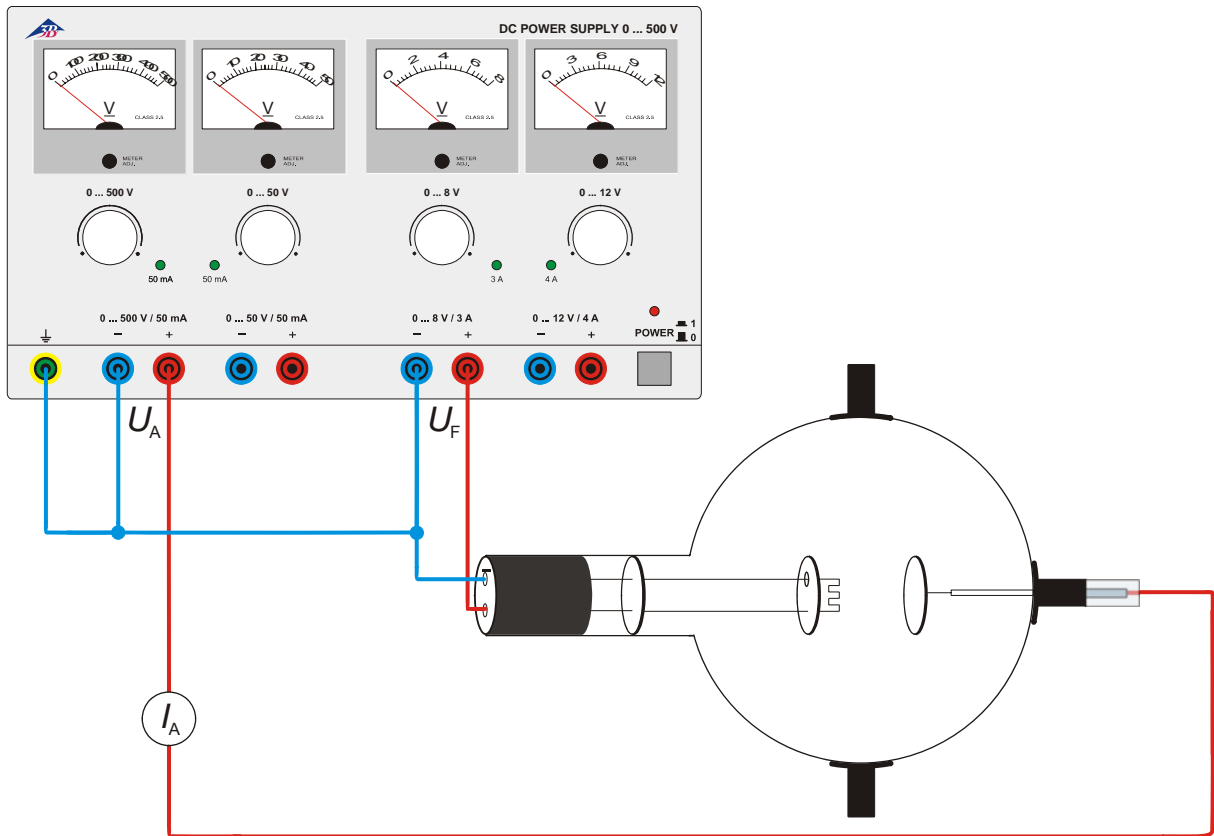

Fig. 1 Determining dependency of anode current on filament voltage. Anode current confirmed using a meter

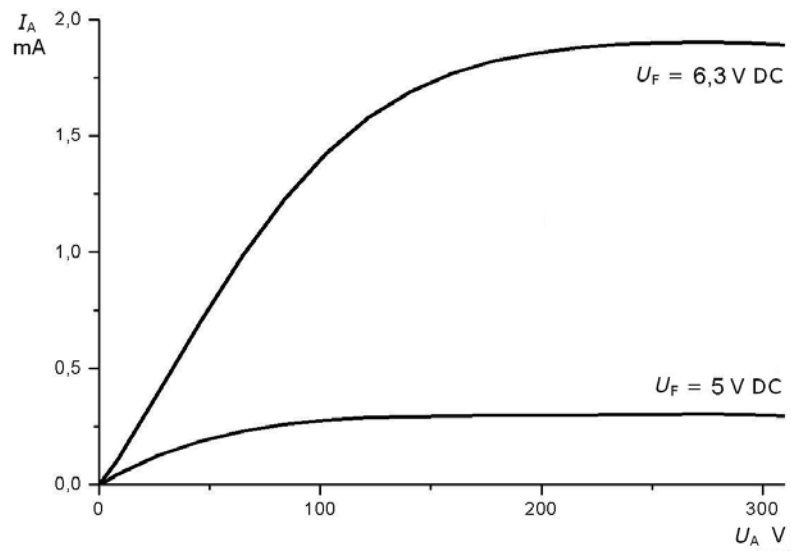

Fig. 2 Diode characteristics. Anode current as a function of anode voltage

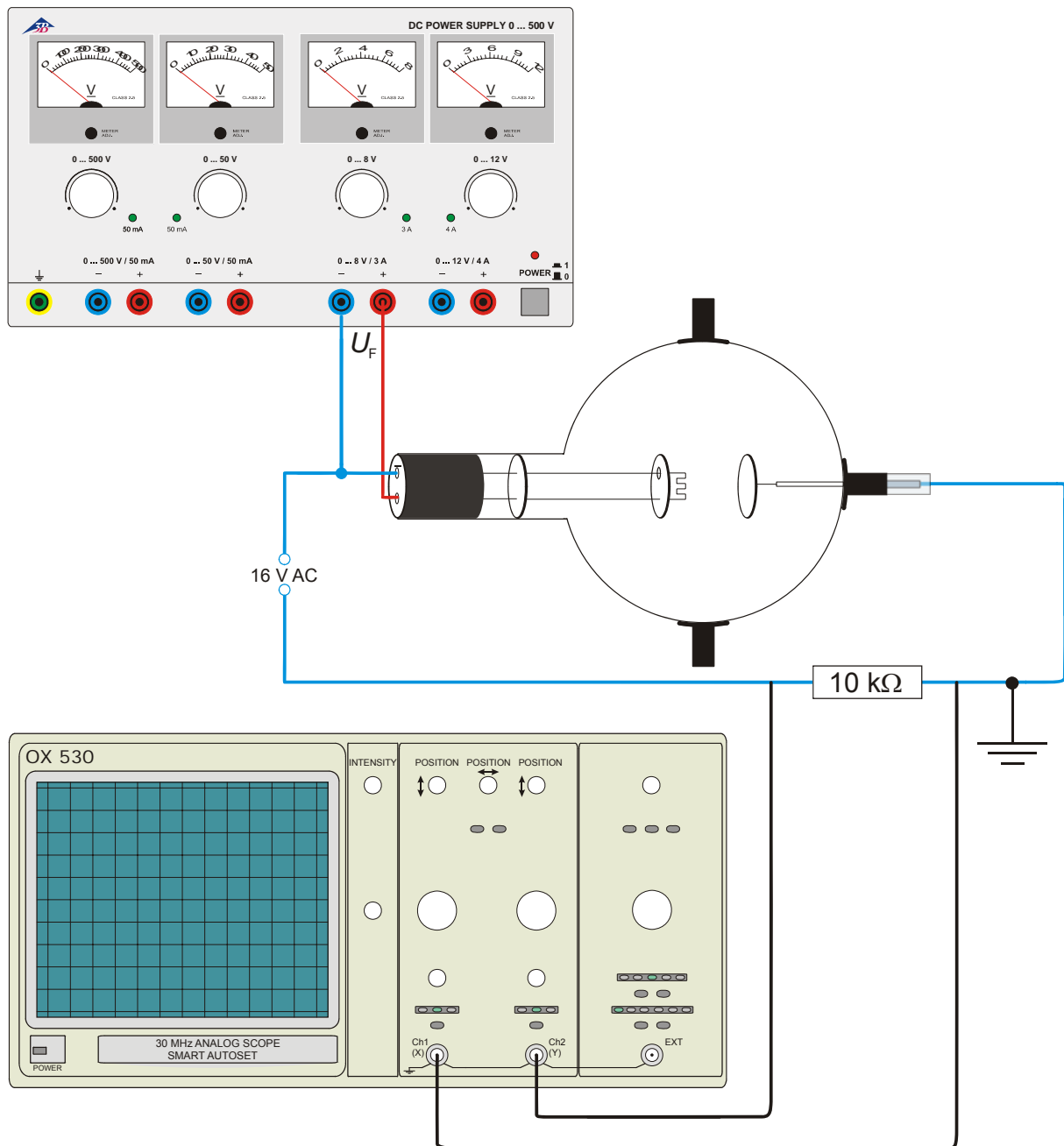

Fig. 3 Diode rectifier