

Air jet (Laminator) 8404250

Instruction sheet

08/06/DML



- 1 Pressure chamber
- 2 Single nozzle
- 3 Mounting stem
- 4 Air outlet ring

1. Description

The air jet is used in conjunction with a blower to generating an almost uniform flow of air, as required in experiments on fluid dynamics.

The plastic air jet consists of a hemispherical pressure chamber equipped with 50 single tubular nozzles which are arranged parallel to one another. The arrangement of the tubular nozzles has been specifically selected to ensure that the airflow generated by the blower exits the pressure chamber with a minimum of resistance and in such a way that the flow is evenly distributed among the tubes. Air blows out of the nozzles at high speed such that the moving flow is cylindrical in shape.

A ring runs around the ends of the nozzles and forms the actual outlet of the jet. As a result of the high velocity of the air flow, the static pressure around the nozzles is low. This means that surrounding air is sucked from the sides and into the high-speed flow. The combination of the air emerging directly from the nozzles and the air sucked in from the sides gives rise to a flow of air that is largely uniform and laminar. Any differences in the

velocity of the air flow which initially occur locally around the tubes do not have an adverse effect in most experiments and can hardly be detected at a distance of approximately 200 mm from the air outlet.

The air jet is equipped with a mounting stem by which it can be attached to a stand.

2. Technical data

Air inlet opening:	33 mm Ø
Air outlet ring:	120 mm Ø
No. of individual nozzles:	50
Individual nozzles:	4 mm Ø
Dimensions:	255 mm x 150 mm Ø
Weight:	350 g approx.

3. Operation

In order to conduct the experiments, a blower (8404240) is required.

The set of bodies for experiments on lift and drag (8404260) are ideally suited as test objects.

The component scale (8404261) is used to measure lift and drag.

Use simple filament probes to investigate the course of the airflow. It is very simple to construct a filament probe – take a thin wooden stick and tie one or more threads at equal distances from one another.

- Use the single bosshead (8613140) to fix the air jet vertically or horizontally to a stand rod (8611340).
- Use a table clamp (8612110) to set up the stand rod at the edge of the tabletop.
- Connect the air jet to the blower.

4. Sample experiments

4.1 Using a filament probe to investigate the course of airflow

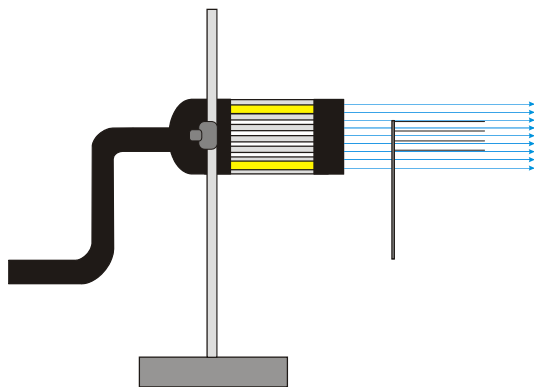

4.2 Using a component scale to measure the lift on a wing surface

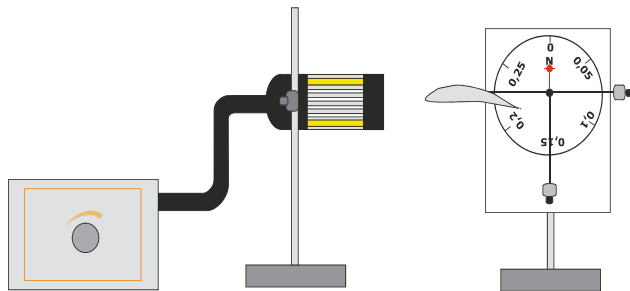

4.3 Using the component scale to measure the drag force on a disc

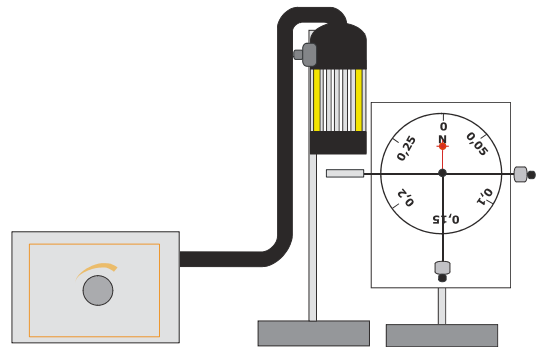

4.4 Determining the thrust of the air jet – experiment to model rocket and jet engines

