



SCIENCE EDUCATION

Visit us at 3bscientific.com

Anatomy • Biology • Chemistry • Health Education • Earth Science • Lab Equipment • Career Tech • Physics • Zoology



The
science of today
is the technology
of tomorrow.

– Edward Teller

At 3B Scientific we believe teachers, using our interactive models and experiments, will not only enable students to retain knowledge, but inspire and invoke a sense of curiosity in them.

A student may hear about the process of osmosis, but seeing it and interacting with it produces curiosity that drives them to expound upon it. It is in this advanced process that our world has gone from the light bulb to space exploration, from shamanism to modern medicine, from the earth being a flat surface to a globe tilting on an axis.

3B Scientific consists of a team of trained professionals who believe in the process of learning by demonstration and practice. We develop products of the highest fidelity to ensure that students understand science at its most fundamental level. We back these products with a knowledgeable service team here to answer all your questions and assist in any way possible. At 3B Scientific we strive to go one step further so that science can too.



Zach Montgomery
Managing Director

CONTENTS

| | |
|-----------------------|-----------|
| Anatomy..... | 2 - 59 |
| Health Education..... | 60 - 77 |
| Career Tech..... | 78 - 89 |
| Charts..... | 90 - 91 |
| Biology..... | 92 - 115 |
| Earth Science..... | 116 - 119 |
| Chemistry..... | 120 - 125 |
| Physics..... | 126 - 227 |
| Index..... | 228 |

FREE SHIPPING



Locate your **priority code** above your mailing address on the back cover (Example: SCI800) and enter the code during check-out for **Free Shipping** on orders over \$200.*

Ordering Information

Toll Free Phone: 1.866.448.5846
Toll Free Fax: 1.866.992.1514
E-mail: sales@a3bs.com
Order online at 3bscientific.com

The online *Quick Order* is fast and easy! Simply enter the product number and quantity online from the print catalog and go directly to the check-out.

Payment Methods

We accept Visa, MasterCard, Discover, American Express, personal checks, or money orders. Your card will only be charged when order is shipped.

Policies and Guarantees

Prices are subject to change. Our full ordering policies and manufacturer's warranty can be found online at 3bscientific.com.



You can find more products covering the topics introduced here on our web site.

*Free shipping is to a single continental US address only on orders over \$200. Freight shipments qualify for discounted shipping and certain other restrictions may apply.



HUMAN ANATOMY

3B Scientific has been setting quality standards in manufacturing didactic material for medical education since 1948.

Today, the brand is represented in over 100 countries worldwide with local offices in Brazil, China, France, Germany, Hungary, Italy, Japan, Russia, South Korea, Spain, Thailand, Turkey, United Kingdom and USA.

 3B Scientific Human Skull models now come with magnetic connections for easier disassembly. See page 26 for more details. Many more models come with convenient magnets – they are marked throughout the catalog with this icon.



3B Scientific offers you the highest level of service and product quality that you can always depend on. The production of our 3B Scientific® anatomy models, simulators and trainers is backed by the newest findings in medical sciences and educational techniques.

A wide selection of products is available to fit your exact needs:

- All life-size skeletons and some soft tissue models are cast from real specimens
- Made from extremely durable materials for everyday use
- Designed and developed in Germany for medical professionals

Precise anatomical details are hand painted to show intricate structures such as muscle and nerve fibres. These allow for easy identification in our detailed product manuals and learning cards whilst encouraging effective teaching and interactive study.

Only non-toxic material is used to create models for everyday, hands-on education. The casting process, from real specimens, guarantees realistic anatomical features and life-like textures. Our production processes ensure that our exacting standards are always maintained for every single bone, skeleton, model and simulator. This is backed by the 3B Scientific warranty.

3B Scientific is a member of the Worlddidac Quality Charter and its quality management is certified according to the standards of DIN EN ISO 9001.

The quality standards upheld in every 3B Scientific product are guaranteed by permanent and uncompromising controls.



Each model is hand-finished by highly trained and skilled technicians to ensure a consistently high quality.

SKELETON MODELS



Heavy Duty Metal Base

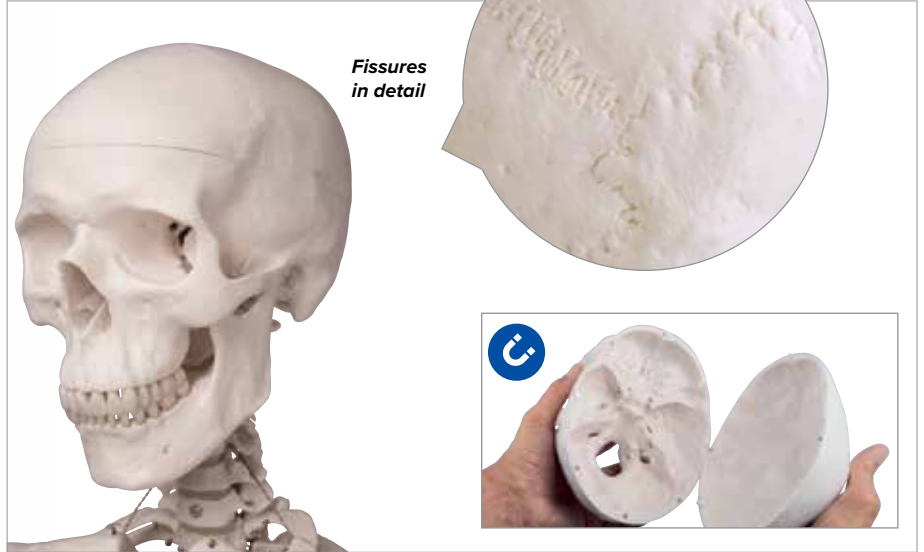

Fissures in detail

 **Magnetic connections for easy, hands-on demonstrations**

Stan the Classic Human Skeleton Model

The Classic Skeleton Model Stan has been the standard of quality in hospitals, schools, universities, and laboratories for over 50 years. Stan is the most affordable full-size skeleton of this quality available anywhere, ideal for active use in teaching and demonstrations. This human skeleton model is easy to handle, **anatomically correct** (cast from real specimen) and economically priced.

All 3B Scientific human skeleton models offer highest quality in workmanship and materials!

- Life-size and realistic weight
- Top quality cast from real specimens
- Extremely accurate in every detail, final assembly carried out by hand
- Made from a durable, unbreakable synthetic material
- 3 part assembled skull with magnetic connections
- Limbs can be removed quickly and easily
- Movable joints for demonstration purposes
- On a stable metal stand with 5 wheels for secure transfer from room to room
- Transparent dust cover included
- Developed in Germany

 **High quality human skeleton models, cast from a real specimen**

Stan on Pelvic Mounted Roller Stand

176.5 cm; 9.57 kg
1020171 \$375.00

Stan on Hanging Stand (not shown)

192.5 cm; 8.77 kg
1013857 \$514.00

Recommended: Heavy Duty Protective Cover, Black

Protect your investment with our heavy-duty protective cover. Suitable for all 3B Scientific full-size skeletons.
1020761 \$48.75



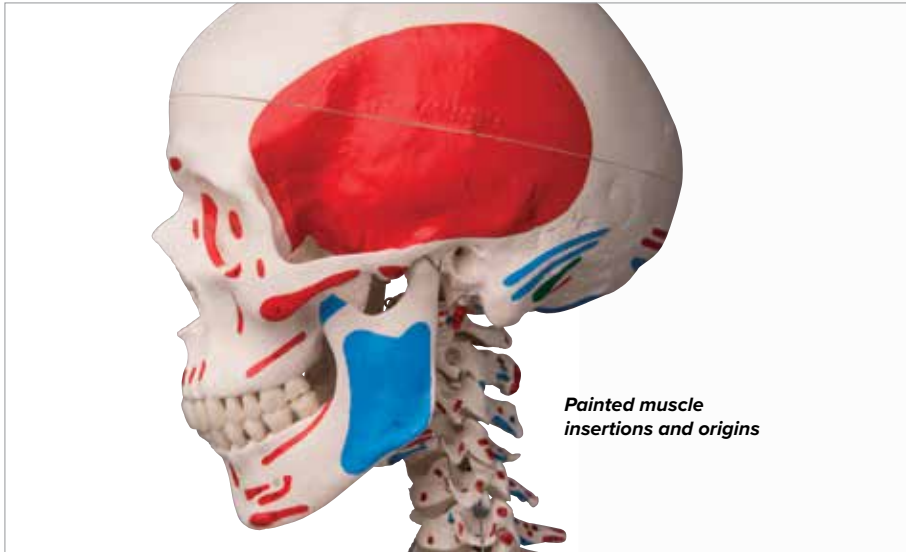

Painted muscle insertions and origins

Max the Classic Skeleton with Muscle Insertions and Origins

This skeleton contains all the standard benefits of a 3B Scientific® Skeleton **plus painted muscles**, to demonstrate the structural interaction between bones and muscles. It depicts over 600 structures of medical/anatomical significance including muscle origins (red) and insertions (blue) on the left side as well as hand numbered bones, fissures and foramina on the right side.

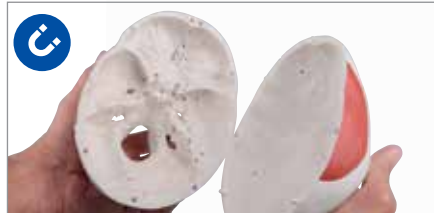

Max got muscle!

All features exclusive to Max at a glance:

- Shows the structural interaction between bones and muscles
- Depicts over 600 structures of medical significance
- Painted muscle origins in red and insertions in blue
- Hand numbered muscles, bones, fissures and foramina for easy identification



Demonstrate the structural interaction between muscles and bones with Max

Max on Pelvic Mounted Roller Stand

176.5 cm; 9.57 kg
1020173 \$809.00

Max on Hanging Stand (not shown)

192.5 cm; 8.77 kg
1020174 \$917.00



 **Magnetic connections for easy, hands-on demonstrations**

**Leo the Classic Skeleton
with Elasticated Ligaments**

This skeleton contains all the standard benefits of a 3B Scientific® Skeleton **plus ligaments** to represent the structural interaction between bones and ligaments. The elasticated ligaments on the major appendicular joints (shoulder, elbow, hip, and knee) are mounted on the right side.



Leo is all about ligaments!

All features exclusive to Leo at a glance:

- Structural representation of interaction between bones and ligaments
- All ligaments are elasticated to show movement

Leo on Pelvic Mounted Roller Stand

176.5 cm; 10 kg

1020175 \$916.00



Demonstrate the interaction between bones and ligaments and realistic movement with Leo

Elasticated knee ligaments





Sam is your all-purpose teaching tool for all levels of student or patient education



Over 600 labeled details



Emerging spinal nerves



Sam the Classic Skeleton with Elasticated Ligaments, Labels, Muscle Insertions and Origins

This skeleton contains all the standard benefits of a 3B Scientific® Skeleton **plus a bendable vertebral column, ligaments, painted muscles and over 600 labeled and identified structures**. Sam's fully flexible vertebral column allows you to **demonstrate all natural postures**, including the movements of the skull and head joints. The unique combination of a flexible vertebral column, muscle origins and insertions, numbered bones, flexible joint ligaments, and a disc prolapsed between the 3rd and 4th lumbar vertebrae allow you to display over 600 structures of medical/anatomical interest with this top of the line model. Comes complete with an identification guide.

Sam the Super Skeleton does it all:

- Over 600 hand-numbered, labeled details, includes detailed guide for easy identification
- Hand-painted muscle origins and insertions
- Flexible spine and ligaments for natural postures (can be removed from stand)
- Slipped disc between the 3rd and 4th lumbar vertebrae
- Protruding spinal nerves and vertebral arteries
- Full flexibility of limbs on left side, right side has full flexibility of knee and hip with limited flexibility of elbow and shoulder

Sam on Pelvic Mounted Roller Stand

176.5 cm; 10 kg
1020176 \$1,059.00

Sam on Hanging Stand

192.5 cm; 10 kg
1020177 \$1,107.00



Demonstrate natural movement and realistic joint mechanisms with Phil

Phil the Physiological Skeleton with Realistic Joint Mechanisms

Phil is unique in his near life-like realisation of the joint mechanisms. He allows you to demonstrate the inward and outward rotation of the arms and legs and the extension and flexion of the knee and elbow joints. The flexible spine allows for natural movement (lateral inclination, movement and extension, rotation). The bones of the hands are wire mounted to demonstrate their natural positions. The foot bones are mounted flexibly to enable movability. The shoulder blades rotate along when the arms are raised. Even the restricted mobility of the iliosacral joint and the sacrococcygeal joint can be demonstrated.

Phil moves! This skeleton has all the features of the Standard Classic Skeleton Model Stan, plus:

- The flexible spine allows for natural movement
- Near life-like realization of the joint mechanisms

Phil on Hanging Stand

192.5 cm; 9.6 kg
1020179 \$1,107.00



Demonstrate movement and fix any posture for detailed explanations with Fred

Fred the Flexible Skeleton with Extremely Bendable Spine

Fred's spine can be bent to mimic any natural human movement. Once flexed, it remains fixed in position to demonstrate correct and incorrect posture or various pathological conditions. In addition, all skull movements can be demonstrated. Spinal nerve exits and vertebral arteries are shown as well as a dorso-lateral disc prolapse between the 3rd and 4th lumbar vertebrae. Fred has all the standard benefits of a 3B Scientific Skeleton.

Fred on Pelvic Mounted Roller Stand

176.5 cm; 9.6 kg
1020178 \$696.00



Magnetic connections for easy, hands-on demonstrations





Demonstrate life-like movement unseen in any other skeleton model with Frank

Frank the Functional Skeleton for Life-like Movement

This unique functional Skeleton comes on a hanging stand and features a flexible assembly of all joints, allowing you to perform the individual movements in a nearly life-like way. You can even demonstrate the complex motions of the upper extremity. The shoulder blades rotate along when the arms are raised. Graphically demonstrate the position of the radial and ulnar bones during inward and outward rotation of the lower arm. The flexible spine allows for natural movement (lateral inclination, flexion and extension, rotation). Even the restricted mobility of the iliosacral joint and the sacrococcygeal joint can be demonstrated.

Frank's moves are truly unique. This skeleton contains all the features of the Standard Classic Skeleton Stan, plus:

- The flexible assembly of all joints lets you perform life-like movement
- Complex motions of upper extremities can be demonstrated

Frank on Hanging Stand

192.5 cm; 9.6 kg

1020180 \$1,443.00

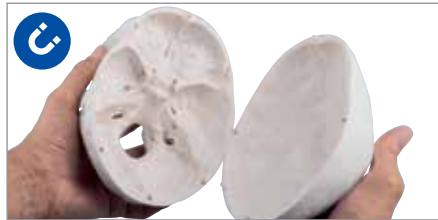

Magnetic connections for easy, hands-on demonstrations



Realistic patella movement





› Space saving miniature skeleton models

Shorty the Mini Skeleton

- Top of the range miniature human skeleton models.
- 3-part removable skull (skullcap, base of skull, mandible)
- Removable arms and legs
- Specially mounted hip joints to demonstrate natural rotation of the hips
- Made from durable, unbreakable plastic, hand assembled
- Can be taken off of the base when required

A. Shorty the Mini Skeleton, Pelvic Mounted

88 cm, 1.5 kg
1000039 \$240.00

Shorty the Mini Skeleton, Hanging Stand (not shown)

On hanging stand that can be placed on the floor or hung on the wall.

94 cm; 3.5 kg
1000040 \$286.00

B. Shorty with Painted Muscles, Pelvic Mounted

Muscle origins (red) and insertions (blue) on the left half.

94 cm; 1.7 kg
1000044 \$354.00

Shorty with Painted Muscles, Hanging Stand (not shown)

On hanging stand that can be placed on the floor or hung on the wall.

94 cm; 1.7 kg
1000045 \$413.00

Mini Skeletons: Incredible detail and fully articulating joints!

› More than measures up to the competition!



Mini Vertebral Column, flexible, on stand

Model with occipital plate of the skull, sacrum, coccyx, and intervertebral discs. The vertebral column is flexibly mounted to demonstrate natural movements and pathological changes. On a detachable stand.

- Scaled down replicas are big on details
- Lightweight for easy transport
- Compact when space is a concern

44 cm; 0.25 kg
1000043 \$136.00



Mini Skull, 3-part

Our mini skull precisely depicts all anatomical structures down to the last detail. Use it for education or as an office decoration. Can be disassembled into skullcap, base of skull, and mandible.

10 x 8 x 8 cm; 0.10 kg
1000041 \$39.00



Multifunctional Spinal Column Stand, 3-part (skeleton not included)

Dual purpose stand serves double duty; place it on a desk, the floor, or hang on a wall. Your choice!

1000132 \$65.00

Disassembled Skeleton Models for Detailed Study of Individual Bones



Labeled anatomical structures.
56: Fossa pterygoidea

Disarticulated Full Skeleton, Numbered with Muscle Origins and Insertions

This disarticulated 3B Scientific® Skeleton is hand-painted and numbered to show muscle origins in red and muscle insertions in blue on the left side. The disarticulated skeleton's bones and bony structures such as fissures, foramina and processes are hand-numbered on the right side. The skull is detachable into 3 parts for detailed anatomical study. Consists of 179 pieces.

- One hand and foot on wire
- Vertebral column strung on thin, nylon wire
- Multilingual product manual to identify over 600 numbered anatomical structures
- Supplied in a sturdy partitioned cardboard storage box

48,5 x 27 x 42,5 cm; 6 kg

1020158 \$745.00



This high quality skeleton replica is great for any in-depth study of the human skeleton and scientific anatomy studies.



Disarticulated Full Skeleton, Wire Mounted Hand/Foot

One hand and foot on wire, the others loosely articulated. Supplied in a sturdy partitioned storage box.

48.5 x 27 x 42.5 cm; 4.8 kg

1020157 \$446.00

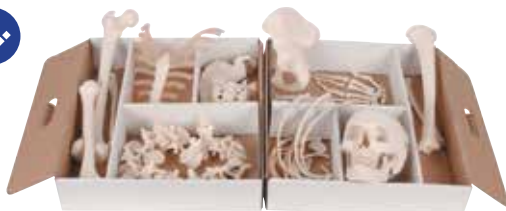

Disarticulated Half Skeleton, with Loose Hand/Foot

Complete with 3-part skull, sternum, hyoid and spinal column.

48,5 x 27 x 42,5 cm; 4 kg

1000024 \$376.00



Disarticulated Half Skeleton, with Wire Mounted Hand/Foot

Complete with 3-part skull, sternum, hyoid and spinal column.

49 x 43 x 26,5 cm; 4 kg

1020155 \$345.00

Benefits of flexibly mounted bone models:

The flexible bungee mounting enables the individual bones to be pulled back into their natural positioning after having been pulled apart for close up studies. The entire model will remain in its natural anatomical positioning when not pulled apart.



Loose Hand Skeleton with Ulna and Radius*

Loosely mounted on bungee string, Ulna
and Radius wire mounted.

1019369 \$115.00



Loose Foot and Ankle Skeleton (elastic bungee mounted)*

This loose foot and ankle skeleton comes mounted with elastic bungy
for a flexible effect. The foot skeleton includes portions of the tibia and
fibula with incredible detail cast from a real specimen.

1019358 \$106.00

Benefits of nylon mounted bone models:

The individual bones hold together in their anatomically correct location,
but are loosely enough mounted for individual studies.



Loose Hand Skeleton (nylon mounted)*

1019368 \$80.00



Loose Foot Skeleton (nylon mounted)*

1019356 \$82.00

Benefits of wire mounted bone models:

Once flexed, the joints stay in the position you choose for demonstration purposes. The individual bones will always remain in a natural anatomical position.



**A. Hand Skeleton
(wire mounted)*
1019367 \$66.00**

**B. Hand Skeleton with
Ulna and Radius*
1019370 \$95.00**

**C. Arm Skeleton*
1019371 \$107.00**

**D. Arm Skeleton with
Scapula and Clavicle*
1019377 \$120.00**

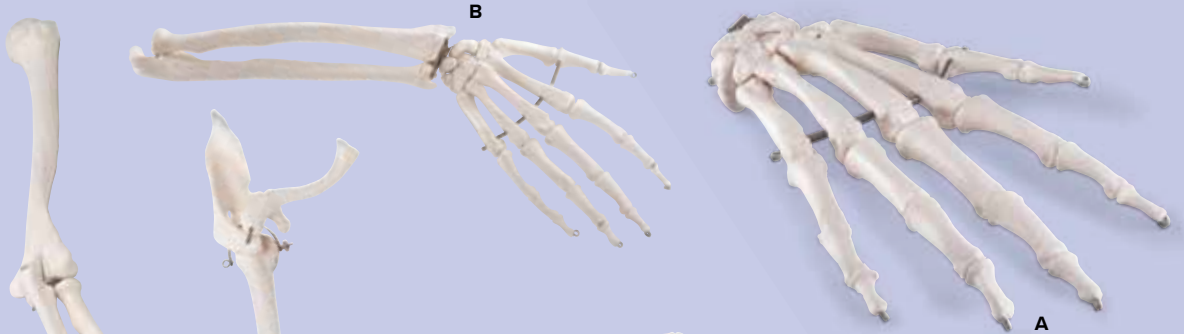

**E. Foot Skeleton
(wire mounted)*
1019355 \$66.00**

**F. Foot Skeleton
with Tibia and Fibula
(wire mounted)*
1019357 \$88.00**

**G. Leg Skeleton*
1019359 \$138.00**

**H. Leg Skeleton
with Hip Bone*
1019366 \$150.00**



*Please note that you will receive either a left or right version by default

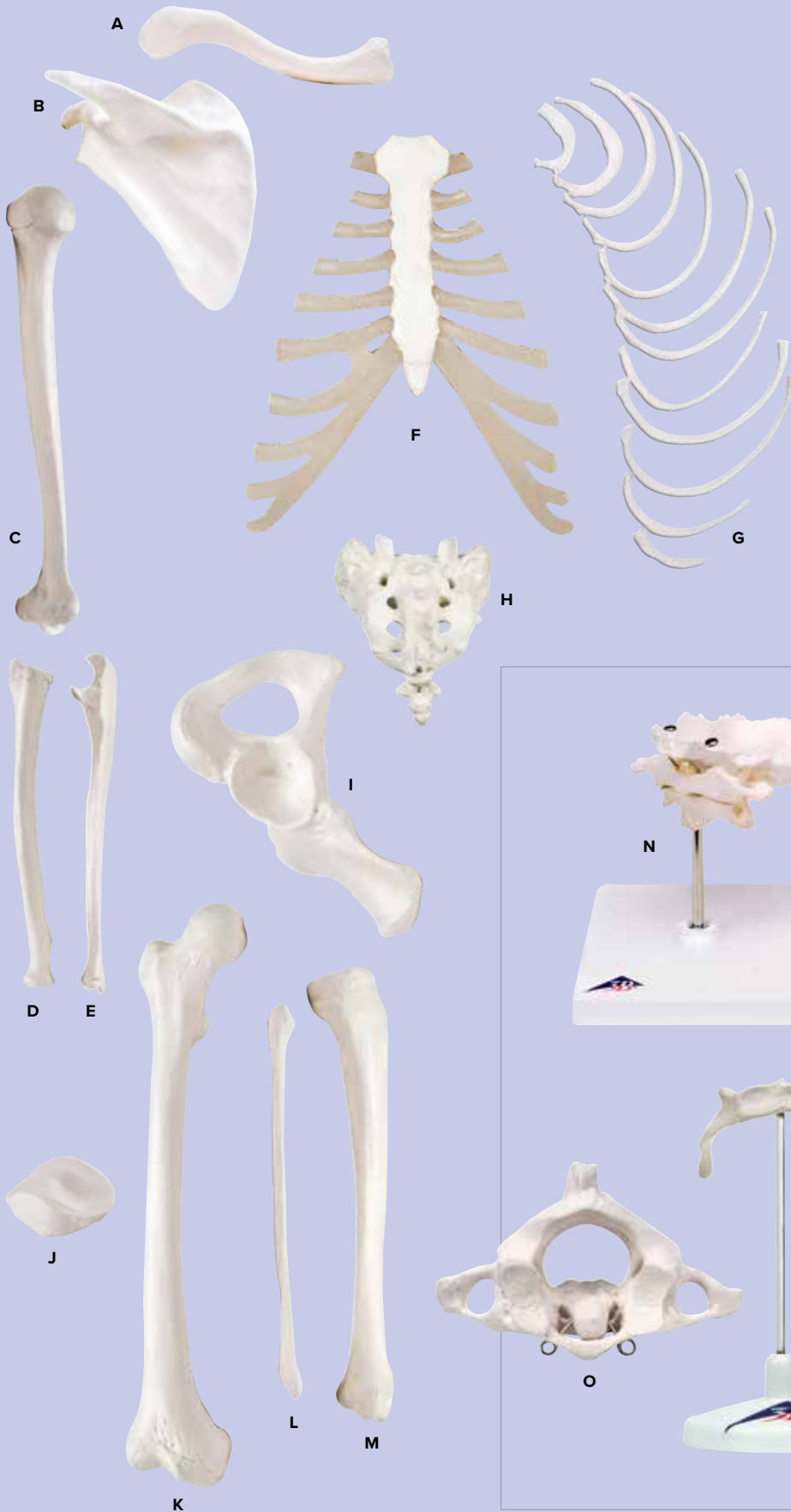

A. Scapula*
1019375 \$16.00

B. Clavicle*
1019376 \$16.00

C. Humerus
1019372 \$27.00

D. Radius
1019374 \$20.00

E. Ulna
1019373 \$20.00

**F. Sternum
with Rib Cartilage**
Replica human sternum
with rib cartilage.
1000136 \$37.00

G. Ribs*
12 individual ribs of one
side, unmounted.
1000137 \$59.00

H Sacrum and Coccyx
Assembled.
1000139 \$41.00

I. Hip Bone
1019365 \$29.00

J. Patella
1019362 \$22.00

K. Femur
1019360 \$43.00

L. Fibula
1019364 \$18.00

M. Tibia*
1019363 \$27.00

**N. Atlas and Axis,
with occipital plate**
Wire mounted together on
removable stand.
1000142 \$52.00

**O. Atlas and Axis,
wire mounted**
1000140 \$33.00

P. Hyoid Bone
Mounted on stand.
1000143 \$33.00

*Please note that you will
receive either a left or right
version by default



MICROanatomy™ Bone

Structure Model, enlarged 80 times

This model depicts a section of lamellar bone, showing the typical structure of tubular bone. Planes are shown in cross and longitudinal section through all levels of the bone and bone marrow. Typical elements are easily identified and help in understanding the structure and function of the Haversian systems. This representation graphically illustrates the individual bone components including spongy and compact substance, endosteum, cortical substance, osteocytes, Volkmann and Haversian canals.

26 x 19 x 14.5 cm; 1 kg

1000154 \$161.00



Cancellous Bone

The model shows the spongy bone inside the bone. Its filigree architecture is determined by influences such as pressure, bending and torsion. Using innovative micro CT technology, we have managed to reconstruct an exact 3-dimensional copy of a piece of cancellous bone from an original and enlarge it 100 times.

17 x 17 x 23 cm; 0.29 kg

1009698 \$410.00

HAND & FOOT MODELS



Structural Anatomy of the Hand, 3-part

Right down to the fingerprints, this full-size model shows amazing detail. The superficial and internal structures of the hand including bones, muscles, tendons, ligaments, nerves, veins, and arteries (superficial and deep palmar arches) are all present. The palmar aponeurosis and plate of the superficial flexor tendons are removable.

Analyze the palmar surface through three

increasingly deeper levels:

- 1st level: palmar aponeurosis.
- 2nd level: exposes the flexor retinaculum, superficial palmar arch, tendons of the flexor digitorum, and lumbricales muscles.
- 3rd level: uncovers the deep palmar arch, and deep layer of muscles, nerves, tendons, and ligaments.

28.5 x 13 x 6.5 cm; 1.2 kg

1000349 \$485.00



3 levels of amazing detail!

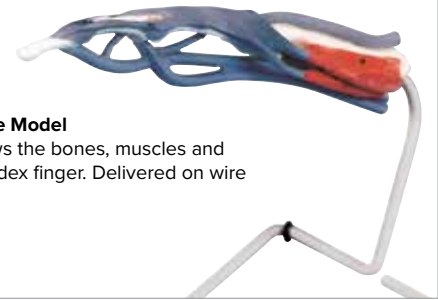

Internal Finger Structure Model

This full-size model shows the bones, muscles and tendons of the human index finger. Delivered on wire support stand.

19.5 x 13 x 19 cm; 0.5 kg

1000350 \$153.00



Single Foot Models

Superficial structures, as well as internal bones, muscles, ligaments and nerves of the human foot are shown in these high quality models.

A. Hollow Foot (Pes Cavus)

13 x 23 x 10 cm; 0.5 kg

1000356 \$99.00

B. Normal Foot (Pes Normal)

13 x 24 x 9 cm; 0.4 kg

1000354 \$99.00

C. Flat Foot (Pes Planus)

12 x 24 x 10 cm; 0.4 kg

1000355 \$99.00

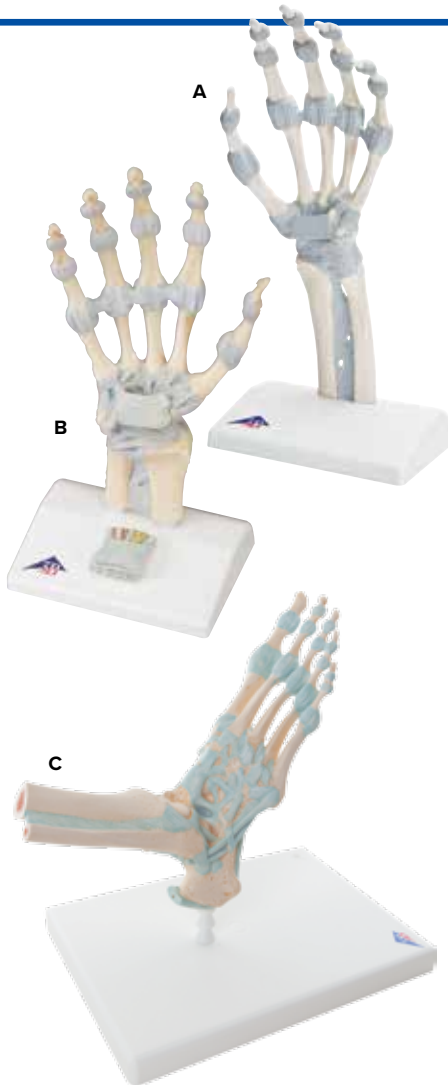

A. Hand Skeleton with Ligaments and Carpal Tunnel

This 3-part hand model shows the anatomical detail of the ligaments and tendons found on the hand, wrist, and lower forearm. The flexor retinaculum is removable and in addition there is a removable portion that can be fitted on the back of the model.

30 x 14 x 10 cm; 0.3 kg
1000357 \$242.00

B. Hand with Ligaments

This single-part model shows the anatomy of the ligaments in the hand in detail. It is ideally suited both as a teaching aid as well as for anatomy classes, such as for medical students, physiotherapists and occupational therapists.

1013683 \$359.00

C. Foot Skeleton with Ligaments

This detailed model displays numerous important ligaments and tendons including the Achilles and peroneus longus tendons of the ankle. 23 x 18 x 30 cm; 1 kg

1000359 \$242.00

► **Removable ligaments and muscles**

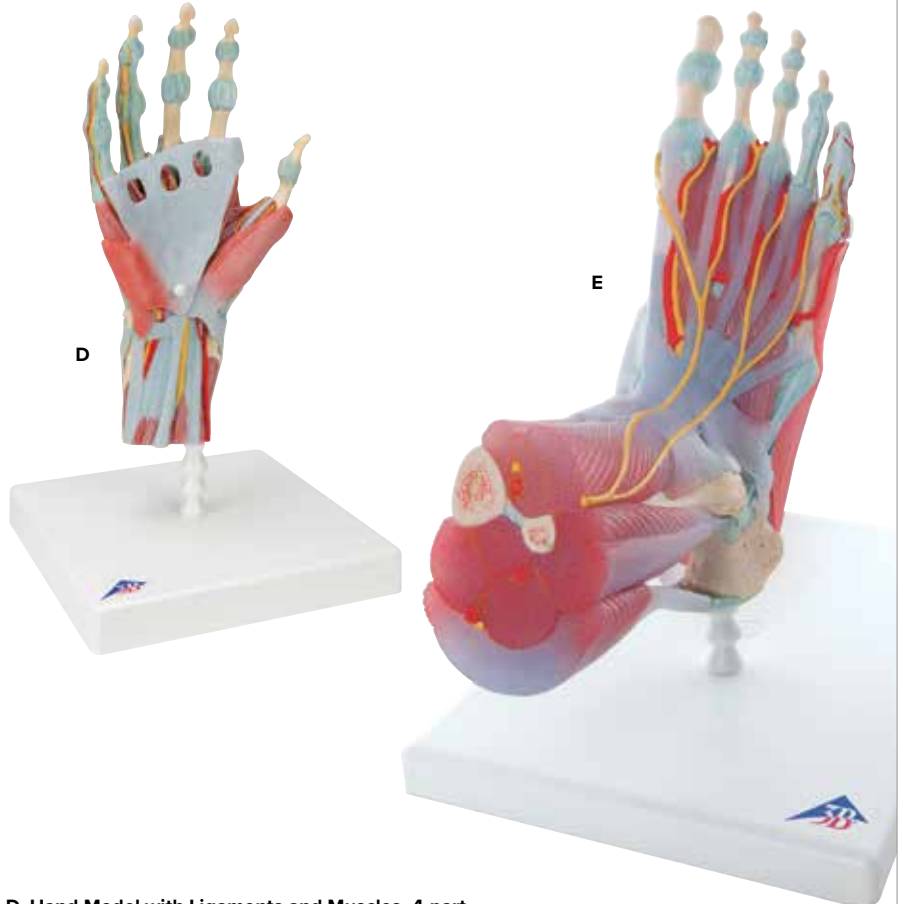

D. Hand Model with Ligaments and Muscles, 4-part

This high quality anatomically correct hand model with ligaments and muscles is great for detailed study of the hand and lower forearm.

All bones, muscles, tendons, ligaments, nerves, arteries, and veins are featured:

- Dorsal side: extensor muscles and portions of the tendons at the wrist passing under the extensor retinaculum
- Palmar face is represented in three layers, removable for detailed study of the deeper anatomical layer (median nerve, superficial palmar arch)
- Deepest anatomical layer shows the intrinsic muscles and deep palmar arterial arch

33 x 12 x 12 cm; 0.4 kg
1000358 \$353.00

E. Foot Model with Ligaments and Muscles, 6-part

This anatomically detailed model of the **foot and lower leg** can be disassembled into 6 parts for detailed study of the following structures: **bones, muscles, tendons, ligaments, nerves, arteries, and veins.**

The frontal view of the foot model features the extensor muscles of the lower leg. The tendons can be followed on their passage under the transverse and crucial crural ligaments all the way to their insertion points. In addition all tendon sheaths of the foot area are visible.

On the dorsal portion of the foot the gastrocnemius muscle is removable to reveal deeper anatomical elements. The sole of the foot is represented in three layers:

- The first removable layer displays the flexor digitorum brevis
- The second removable layer consists of the quadratus plantae, the tendon of the flexor digitorum longus, and the flexor hallucis muscle
- The third layer reveals even deeper anatomical details of the foot

23 x 26 x 19 cm; 11 kg
1019421 \$338.00

JOINT MODELS

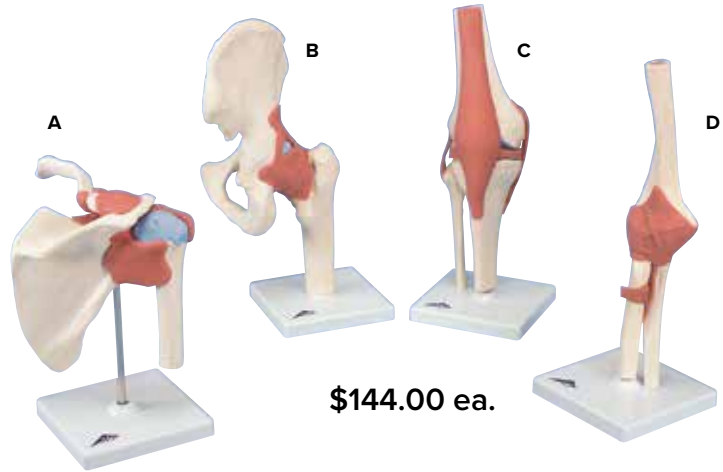
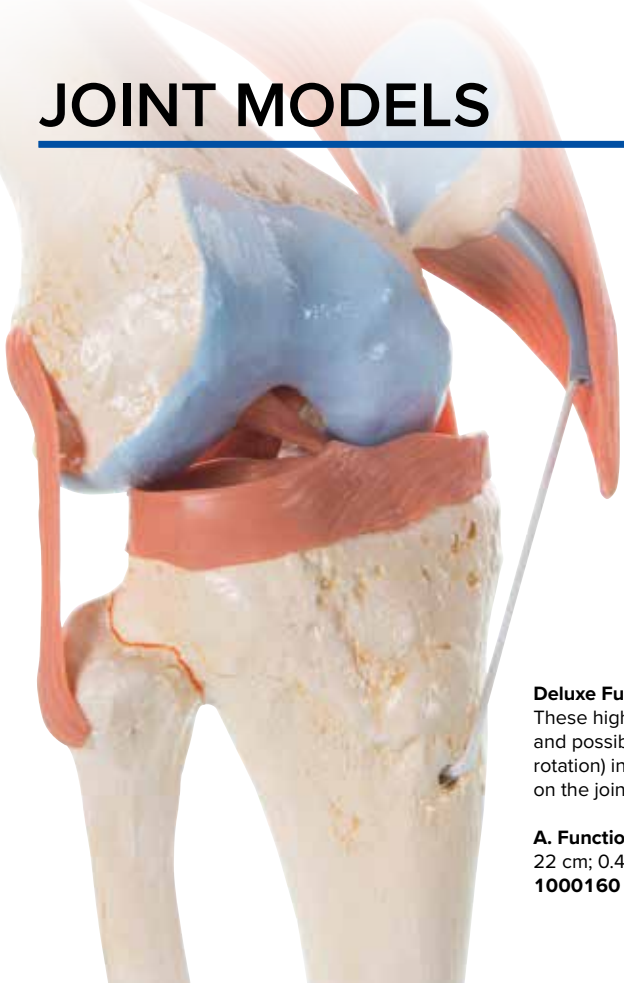

\$144.00 ea.

Deluxe Functional Joint Models

These high-quality functional models of naturally-sized right joints with ligaments show the anatomy and possible physiological movements (e.g. abduction, anteversion, retroversion, internal and external rotation) in exceptional detail. The color of the natural-cast bones is extremely realistic. The cartilage on the joint surfaces is marked blue.

A. Functional Shoulder
22 cm; 0.41 kg
1000160

B. Functional Hip
32 cm; 0.56 kg
1000162

C. Functional Knee
32 cm; 0.55 kg
1000164

D. Functional Elbow
33 cm; 0.28 kg
1000166

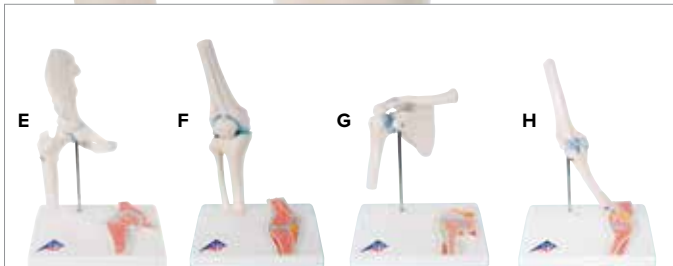

3B Scientific® Mini Joint Series with CrossSection

These mini-joints have been reduced to half their natural size but have kept all of their functionality. In addition to the external anatomical structures, using the superb joint crosssections mounted on the base, educators now have the ability to explain what is happening from "within".

E. Mini Hip
16 x 12 x 20 cm
1000168

F. Mini Elbow
16 x 12 x 20 cm
1000174

G. Mini Knee
10 x 14 x 24 cm
1000170

H. Mini Shoulder
12 x 14 x 16 cm
1000172

\$51.00 ea.

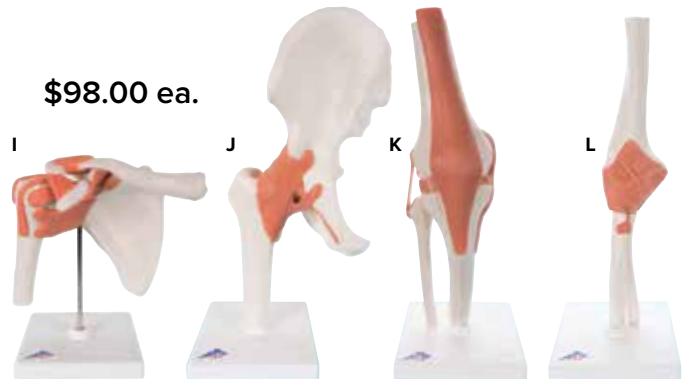
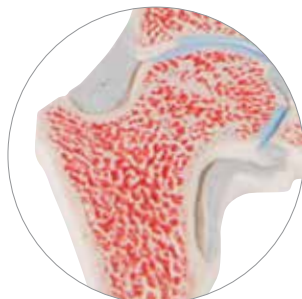

\$98.00 ea.

Classic Flexible Joint Models

Our classic joint models feature the same look and size as the deluxe models but without the natural bone coloring process and the blue paint representing cartilage.

I. Classic Shoulder
16 x 12 x 20 cm
1000159

J. Classic Hip
17 x 12 x 33 cm
1000161

H. Classic Knee
12 x 12 x 34 cm
1000163

I. Classic Elbow
12 x 12 x 39 cm
1000165





Sports Shoulder with Rotator Cuff, 5-part

This model comprises the upper half of the humerus, the clavicle and the shoulder blade. The muscles of the rotator cuff (subscapularis muscle, supraspinatus muscle, infraspinatus muscle, teres minor muscle) are displayed and the sites of origin and insertion of the shoulder muscles are highlighted in color (origin = red; insertion = blue). By removing the four individual muscles, all movements of the shoulder joint can be performed.

- Abduction
- Adduction
- Inward rotation
- Outward rotation
- Anteversion
- Retroversion
- Elevation
- Circumduction

18 x 18 x 24 cm; 0.9 kg
1000176 \$283.00



Femoral Fracture and Hip Osteoarthritis

At half natural-size, this model shows the right hip joint of an elderly person. Shown are the femoral fractures that occur most commonly as well as typical wear and tear of the hip joint. Also, a frontal section through the femoral neck is shown in relief on the base. On stand.

14 x 10 x 22 cm; 0.4 kg
1000175 \$90.00



Muscle Knee Joint, 12-part

Shows different removable muscles and muscle portions of the knee area. Color coded and raised areas indicate the muscle origin and insertion points on the femur, tibia, and fibula. In addition parts of the fibular and tibial collateral ligaments are represented. All the muscles of the leg are easily removable to permit study of the deeper anatomical layers.

33 x 17 x 17 cm; 1.8 kg
1000178 \$448.00



Hip Joint with Removable Muscles, 7-part

Right hip joint of an adult male with the individual muscles as well as the muscle origins and insertions on the femur and the hip bone. For educational purposes, the origin (red) and insertion areas of the muscles (blue) have been raised and presented in color. The hip muscles have been mounted on their corresponding regions of origin and insertion and are thus removable.

18 x 32 x 18 cm; 1.9 kg
1000177 \$383.00



Elbow Joint with Removable Muscles, 8-part

The right elbow of a male with individual muscles plus muscular origins and insertions on the humerus, radius, and ulna. For didactic reasons, the areas of the muscular origins (red) and insertions (blue) are raised and color-coded. The muscles can be attached to and removed from the corresponding areas of origin and insertion.

25 x 41 x 25 cm; 1.74 kg
1000179 \$391.00

3B BONElike™ MODELS

What is 3B BONElike™?

The 3B Scientific® unique material looks and feels like real bone. Each bone is an original cast of natural human bone with realistic weight, feel and appearance.

- Represents even the finest anatomical structures with realistic texture, color, and the porous characteristics of real human bone
- Makes an excellent alternative to real bone
- Great for use in medical teaching settings and in patient education



Vertebrae Sets

Nowhere else in the world can you find these realistic, high quality casts of original bones. They show even the finest anatomical structures in great detail.

30 x 21 x 6 cm; 0.3 kg

A. BONElike™ Cervical Vertebrae
Set of Seven
1000021 \$216.00

B. BONElike™ Lumbar Vertebrae
Set of Five
1000155 \$211.00



BONElike™ Flexible Vertebral Column

This true-to-life model of the human vertebral column is an excellent example of BONElike™ quality. This original, natural reproduction shows all anatomical details and has the realistic weight and feel of natural bone. Consists of the male pelvis and occipital plate. Occipital plate and atlas can be detached individually. Without stand.

85 cm; 1.5 kg

1000157 \$758.00

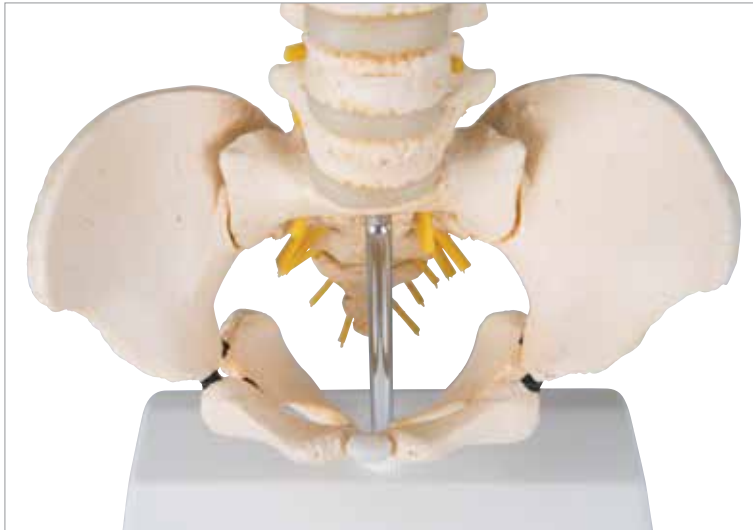

BONElike™

3B Scientific® BONElike™ Youth Vertebral Column

This true-to-life anatomical replica of the vertebral column of a child of about 5 years old is especially interesting for those working in the areas of anatomy, pediatrics, orthopedics and pediatric radiology. The unique material of the spine model makes it almost visually indistinguishable from a real vertebral column. The flexible vertebral column including occipital plate, pelvis and sacrocyx is mounted on a stand. Within the spinal canal, the spinal cord with cauda equina and exiting nerve roots are represented in flexible material.

See online for full description.

14 x 9 x 51 cm; 0.5 kg

1000118 \$293.00



Complete BONElike™ Vertebrae Set of 24

A complete set of 24 unmounted vertebrae delivered in a padded, easy-carry storage and travel case. 41 x 40 x 12 cm; 2.4 kg

1000156 \$675.00

VERTEBRAE & SPINE MODELS

➤ Fully flexible spine models for hands-on demonstrations!

All models of the classic series are of the highest quality, made of an extremely durable material for everyday use. They are anatomically correct and precisely detailed, and show even the finest structures. Flexibly mounted for more realistic demonstrations.



Other features of all spines in the Classic Series include:

- + Full pelvis and occipital plate
- + Fully flexible mounting
- + L3-L4 disc prolapsed
- + Spinal nerve exits
- + Cervical vertebral artery



Multifunctional Stand for Spinal Columns, 3 part

The stand can be placed on the floor or desk, or mounted on a wall. Measures 86 cm tall on a 24 cm square base.

0.75 kg

1000132 \$65.00



Classic Flexible Spine Model with Femur Heads

Same features as the Classic Flexible Spine, plus the femur heads. Male pelvis with femur heads.

83 cm; 2.1 kg

1000122 \$157.00

Classic Flexible Spine Model* (not shown)

Affordable spine model, extremely popular in medical education. Male pelvis.

74 cm; 1.8 kg

1000121 \$140.00



Classic Flexible Spine Model with Female Pelvis

This version comes with a **female pelvis** in addition to the features of the Classic Flexible Spine.

74 cm; 1.8 kg

1000124 \$186.00



Classic Flexible Spine Model with Femur Heads and Painted Muscles

Didactic benefit: muscle origins (red) and insertions (blue) are hand-painted on left innominate, femur and vertebrae. Otherwise same features as the Classic Flexible Spine.

83 cm; 2.1 kg

1000123 \$207.00



Didactic Flexible Spine Model with Femur Heads

Male pelvis with femur heads

82 cm; 2.1 kg

1000129 \$240.00

Didactic Flexible Spine Model (not shown)

Male pelvis

74 cm; 1.9 kg

1000128 \$212.00

Flexible positioning

Highly Bendable Spine with Soft Intervertebral Discs

This high quality spine model shows how the discs deform during normal and abnormal positioning. It is a valuable tool to demonstrate pathological conditions such as scoliosis, lordosis, kyphosis, or subluxations. Herniation of the vertebral column can also be demonstrated with compression. The model comes complete with spinal cord and spinal nerves. The special mounting allows a clear view during demonstration and display of the spine. Delivered on removable stand. 26 x 25 x 90 cm; 3 kg

1008545 \$342.00



Muscled Spine Model

This Muscled Spine Model was designed by internationally acclaimed anatomy sculptor John Mitchell. Use it to quickly and easily demonstrate the relationship between bones and muscles in the spine. The muscles are made of soft polyurethane rubber and are attached with a sturdy elastic cord to the spine with anatomically correct positioning.

1018411 \$403.13

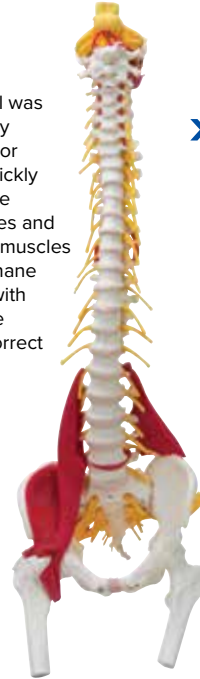

Demonstrate the connection and interaction of the spine with individual ribs!



Deluxe Series include:

- Sacral opening and exposed brain stem
- Extremely durable material for everyday use
- Full pelvis and occipital plate
- Fully flexible mounting throughout spine
- L3-L4 disc prolapsed on spinal column
- Spinal nerve exits
- Cervical vertebral artery
- Male pelvis



Deluxe Flexible Spine Model with Femur Heads

Male pelvis with femur heads
83 cm; 2.1 kg

1000126 \$240.00

Deluxe Flexible Spine Model (not shown)

Male pelvis
74 cm; 1.8 kg

1000125 \$216.00

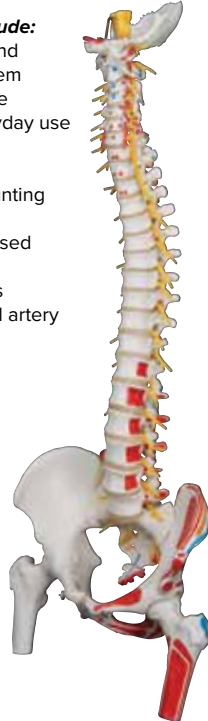

Deluxe Flexible Spine Model with Femur Heads and Painted Muscles

• Male pelvis with femur heads
• Hand-painted muscle origins and insertions on left innominate, femur and vertebrae
83 cm; 2.1 kg

1000127 \$267.00



Highly Flexible Spine Model with Femur Heads

Male pelvis with femur heads.
83 cm; 2.3 kg

1000131 \$258.00

Highly Flexible Spine Model (not shown)

Male pelvis.
74 cm; 1.4 kg

1000130 \$223.00



Classic Flexible Spine Model with Ribs and Femur Heads

Flexible spine model with ribs show the interaction of individual ribs with the spine and associated structures.

This model includes the following features:

- Movable mounted femur heads
 - Complete ribcage with individual mounted ribs
 - Full pelvis and occipital plate
 - Fully flexible mounting
 - L3-L4 disc prolapsed
 - Spinal nerve exits
 - Cervical vertebral artery
 - Male pelvis
83 cm; 3 kg
- 1000120 \$447.00**



5-Stages of Vertebral Degeneration

The model illustrates degenerative changes to the vertebral bodies and intervertebral discs of the lumbar spine in various degrees. Based on the original cast of a human lumbar spine, even the finest bone structures are accurately depicted. The model can be disassembled into vertebrae and intervertebral discs. Visit 3BScientific.com for representational conditions. Supplied on base.

22 cm; 0.5 kg
1000158 \$185.00



Deluxe Osteoporosis Model

Consists of three medially divided lumbar vertebrae with intervertebral discs. The upper section shows healthy bone structure, the middle section osteoporotic bone structure, and the lower section advanced osteoporotic bone structure with flattened plates, deformation and decreased mass. For detailed study the vertebrae can be removed from the stand.

16 cm; 0.25 kg
1000153 \$68.00

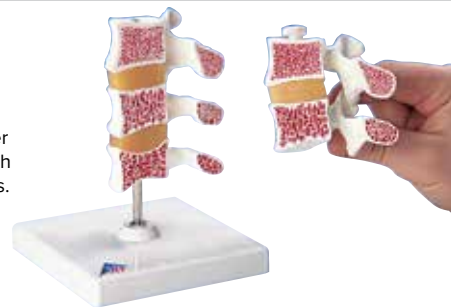

Anatomical Lifting Manikin

Clever engineering and assembly has produced a functional figure to provide a graphic demonstration of how the human spinal column reacts when heavy objects are lifted correctly and incorrectly. The manikin will lift a weight from either of two positions marked on the base. If the correct posture is used, the spine is undistorted. Incorrect posture exhibits obvious stress and distortion to the lumbar spine. Anatomical illustrations of the spine are featured on the base. Includes booklet with background information.

14 x 22.8 cm base; 42 cm tall when standing. 1.4 kg
1005101 \$487.00



Sectional Spinal Columns



Cervical Section

Consisting of occipital plate, the 7 vertebrae with discs, cervical nerves, vertebral arteries and spinal cord. On stand.
 19 cm; 0.3 kg
1000144 \$95.00



Thoracic Section

Consisting of the 12 thoracic vertebrae with discs, thoracic nerves and spinal cord. Flexibly mounted on stand.
 32 cm; 0.5 kg
1000145 \$95.00



Lumbar Section

Consisting of the 5 lumbar vertebrae with discs, sacrum with flap, coccyx, spinal nerves and spinal cord. On stand.
 34 cm; 0.6 kg
1000146 \$101.00



Lumbar Spinal Column with Dorso-Lateral Prolapsed Intervertebral Disc

The lumbar model includes a prolapsed inter-vertebral disc between the 3rd and 4th lumbar vertebrae. On stand.
 34 cm; 0.6 kg
1000150 \$127.00

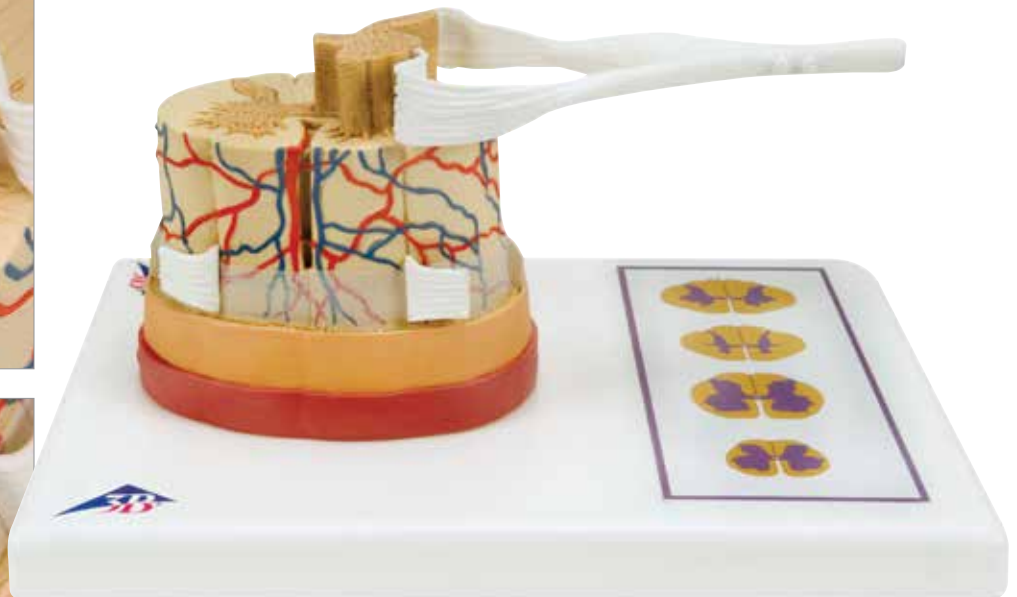
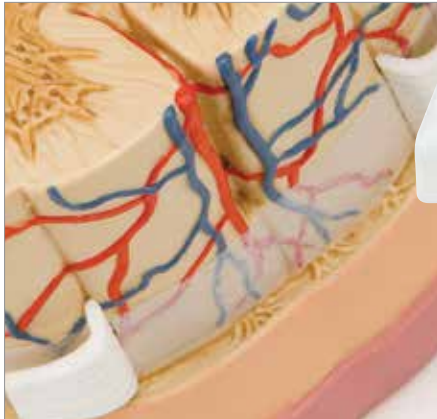
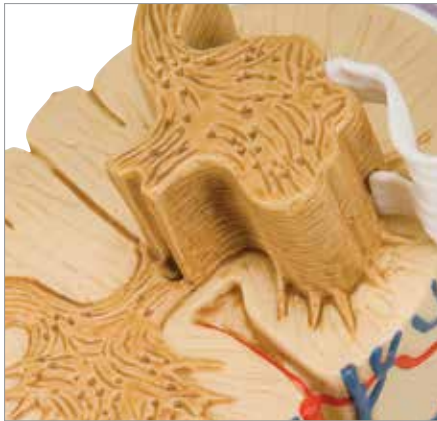

Spinal Cord with Nerve Endings

The construction of the spinal cord is shown through accurate representations of grey and white matter, fissures, nerve roots, the spinal ganglia, the spinal nerve with its four branches, and the three layers of the spinal column. The model is mounted on a base which has illustrations comparing cross sections from the cervical, thoracic, lumbar and sacral regions of the spinal column. The regions illustrated on the pedestal are color coded, numbered and explained in an accompanying product manual. 26 x 19 x 13 cm; 0.66 kg

1000238 \$254.00

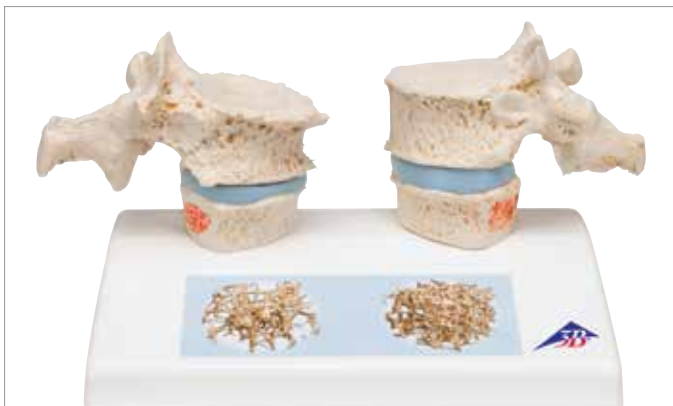

Lumbar Spinal Column with Prolapsed Intervertebral Disc

Natural casts of L4 and L5 lumbar vertebrae with paired spinal nerves, spinal cord and two interchangeable intervertebral discs. The discs illustrate either central or dorso-lateral prolapse. Dissects into 5 parts. On stand, removable. 26 x 19 x 14.5 cm; 0.38 kg

1000149 \$67.00

A. Three Lumbar Vertebrae, flexibly mounted

Anatomically correct to the last detail. Flexibly mounted with spinal nerves and spinal cord. 11 cm; 0.28 kg

1000151 \$43.00

B. Two Lumbar Vertebrae with Prolapsed Disc

Flexibly mounted with spinal nerves and spinal cord. 11 cm; 0.21 kg

1000152 \$39.00

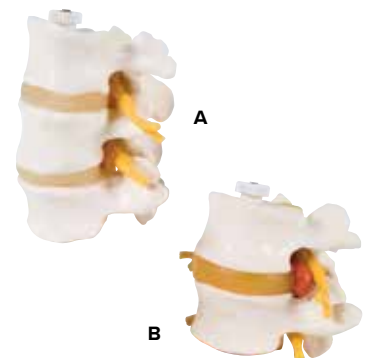

Osteoporosis Model

Impressive didactic model for comparing osteoporotic and normal thoracic vertebrae. Ideal for medical studies and patient consultation. Reproductions of osteoporotic thoracic vertebrae with narrower intervertebral disc are located on the left of the stand. Two corresponding healthy vertebrae with intervertebral disc are provided on the right side. The upper vertebra is divided in the middle. The magnetically attached vertebral half can be removed easily to show the cut surfaces. A detailed illustration on the base depicts two 3D micro CT images obtained from bone biopsies.

1000182 \$96.00

CLASSIC SKULL MODELS



Classic Skull, 3-part

The 3-part standard version A20 is a first choice for basic anatomical studies or an attractive medical gift. Alternatively, choose one of the more advanced versions with enhanced anatomical structures such as muscle origins/insertions, hand-numbered bones and structures, or a supplementary complete 5-part brain for more complex studies. 20 x 13.5 x 15.5 cm; 0.7 kg
1020159 \$110.00



Classic Skull, Painted, 3-part

The muscle origins (red) and insertions (blue) are shown in color on the left side of the skull. Cranial bones and structures are numbered on the right side. The skull identifies over 140 anatomical elements. 20 x 13.5 x 15.5 cm; 0.7 kg
1020168 \$164.00

Classic Skull, Painted, with Opened Lower jaw, 3-part (not shown)

Same features as A23, with exposed jaw. 20 x 13.5 x 15.5 cm; 0.7 kg
1020167 \$319.00



Classic Skull with Opened Lower Jaw, 3-part

In this highly detailed skull, the mandible is opened to show the dental roots with vessels and nerves. The cranial bones, bone components, fissures, foramina and other structures are numbered. The cranial sutures are shown in color, as are the meningeal vessels and venous sinuses. Over 100 features are identified in the accompanying product manual. 20 x 13.5 x 15.5 cm; 0.7 kg
1020166 \$232.00



Classic Skull, Numbered, 3-part

Hand-detailed version of our Classic Skull. Hand-numbered bones and features plus highlighted suture lines of the bony plates for ease in identifying all important anatomical structures. Includes product manual with key to numbered structures. 20 x 13.5 x 15.5 cm; 0.7 kg
1020165 \$149.00



Classic TMJ Skull with Masticatory Muscles, 2-part

Ideally suited for patient education, allied health instruction, anatomy studies, and as a medical-legal visual aid. This version of our Classic Skull has the masticatory muscles (masseter, temporal, medial and lateral pterygoid muscles) represented as elastic bands. Demonstrate the function of the masticatory muscles with jaw occlusion, the initial stage of jaw opening and the movements of the mandible to the side and front. The skullcap is removable. 20 x 13.5 x 15.5 cm; 0.9 kg
1020169 \$317.00



Classic Skull with soft 5-part Brain

All the features of Classic Skull A20 with a supplementary 5-part brain. This skull can be disassembled into skull cap, base of skull, and mandible. 20 x 13.5 x 15.5 cm; 1.5 kg

The components of its left half are:

- Frontal lobe and parietal lobe
 - Temporal lobe & occipital lobe
 - Ancephalic trunk
 - Cerebellum
- 1020162 \$278.00**

DIDACTIC SKULL MODELS



Human Skull Models on Cervical Spine, 4 part Flexibly mounted on the cervical spine

(C1, C2 and C7 are colored in the didactic version) to better show their relation. To complete this demonstration, the models also exhibit the hindbrain, spinal cord, spinal nerves of the cervical spine, vertebral arteries, basilar artery as well as the rear cerebral arteries.

Manufactured to the highest quality standards:

- Anatomically precise cast from original human skull
- Handmade from extremely durable, non-toxic plastic
- Highly accurate representation of the fissures, foramina, processes, and sutures
- Magnetic connections: can easily be disassembled into skullcap, base of skull and mandible

A. Didactic Human Skull Model on Cervical Spine, 4 part

This didactic skull model utilizes **19 distinctive colors to represent the shapes and relationships of the various bone plates** of the skull.

Mounted on stand.

17.5 x 17.5 x 30 cm; 0.6 kg

1020161 \$439.00

B. Human Skull Model on Cervical Spine, 4 part, naturally colored in bone like shades.

Mounted on stand.

20 x 13.5 x 15.5 cm; 0.6 kg

1020160 \$226.00



➤ **The most effective way to learn: hands-on with visual support!**

Beauchene Adult Human Skull Models, 22 part

The human skull consists of many individual bones that gradually grow together as the development proceeds. This human skull kit is a natural cast that makes the complex anatomical structures of the skull easy to understand. The skulls can be taken apart into the following 22 bones:

- Parietal bone (left and right)
- Occipital bone Frontal bone
- Temporal bone (left and right)
- Sphenoid bone
- Ethmoid bone
- Vomer bone
- Zygomatic bone (left and right)
- Upper jaw (maxilla) with teeth (left and right)
- Palatine bone (left and right)
- Nasal concha (left and right)
- Lacrimal bone (left and right)
- Nasal bone (left and right)
- Lower jaw (mandible) with teeth

C. Didactically Colored, 22 part

The 22 bones are depicted in 9 different didactic colors so that the individual skull bones are easy to distinguish.

21 x 14 x 16 cm; 0.7 kg

1000069 \$514.00



D. Bone Colored, 22 part

This version of the 22-part Beauchene skull has the same features as the didactic version, but is colored like natural bone.

21 x 14 x 16 cm; 0.7 kg

1000068 \$448.00



Deluxe Human Demonstration Dental Skull Model, 10 part

Exceptional quality and anatomical detail!

The skullcap is removable and the base of the skull is mid-sagittally divided. The anatomy of the human skull is easy to learn and teach using this model.

The model features the following details fitted with flaps that can be opened to view internal structures:

- Frontal sinus, perpendicular lamina and vomer can be opened to view the lateral nose wall and sphenoidal sinus
- Left side temporal bone can be removed and folded up in the area of the tympanic membrane
- Maxilla and mandible of the skull are opened to reveal the alveolar nerves
- Right side the temporal bone is opened to reveal the sigmoid sinus, the facial nerve canal and the semicircular ducts
- Right side flap at maxillary sinus and the right half of the mandible, so that the dental roots of the premolars and molars of the lower jaw can also be viewed

The natural occlusion and the individual removal and replacement of each tooth also make this skull especially interesting for dentists. This is a spectacular model whether you use it as a dental skull or for other purposes.

28 x 22.5 x 18.5 cm; 1.5 kg
1000059 \$1,241.00

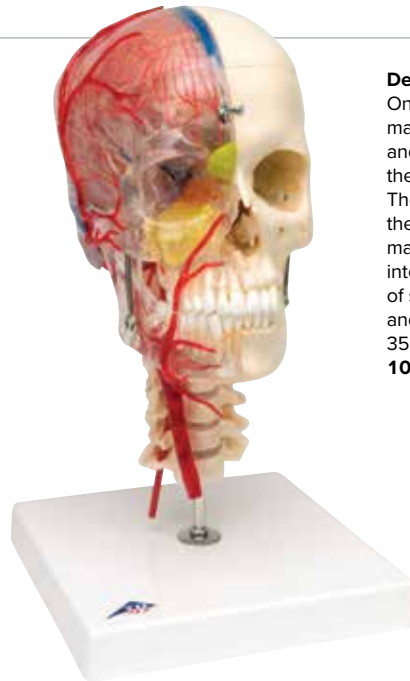

Deluxe Didactic Skull, 7-part

On the transparent half, the paranasal sinuses are marked in different colors as are the cranial sinuses and the neck and face arteries. One skull half visualizes the brain position and the course of the sinuses. The periodontal pockets can be viewed through the transparent jaw. The lower jaw demonstrates masticatory movements. The skull can be disassembled into both halves of the skullcap, the left half of the base of skull, the nasal septum, the complete mandible and a brain half.

35 x 18 x 18 cm; 1.0 kg
1000064 \$1,573.00



Combined Transparent/Bone Skull, 8-part

A unique way to study the internal and external anatomy of the skull. One half is transparent and the other is bony. It offers a topographic comparison of structures that are not visible in other skull models. The teeth can be taken out and the outer masticatory muscles are represented on the bony skull half. The skull can be disassembled into two halves.

16 x 14 x 21 cm; 0.54 kg
1000063 \$1,011.00



Human Bony Skull, 6-part

An outstanding skull for studies of the bony structure and complex anatomy of the human skull. This version shows a complete skull in median-sagittal section. It can be disassembled into two halves consisting of: 1) the calvarium and the base of the skull, and 2) the nasal septum and complete mandible. For a demonstration of masticatory motion, the mandible is mounted flexibly.

16 x 14 x 21 cm; 0.5 kg
1000062 \$801.00

Skull with Facial Muscles

Easily demonstrate causes of temporomandibular disorders and other dysfunctional disturbances of the masticatory muscles with this high quality skull model. It is anatomically precise and manufactured specifically to withstand wear and tear from educational use. The right half features the face and mastication muscles. They can easily be differentiated by color. Cranium and m. masseter are easily detachable to reveal the structures underneath. The left side shows hand-painted muscle origins and insertions to further clarify the structural interaction of muscles and skull bones. The jaw is movable and due to the flexible musculature the rudimentary chewing motion can be demonstrated. Made in Germany and cast from an original human skull, using our highest quality material.

18 x 18 x 25 cm; 1.08 kg
1020181 \$347.00





Skull with Cleft Jaw and Palate

This skull model depicts a male with a severe malformation of the left skull half with a cleft jaw and palate. The one-part skull has 29 teeth and is natural cast.

28 x 23 x 19.5 cm; 0.8 kg

1000067 \$419.00

You can add a brain (not included)

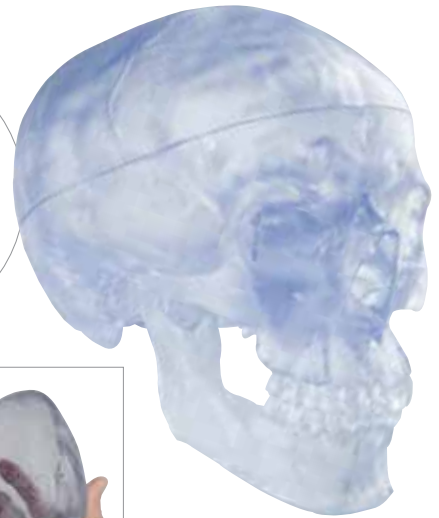

Magnetic connections for easy, hands-on demonstrations



Fetal Skull Model

Natural cast of a fetal head in the 30th week of pregnancy showing the characteristics of prenatal development. The fontanelles, which become bone over time, are clearly visible on the skull. Sutures will form along the bony plates helping fuse the skull as the individual ages. Delivered on stand.

18.5 x 14.5 x 14 cm; 0.2 kg

1000050 \$65.00

Fetal Skull Model, without stand (not shown)

14 x 9 x 9 cm; 0.15 kg

1000057 \$56.00

Transparent Classic Human Skull Model, 3-part

A great addition to any educational collection! Use this unique transparent replica of the human skull to study internal structures!

- High-quality original casts
- Skull is handmade of hard, unbreakable plastic
- Highly accurate representation of the fissures, foramina, processes, sutures
- Can be disassembled into Skull Cap, Base of Skull and Mandible
- A 5-part classic brain can be inserted into the skull. See page 40 for details.

20 x 13.5 x 15.5 cm; 0.6 kg

1020164 \$165.00

Glow in the Dark Skull Model *All anatomical details are not only true to life, but also glow in the dark!*

Great as a gift for those students or friends needing a flash of inspiration.

20 x 13.5 x 15.5 cm; 0.6 kg

1000050 \$155.00



Mini Human Skull Model, 3-part

It precisely depicts the anatomical structures of the human skull in a manner that is true to detail and can be disassembled into skullcap, base of skull and mandible.

10 x 8 x 8 cm; 0.1 kg

1000041 \$39.00

MUSCULATURE MODELS



A. Life-Size Male Muscle Figure, 37-part

This sophisticated model shows the deep and superficial musculature in great detail. Extraordinary accuracy makes this masterpiece a unique tool for instruction even in large lecture halls. Extra shipping charges may apply. 180 x 110 x 50 cm; 53 kg
1001235 \$8,835.00

The following parts can be removed for study:

- Skull cap
- 6-part brain
- Eyeball
- Breast/abdominal wall
- Both arms
- 2-part larynx
- 2-part lung
- 2-part heart
- Diaphragm
- 2-part stomach
- Kidney
- Liver with gall bladder
- Bladder half
- Whole intestine system
- 2-part penis
- 10 muscles



B. 3/4 Life-Size Dual-Sex Muscle Figure, 45-part

The finest teaching tool available! Standing over 4 1/2 feet tall, this 3/4 life-size human replica depicts deep and superficial musculature in addition to the body's major nerves, vessels, tissues and organs in exquisite detail. The internal organs are removable (45 pieces in all) to reveal the fundamental interrelationships of human morphology. Remove and view the details of 13 different muscles of the arms and legs and over 600 hand-numbered structures. This dual sex muscle figure version has interchangeable genital inserts and a female mammary gland. Hand-painted and mounted on a convenient roller base. Visit 3bscientific.com for all removable parts and product manual.

138 x 50 x 32 cm; 12.4 kg
1013881 \$7,995.00

3/4 Life-Size Female Muscle Figure, 23-part (not shown)

This Female Muscle Figure provides the same quality characteristics as the model B50 above but is delivered without internal organs, brain, and male genitalia providing for unobstructed study of the human musculature.

138 x 45 x 32 cm; 11.2 kg
1013882 \$7,437.00

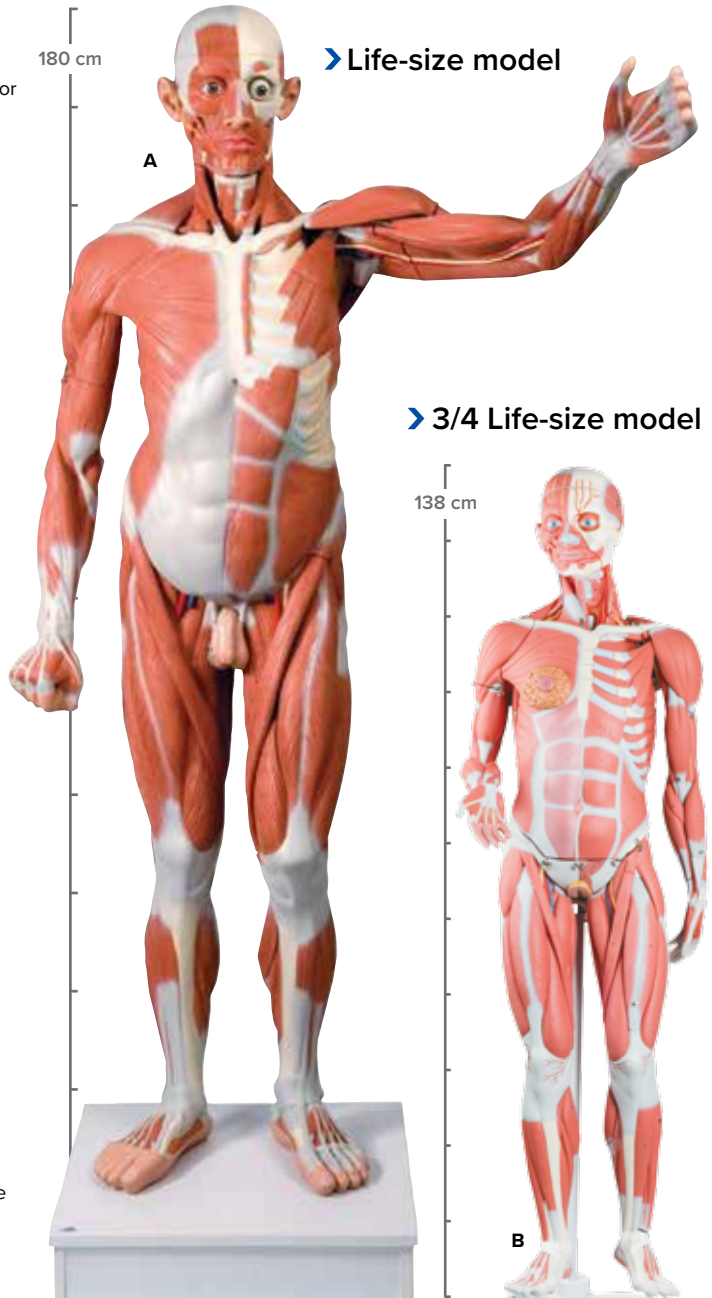

➤ Life-size model

➤ 3/4 Life-size model

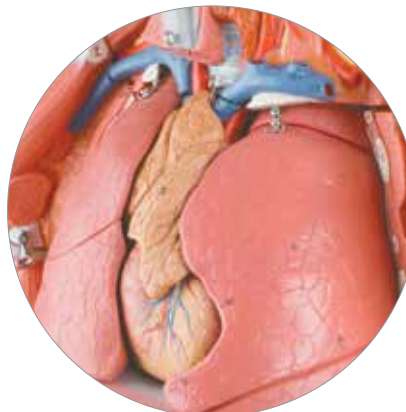

Removable organs

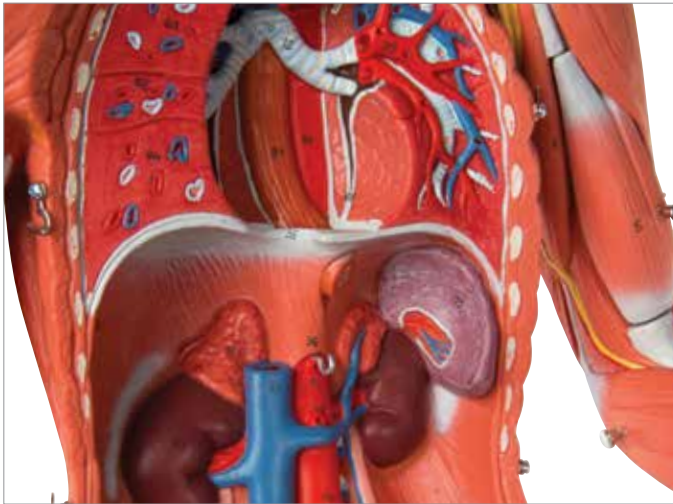

➤ **A space saving alternative with amazing detail at half life-size!**



1/2 Life-Size Complete Dual Sex Muscle Figure, 33-part

This convenient and complete human musculature model is the perfect choice for thorough **demonstrations of human musculature and internal organs** where space is a concern. Exquisitely **hand-detailed and complete with 33 removable parts**, this human muscular figure represents the **finest quality at an affordable price**. Painted by hand in realistic colors, this human anatomy model comes complete with stand and detailed multilingual product manual.

Includes the following removable parts:

- 5 arm/shoulder muscles
- 8 leg/hip muscles
- 2-part heart
- 2-part brain
- 2 lungs
- 2-part male and 2-part female genital inserts
- 2-part intestine system
- Detachable breast/belly covering and arms for detailed study
- Almost 400 hand-numbered structures identified in the manual

84 x 30 x 30 cm; 4.95 kg
1019231 \$3,603.00



1/2 Life-Size Complete Female Muscle Figure, 21-part (not shown)

Offering the same exceptional value as the dual sex version above, this version is delivered without internal organs, brain and male genitalia.

84 x 30 x 30 cm; 4.1 kg
1019232 \$3,268.00

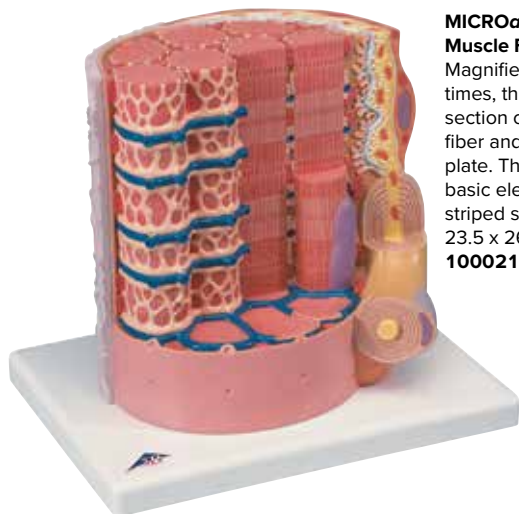

MICROanatomy™ Muscle Fiber

Magnified approximately 10,000 times, this model illustrates a section of a skeletal muscle fiber and its neuromuscular end plate. The muscle fiber is the basic element of the diagonally striped skeletal muscle.

23.5 x 26 x 18.5 cm; 11 kg
1000213 \$298.00

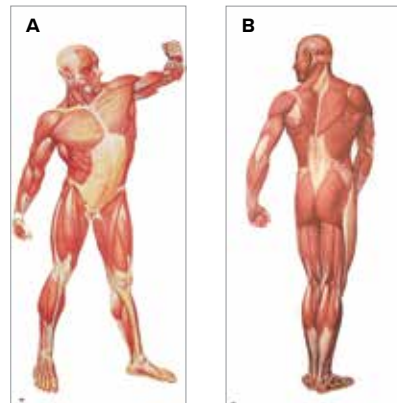

3B Scientific® Human Musculature Oversized Wall Charts

Printed on tear-resistant, waterproof paper with wooden rods so they are ready to hang. Accurately rendered scientific content.

84 x 200 cm

A. Front Side

V2003M

\$60.00 ea.

B. Back Side

1001153

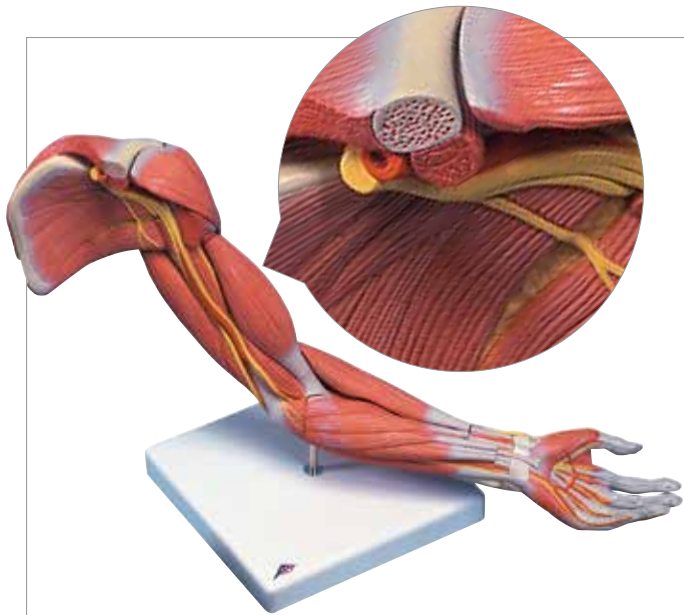

Deluxe Muscle Arm, 6-part

The following muscles can be detached in this life-size model:

- Deltoid muscles
- Biceps muscle of arm
- Triceps muscle of arm
- Long palmar muscle with radial flexor muscle of wrist
- Brachioradial muscle with radial extensor muscle of wrist

Supplied on base
41 x 48 x 48 cm; 3.0 kg
1000347 \$1,056.00



3/4 Life-Size Muscle Arm, 6-part

This 3/4 life-size muscled arm model illustrates both the superficial and deeper muscles, five of which are removable. Tendons, vessels, nerves and bone components of the left arm and shoulder are shown in great detail on this high quality muscle model. Over 70 numbered parts for easy identification, named in the accompanying product manual. Delivered on removable stand.

60 x 18 x 18 cm; 1.9 kg
1000015 \$562.00



► Each leg and arm muscle is supplied with removable stand!

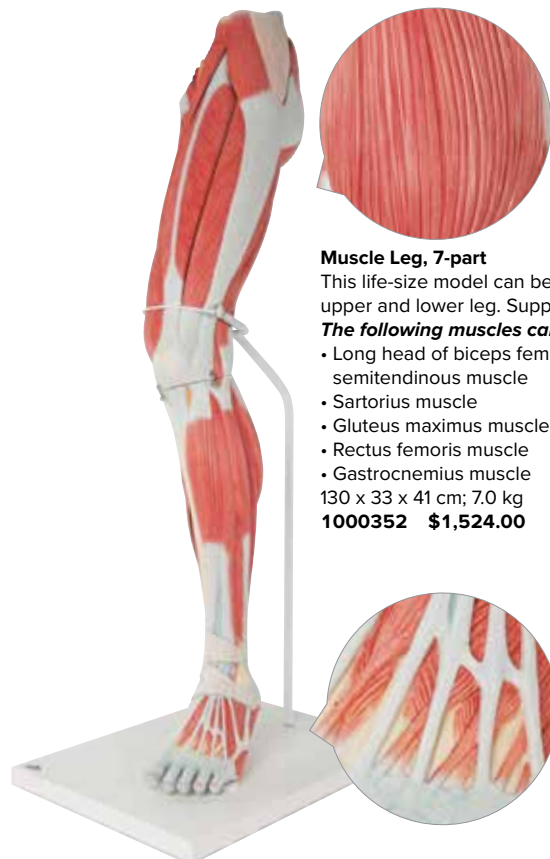

Muscle Leg, 7-part

This life-size model can be disassembled into upper and lower leg. Supplied on base.

The following muscles can be detached:

- Long head of biceps femoris with semitendinous muscle
- Sartorius muscle
- Gluteus maximus muscle
- Rectus femoris muscle
- Gastrocnemius muscle

130 x 33 x 41 cm; 7.0 kg
1000352 \$1,524.00

Life-Size Lower Muscle Leg with Detachable Knee, 3-part

Life-size replica of lower leg, ankle, and foot. On removable base for close up study.

Features of the lower muscular leg:

- Detachable knee cross section to expose the articular surfaces
- Detachable gastrocnemius muscle

58 cm; 2.6 kg
1000353 \$933.00



Muscle Leg, 9-part

Illustrating both the superficial and deeper muscles, eight of which are removable. Tendons, vessels, nerves and bone components of the left leg and foot are shown in great detail. Parts numbered. Delivered on removable stand.

77 x 26 x 26 cm; 4.0 kg
1000351 \$825.00



Life-Size Dual Sex Human Figure, 39-part

This life-size, dual sex model facilitates an understanding of human anatomy like no other human anatomy model in the world! One half exposes the musculature, while the other shows the skin for a more realistic effect that puts the human touch back in. The figure can be disassembled easily to show the inner structures and organs in amazing detail.

Altogether, 39 component parts can be removed:

- 2-part head
- Brain half
- M. Sterno cleidomastoid
- M. Deltoideus
- M. Biceps brachii
- M. Triceps brachii
- M. Palmaris longus with m. Flexor carpi radialis
- M. Brachioradialis with m. Extensor carpi radialis
- Skin of the left arm
- Muscled leg, upper part
- Muscled leg, lower part
- Skin of the left le
- Abdominal cover
- Mammary gland
- 2 removable lungs
- 2-part removable heart
- Removable Liver
- 2-part removable stomach
- Removable kidney half
- 4-part removable intestines
- 3-part female genital insert with embryo
- 4-part male genital
- M. Satorius
- M. Gluteus maximus
- M. Rectus femoris
- M. Gastrocnemius
- M. Biceps femoris cap. L. with m. semitendinosus

Comes with wooden roller base and includes free anatomy software!

Caucasian features.

174 cm; 40.7 kg

1000209 \$8,601.00



39 extremely detailed components, plus free software!

On wheels, easy to move

> Life-size model



Life-Size Dual Sex Asian Human Figure, 39-part

Same features as 1000209 above, but with Asian features.

174 cm; 40.7 kg

1000208 \$8,601.00



> Fits on your desk



1/3 Life-Size Muscle Figure, 2-part

The 1/3 life-size mini muscle figure shows the superficial musculature. It is accurately reproduced and detailed in life-like. The chest plate is removable from the muscular figure to reveal the internal organs and the right side contains a female mammary gland. 125 hand-numbered and identified structures of the human anatomy on base.

57 x 25 x 18 cm; 2.1 kg

1000212 \$674.00

TORSO MODELS

› Manufactured to precise anatomical detail!

Life-Size Muscle Torso, 27-part

This life-size muscle torso shows the **deep and superficial muscles in great anatomical detail**. Its anatomical precision and realism make it an outstanding tool for **demonstration even in large lecture halls**.

For detailed study and to reveal inner structures, the following pieces can be removed easily:

- Skull cap
- 6-part brain
- Eyeball with optic nerve
- Chest/abdominal wall
- 2-part larynx
- 2 lungs
- 2-part heart
- Diaphragm
- 2-part stomach
- Liver with gallbladder
- Complete intestinal tract with appendix
- Front half of kidney
- Half urinary bladder
- 4 muscles

Delivered on sturdy base.

95 x 60 x 35 cm; 14 kg

1001236 \$5,640.00

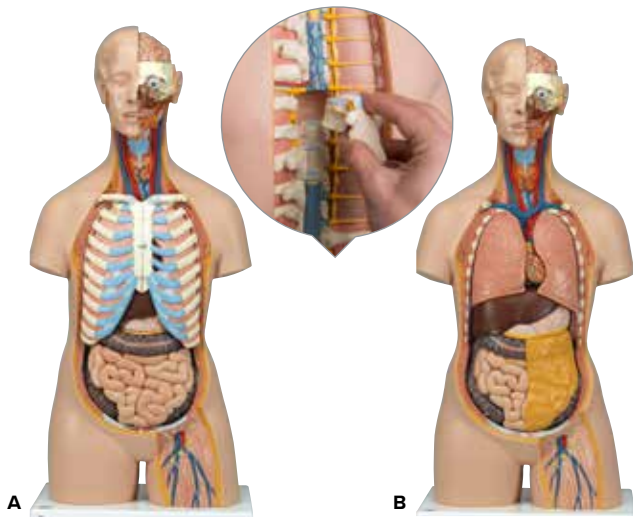

A. Classic Unisex Torso with Open Back, 21-part

This torso is based on the B11 version for students and is equipped with an open neck and back section going from the cerebellum to the coccyx. Vertebrae, intervertebral discs, spinal cord, spinal nerves, vertebral arteries, and many other features are represented in detail.

This version contains the following features in addition to 1000188:

- 7th Thoracic vertebra removable
- 6-part Head
- 2-part Stomach

87 x 38 x 25 cm; 6.5 kg

1000192 \$1,385.00

B. Classic Unisex Torso with Opened Neck and Back, 18-part

Based on our B13 torso, this model is characterized by its open neck and back section reaching from the cerebellum to the coccyx. Vertebrae, intervertebral discs, spinal cord, spinal nerves, vertebral arteries, and many other features are represented in detail and can be studied closely.

This version contains the following features in addition to B13:

- 7th Thoracic vertebra removable
- 6-part Head

87 x 38 x 25 cm; 5.8 kg

1000193 \$776.00

Classic Unisex Torso, 16-part

This torso is especially popular among students.

It shows the human anatomy in great detail and contains the following removable parts:

- 3-part head
- 2 Lungs with sternum and rib attachments
- 2-part heart
- Stomach
- Liver with gall bladder
- 4-part Intestinal tract
- Front half of kidney
- Front half of urinary bladder

87 x 38 x 25 cm; 6.8 kg

1000188 \$685.00

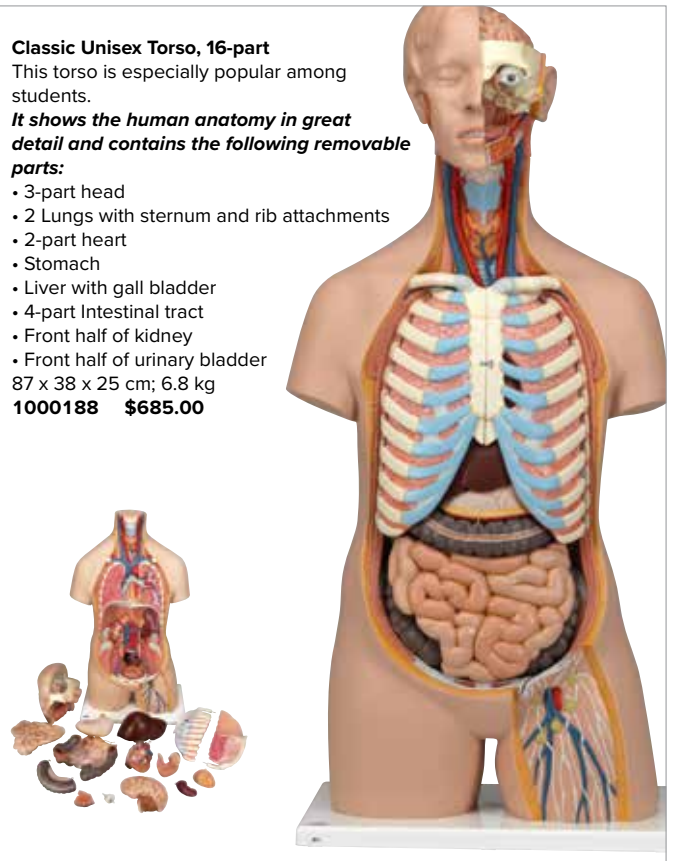

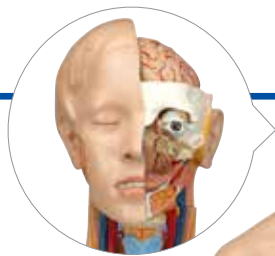

3-part head with removable brain half and eye.

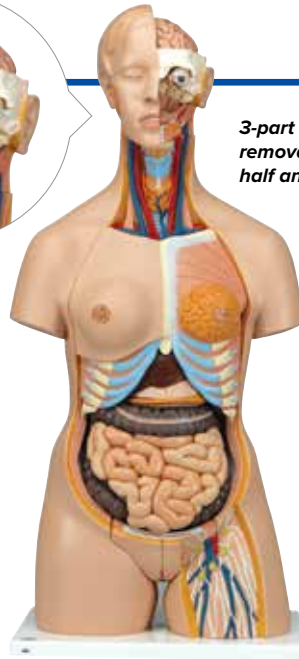

Opened back for detailed study

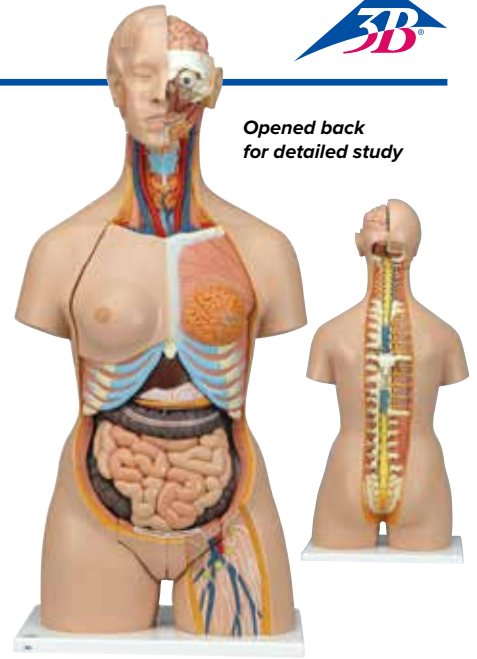

Signature Dual-Sex Muscle Torso, 31-part

This unique torso depicts both the superficial and deep muscles. The two main muscles, the deltoid and gluteus maximus can even be removed for closer studies. You can also study the vertebrae, the spinal cord, spinal nerves and vertebral arteries, exchange the male and female genital inserts, discover the internal structures of the brain and much more. Supplied with the 3B Scientific® Guide to the Human Torso.
87.12 x 38.1 x 24.9 cm; 8.5 Kg
1000203 \$2,805.00

Signature Dual-Sex Torso, 24-part

Need even more features? Comes with the 3B Scientific® Guide to the Human Torso. This advanced version features all removable parts found in our popular torso 1000197 plus the following upgrades:
• 3-part Head
• 2-part Stomach
• 4-part Intestine system
87.12 x 38.1 x 24.9 cm; 7.5 kg
1000196 \$1,209.00

Signature Dual-Sex Torso with Opened Back, 28-part

This torso has it all! Removable male and female genital inserts, opened neck and back section to study vertebrae, intervertebral discs, spinal cord, spinal nerves, vertebral arteries etc., a deluxe head with 4-part brain and much more! A detailed torso for advanced demonstrations. See 3bscientific.com for all removable parts.
87.12 x 38.1 x 24.9 cm; 7.6 kg
1000200 \$1,231.00

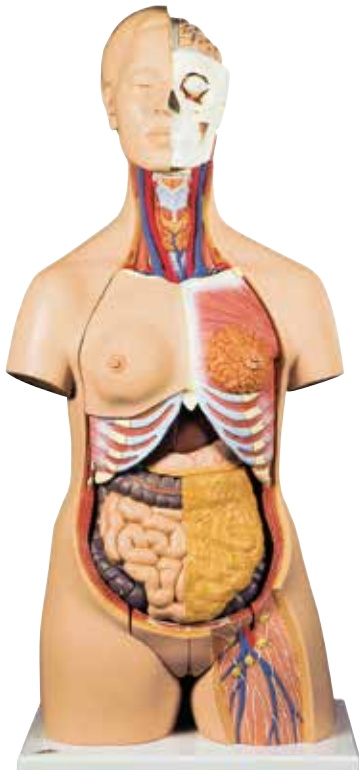

Dual Sex Torso, 20-part

Detailed demonstration model for human anatomy focussing on inner organs. All parts are easy to remove and the torso can be switched from male to female with no problems!

This life-size, high quality human torso contains these removable parts and organs:

- 2-part head
- Female chest wall
- 2 lungs
- 2-part heart
- Stomach
- Liver with gallbladder
- 2-part intestinal tract
- Front half of kidney
- 4-part male genital insert
- 3-part female genital insert with fetus

All organs are hand painted for a quality product with realistic colors. Delivered on sturdy base and complete with the 3B Scientific® Torso Guide.

Light skin.
87 x 38 x 25 cm; 7.3 kg
1000197 \$1,100.00



Deluxe Asian Dual Sex Torso, 18-part

Dual-sex torso with removable internal organs, made high quality durable plastic.
1000199 \$924.00

Dual Sex Torso with Muscle Arm, 33-part

A worldwide unique feature of this life-size torso is the removable 6-part muscle arm. This top of the line model fully represents the anatomy of the complete human upper body. Its great detail makes it especially suitable for the high standards of medical education. The right half shows the skin, the left half the superficial and deeper muscles with nerves, vessels and bony structures. The versatility of this aesthetically designed model is rounded off by the exact representation of the internal organs.

The following parts can easily be removed for closer study:

- 2-part head
 - Brain half
 - Sternocleidomastoideus muscle
 - 6-part muscle arm (removable Muscles: deltoid, biceps brachii, triceps brachii, palmaris longus with flexor carpi radialis, brachioradialis with extensor carpi radialis)
 - Upper leg stump
 - Chest/abdominal wall with detachable mammary gland
 - Torso body
 - 2 lungs
 - 2-part heart
 - Liver with gallbladder
 - 2-part stomach
 - Kidney half
 - 4-part intestinal tract
 - 3-part female genital insert with fetus
 - 4-part male genital insert
- 90 cm; 22.8 kg
1000205 \$5,494.00

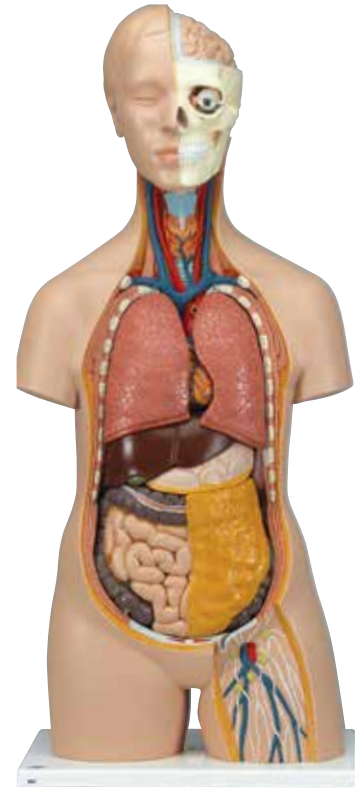
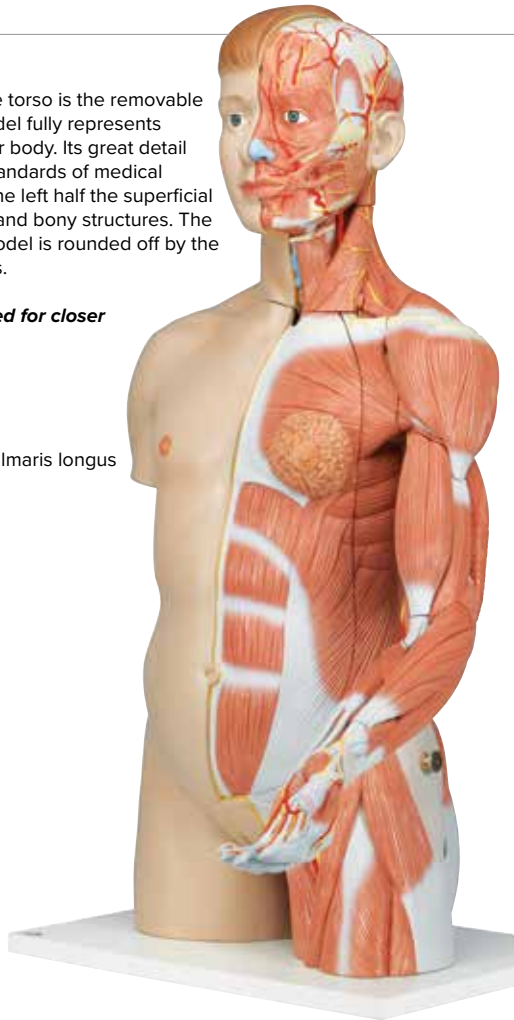

Classic Unisex Torso, 12-part

The following components of this torso are removable:

- 2-part Head
 - 2-part Removable heart
 - 2 lungs
 - Stomach
 - Liver with gall bladder
 - 2-part Intestinal tract
 - Front half of kidney
- 87 x 38 x 25 cm; 4,6 kg
1000186 \$577.00



Asian Dual Sex Torso with muscular arm, 33-part

This life-size human torso models comes with all features of the 1000205 Dual Sex Torso with Muscle Arm (see right), but with Asian features.
 90 cm; 22.8 kg
1000204 \$5,494.00

Classic Gender Neutral Torso, 14-part

This 14-part anatomically correct human torso model is an educational tool of true quality. The gender neutral torso is hand-painted in true to life detail and made of high-quality plastic for hands-on education. It is mounted on a sturdy base so students can safely disassemble it.

The following parts can be removed:

- 3-part head
 - 2 lungs
 - 2-part heart
 - Stomach
 - Liver with gallbladder
 - 2-part intestinal tract
 - Front half of kidney
 - Front half of urinary bladder
- Includes 3B Scientific® Torso Guide.
 Light skin.
 87 x 38 x 25 cm; 5,9 kg
1000190 \$665.00

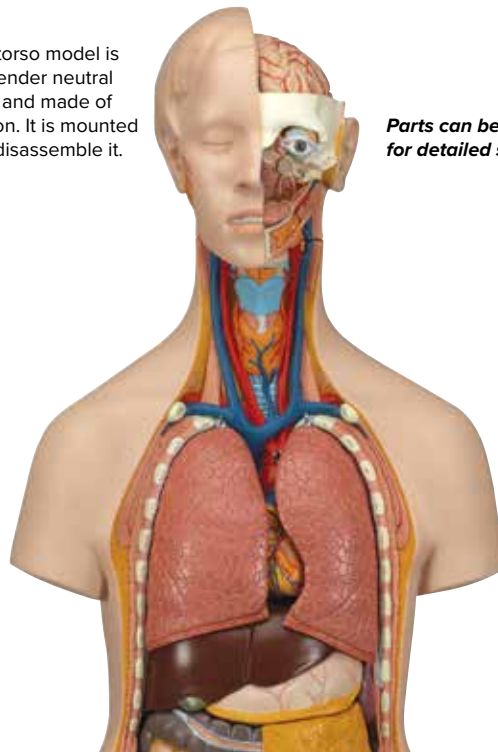

Parts can be removed easily for detailed study



➤ You will find a learning card for every disc inside the product manual.

MRI Torso, 15 Transverse Sections

This unique MRI torso is horizontally sectioned into 15 slices, giving a distinctive view of human anatomy. The topographical relationships of the torso are represented as colored reliefs on the individual sectional planes. For a closer study of the internal anatomy of the torso, each disc can be shifted horizontally and rotated around its sagittal axis. Each disc within the MRI torso can be individually removed. The results are a brand new understanding of human anatomy that is both interesting and engaging for students. This MRI torso is a great addition to any medical classroom!

130 x 40 x 35 cm; 19 kg
1001237 \$5,739.00

Each disc can be shifted horizontally for closer study from any angle

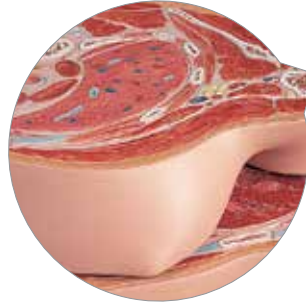

Heavy Duty Protective Cover for Torsos

Protect your investment with this heavy duty protective cover for your torso models. Suitable for all full-size torsos. Zippered with reinforced easy-carry handle. Black.

1020762 \$43.75



➤ Looking for a smaller alternative for your desk?

Mini Torso, 12-part

This mini masterpiece is half life-size so even small hands can quickly disassemble the torso. All parts are numbered and identified on the included product manual.

Removable parts include:

- 2 Head halves
- Brain half
- 2 Lungs
- 2-part Heart
- Liver with gall bladder
- Stomach
- 2-part Intestinal tract

54 x 24 x 18 cm; 2.0 kg
1000195 \$193.00

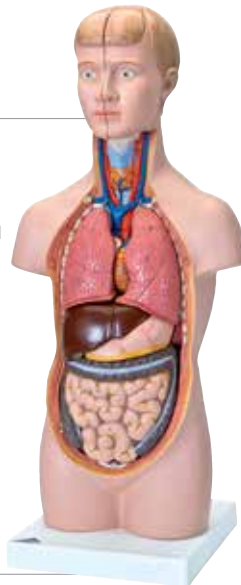

Dual Sex Torso, Dark Skin, 24-part

This life-size, deluxe human torso model comes with all features of the Dual Sex Torso, 24-part (B30) but with dark skin.

87 x 38 x 25 cm; 7.5 kg
1000202 \$1,209.00

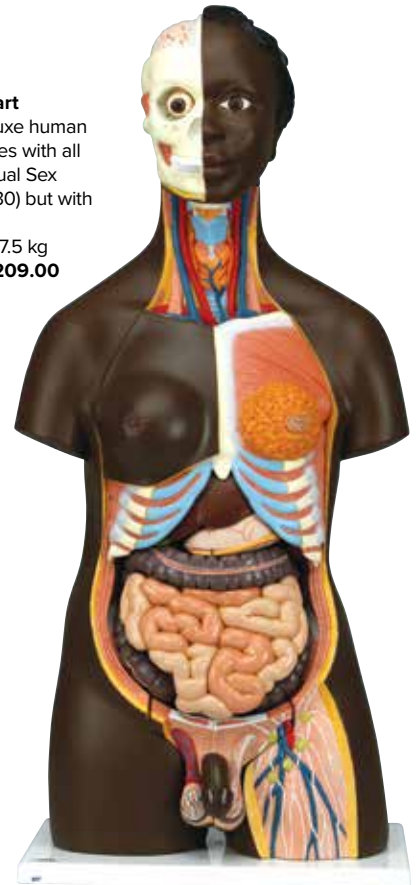

3B Scientific® Torso Guide (not shown)

Already included with most torso model purchases.

- Brilliantly colored pictures of each part of the torso, explaining even the smallest structures
- Includes teaching tips to create even more interesting lessons
- Complete in 7 different languages (Latin, English, German, Spanish, Portuguese, French, Japanese)
- Includes CD-ROM in pdf-format to assist in creating tests or preparing lessons

1000183 \$67.00

3B Scientific® Torso-Classroom Set (not shown)

Includes 33 brilliant overhead-foils with colored pictures of each part of the torso.

1000184 \$145.00

SKIN MODELS



Skin Block Model, 70 Times Full-Size

This distinctive model shows a section of human skin in three dimensional form. Individual skin layers are differentiated and important structures such as hair, sebaceous and sweat glands, receptors, nerves, erector pili muscles and vessels are shown in great detail. Mounted on baseboard.

44 x 24 x 23 cm; 3.6 kg

1000291 \$353.00



Skin, Hair, and Nail Microscopic Structures

This model shows the microscopic structure of the skin in great detail. Both hairless and hairy skin structure are shown as well as the different cell layers of the skin, embedded sweat glands, touch receptors, blood vessels, nerves, erector pili muscle, and a hair follicle. In addition to these details, a section of nail is shown on the base depicting the nail plate, bed, and root. Completing the skin model is a representation of a hair root with all of its cellular layers.

10 x 12.5 x 14 cm; 0.35 kg

1000292 \$80.00

> 3 Models in 1!

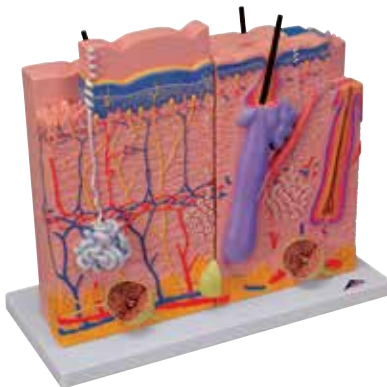

Skin Model, 3-part

All three models are located on a common base, can be removed individually, and can be attached together via magnets to show the interrelationships. Distinctions within the skin are illustrated with regard to the positions on the human body such as the palm of the hand, back of the hand and scalp. See online for full description.

34 x 39 x 15.5 cm; 2.05 kg

1000294 \$270.00

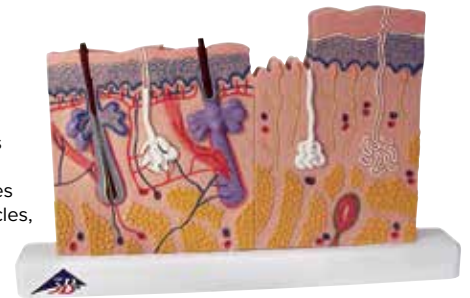

Skin Section, 40 Times Life-Size

The two halves of this relief model show the three layers of hairy and hairless skin in order to make the differences clear. Detailed with hair follicles, sebaceous glands, sweat glands, receptor, nerves, erector pili muscles and vessels. Delivered on base.

24 x 15 x 3.5 cm; 0.2 kg

1000290 \$93.00



Skin Section, 70 Times Full-Size

This relief model shows a section through the three layers of the hair-covered skin of the head.

Delivered on base it shows:

- Sweat glands
- Vessels
- Receptors
- Nerves
- Representation of hair follicles with sebaceous glands

26 x 33 x 5 cm; 1.1 kg

1000289 \$115.00

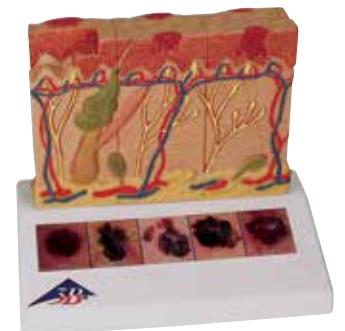

Skin Cancer Model

This 3B Scientific® Skin Pathology model shows healthy skin and 5 different stages of malignant melanoma on the front and back, enlarged 8 times:

- Healthy
- Malignant cells are found at the surface, within the epidermis
- Malignant cells fill the epidermis, a few invade the papillary layer
- Malignant cells fill the papillary layer
- Malignant cells invade the reticular layer
- Malignant cells have reached the subcutaneous fatty tissue, satellite cells approach a vein

14 x 10 x 11.5 cm; 0.2 kg

1000293 \$77.00

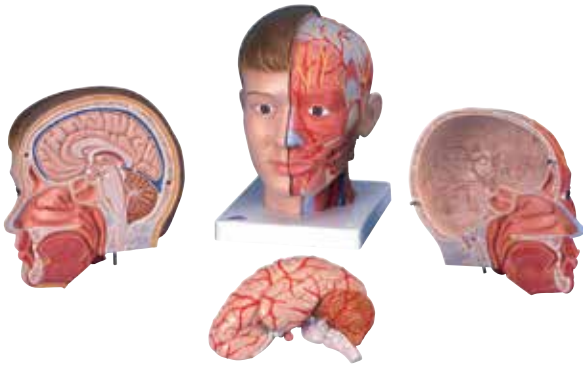

Deluxe Head with Neck, 4-part

The left half of this life-size midsagittal section shows the muscles with nerves, vessels, and bony structures. It also contains a removable brain half. The head is mounted on a detachable neck, which is sectioned both horizontally and diagonally. Supplied on baseboard.

28 x 19 x 23 cm; 2.2 kg
1000216 \$1,423.00

Median Section of the Head

This relief model shows all relevant structures of the human head in great detail and is also delivered on a baseboard.

26 x 33 x 5 cm; 1.0 kg
1000219 \$140.00



Half Head with Musculature

Representation of the outer, superficial, and internal (median section) structures of head and neck. Delivered on removable stand.

22 x 18 x 46 cm; 1.1 kg
1000221 \$433.00



Head Musculature

Representation of the superficial musculature of head and neck showing:

- Parotid gland
- Submandibular gland
- Deep musculature
- Lower jaw partially exposed

24 x 18 x 24 cm; 1.2 kg
1001239 \$276.00



Head Musculature with Blood Vessels

All the features of VB127, plus a display of the blood vessels.

24 x 18 x 24 cm; 1.2 kg
1001240 \$399.00



Head Musculature with Nerves

All the features of VB127, with an additional display of nerves.

24 x 18 x 24 cm; 1.2 kg
1008543 \$362.00

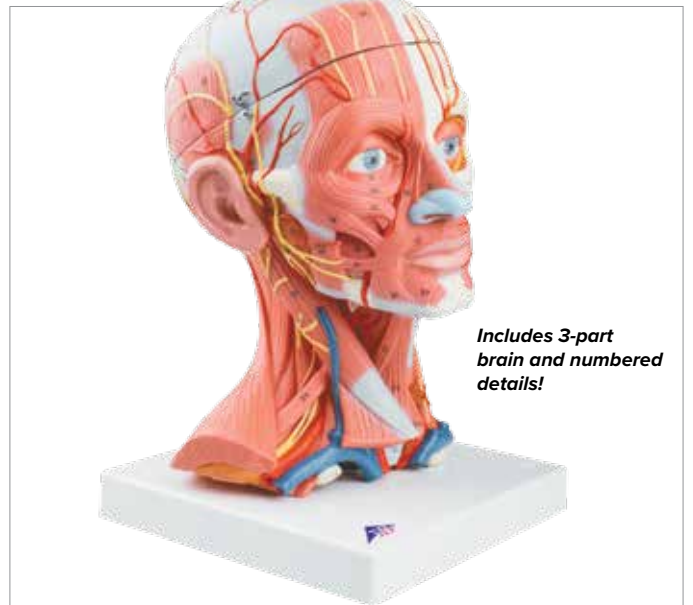

Includes 3-part brain and numbered details!

Head and Neck Musculature, 5-part

The model represents the superficial musculature and deep muscles of the head. The nerves and vessels of the head are also depicted. The head is dissectible into skull cap and 3-part brain. Delivered on a removable baseboard.

36 x 18 x 18 cm; 1.8 kg
1000214 \$1,126.00

➤ This brain model fits all 3B Scientific® classic skulls so you can upgrade whenever you like!



Classic Brain, 5-part

This midsagittally sectioned model is an original anatomic cast of a real human brain. Now with magnetic closures!

The components of its left half are:

- Frontal and parietal lobe
- Temporal and occipital lobe
- Encephalic trunk
- Cerebellum

13 x 14 x 17.5 cm; 0.49 kg

1000226 \$226.00



Deluxe Brain, 8-part

A very detailed medially divided model of the human brain. On a removable base.

Both halves can be disassembled into:

- Frontal with parietal lobes
- Temporal with occipital lobes
- Half of brain stem
- Half of cerebellum

14 x 16 x 14 cm; 0.85 kg

1000225 \$265.00



Brain, 4-part

This brain is medially divided. All structures are hand-painted, numbered, and identified in an accompanying product manual. On removable base.

The right half can be disassembled into:

- Frontal with parietal lobes
- Brain stem with temporal and occipital lobes
- Half of cerebellum

14 x 14 x 17.5 cm; 0.9 kg

1000224 \$225.00



Deluxe Brain with Arteries, 10-part

This deluxe brain comes with an opened head to allow detailed study of the brain's position in the skull. The head is horizontally divided above the skull base. The brain is divided medially, with a removable basilar artery. Both halves can be divided into frontal parietal lobes, temporal with occipital lobes, and half of cerebellum. On base.

15 x 15 x 23 cm; 1.6 kg

1017869 \$512.00



Deluxe Head Model, 6-part

Our most detailed head model! This life-size 6-part head is mounted on a base and features a removable 4-part brain half with arteries. The eyeball with optic nerve are also removable. One side exposes the nose, mouth cavity, pharynx, occiput, and skull base.

19 x 23 x 22 cm; 1.33 kg

1000217 \$512.00

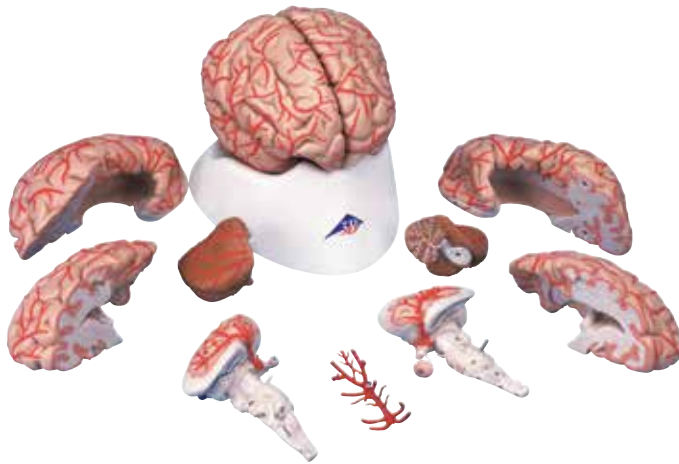

Deluxe Brain with Arteries, 9-part

This medially divided deluxe brain model shows the brain arteries as well as the detachable basilar artery. On a removable base.

Both halves can be disassembled into:

- Frontal with parietal lobes
- Half of brain stem
- Temporal with occipital lobes
- Half of cerebellum

15 x 14 x 16 cm; 0.84 kg

1017868 \$416.00



Brain Ventricle

This life-size model shows both lateral ventricles, the 3rd and 4th ventricle, and the aquaeductus cerebri (sylvius). On stand.

14 x 11 x 14 cm; 0.32 kg

1001262 \$164.00



Human Brain Chart

50 x 67 cm

1001584 \$21.00

➤ Did you know that 3B Scientific is represented in more than 100 countries worldwide. Learn more about us at 3bscientific.com!



Neuro-Anatomical Brain, 8-part

This deluxe brain is medially divided. On the right half you will find a colored, systematic grouping and representation of the cerebral lobe. Delivered on removable base.

14 x 14 x 17.5 cm; 0.95 kg

The left half shows:

- Pre- and post-central region
- Broca and Wernicke areas
- Heschl's gyrus
- Brain nerves
- Ventricles

1000228 \$428.00

Both halves can be

disassembled into:

- Frontal with parietal lobes
- Temporal with occipital lobes
- Half of brain stem
- Half of cerebellum

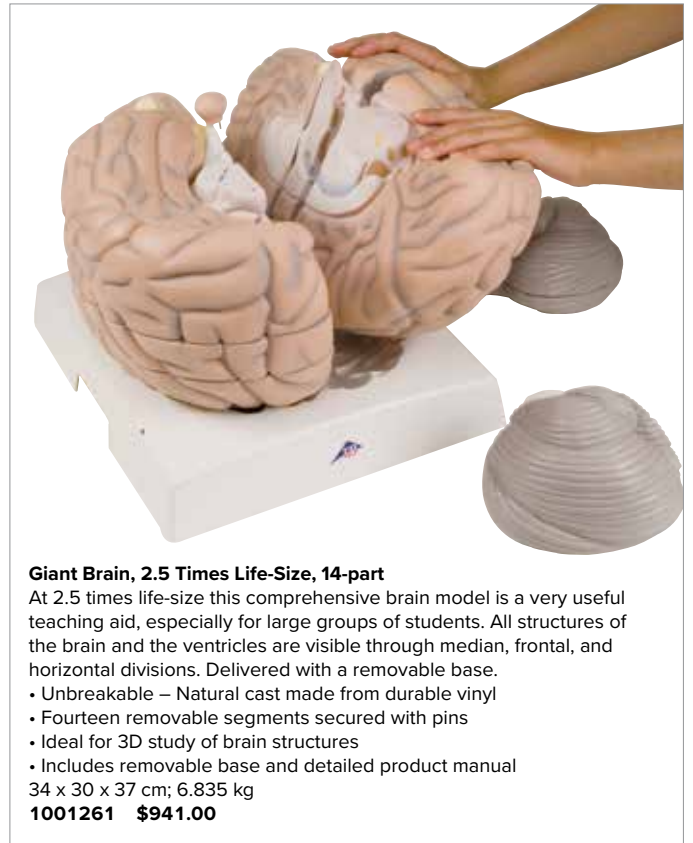

Giant Brain, 2.5 Times Life-Size, 14-part

At 2.5 times life-size this comprehensive brain model is a very useful teaching aid, especially for large groups of students. All structures of the brain and the ventricles are visible through median, frontal, and horizontal divisions. Delivered with a removable base.

- Unbreakable – Natural cast made from durable vinyl
- Fourteen removable segments secured with pins
- Ideal for 3D study of brain structures
- Includes removable base and detailed product manual

34 x 30 x 37 cm; 6.835 kg
1001261 \$941.00

> Double-sided brain sections!



Brain Section

An enlarged and very detailed section through the right half of the brain, including a portion of the skull. The pia mater has been removed. This model is double sided and finely colored. One surface is on the median line, including a section of the falx cerebri. A sagittal cut on the reverse side exposes the lateral ventricle. There are 49 references on the model, identified in English on an accompanying product manual. Mounted on a stand. 25 x 18 x 12 cm; 0.9 kg

1005113 \$390.00



Rat Brain Comparative Anatomy

Enlarged roughly six times, and medially sectioned, the rat brain model can be disassembled into two halves. The right half of the color-coded model shows the structures of the cerebrum, cerebellum, and brain stem. The left half is largely transparent with a view of the left lateral ventricle and hippocampus in the median section. For comparison, a natural cast of a rat brain and a didactic, small-scale illustration of a human brain in median section are shown on the base. Each has the same color coding used for the various regions. 14 x 10 x 16 cm; 0.24 kg

1000230 \$243.00

Physiology of Nerves

This five model series from 3B Scientific® is unique in the world. Interchangeable sections can be assembled to illustrate the features of typical neurons found in vertebrates. All sections depict the neural components in vivid colors and attach magnetically to the illustrated base.

68 x 51 x 10 cm; 4.2 kg

1000232 \$789.00

The set contains the following sections, which are also available individually:

- Neuron Cell Body
- Myelin Sheaths of the CNS
- Schwann Cells of the PNS
- Motor End Plate
- Synapse



Nervous System

An excellent model to study the structure of the human nervous system. 3-D relief model shows schematic representation of the central and peripheral nervous system.

80 x 33 x 6 cm; 3.5 kg

1000231 \$420.00



Median and Frontal Section of the Head

The perfect model to learn structure location. Two relief models on baseboard showing all relevant structures of the human head in great detail.

41 x 31 x 5 cm; 1.1 kg

1000220 \$212.00

Giant Functional Center Brain, 4-part

This popular brain model reproduces the brain of a right-handed person. It employs contrasting colors and hand-lettered captions to identify motor and sensory functional centers. In addition to focusing on the intellectual role of the dominant left brain, and the creative role of the right, the model highlights the emotional, sexual, memory, and learning functions of the limbic system. Sensory regions and centers receptive to 20 specific body regions are distinguished, as are the motor centers controlling 19 body regions. More than 120 hand-numbered features are identified in the corresponding key.

On base. 20 x 20 x 25 cm; 2.4 kg

1005555 \$520.95

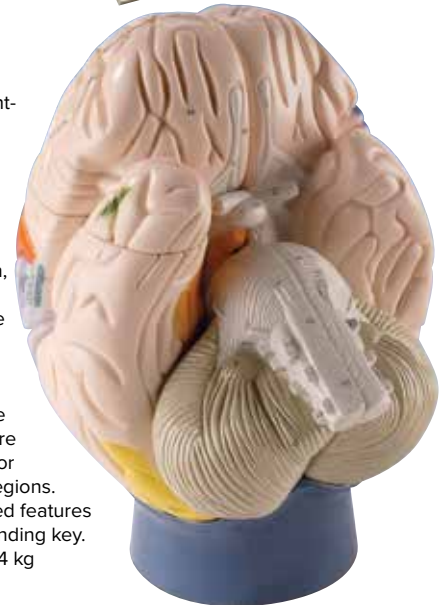

> Magnified over 2,500 times!

Motor Neuron Diorama

Magnified over 2,500 times. This color-coded, three-dimensional reproduction shows a motor nerve cell situated within a milieu of interacting neurons and a skeletal muscle fiber. The membranous envelope is cut away from the neuron to expose the cytological ultrastructure, organelles, and inclusions within the cell body. A section of the axon lifts off to let you view the tightly wound layers of the enveloping myelin sheath and neurolemma, as well as the Schwann cell which formed them. Via a cutaway view, you can observe synaptic vesicles, carrying neurotransmitters, about to stimulate the muscle fiber to action. Mounted on a wooden base. 43 x 20 x 28 cm; 3 kg

1005553 \$699.95



EYE MODELS



MICROanatomy™ Eye

The model illustrates the microscopic structure of the retina with choroid and sclera. The left, block-like, layered side of the model shows the complete structure of the retina including the supplying vascular layer and parts of the sclera from a lighted microscopic view. The right part of the model, a sectional enlargement, shows the microscopic structure of the photoreceptors and the cells of the pigmented layer.

25 x 23 x 18.5 cm; 1.11 kg

1000260 \$349.00



Classic Eye, 3 times Full-Size, 6-part

This model dissects into the following parts:

- Both halves of sclera with cornea and eye muscle attachments
- Both halves of choroid with iris and retina
- Lens
- Vitreous humour

9 x 9 x 15 cm; 0.136 kg

1000259 \$116.00

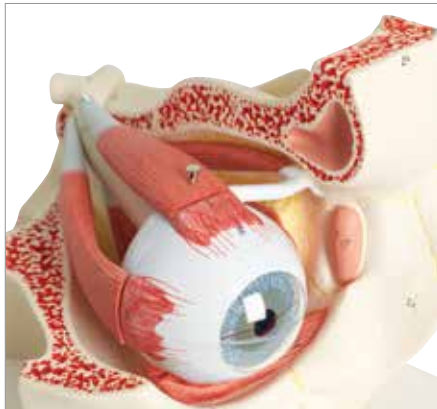

Classic Eye in Orbit, 3 times Full-Size, 7-part

Similar to item F15, this model additionally shows the optic nerve in its natural position in the bony orbit of the eye (floor and medial wall). On square base.

18 x 26 x 19 cm; 1.35 kg

1000258 \$310.00

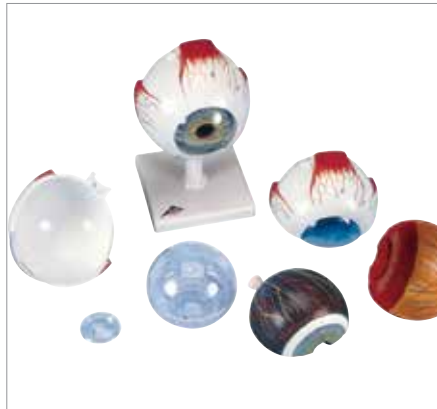

Giant Eye, 5 Times Full-Size, 6-part

An excellent model for teaching due to its enhanced size. The same removable parts as the F15. On square base.

13 x 14 x 21 cm; 0.74 kg

1000255 \$171.00



Giant Eye with Eyelid and Lachrymal System, 5 Times Full-Size, 8-part

All of the features of F15 plus the eyelid, lachrymal system, on a bony orbit. On square base.

20 x 18 x 21 cm; 1.174 kg

1000257 \$383.00

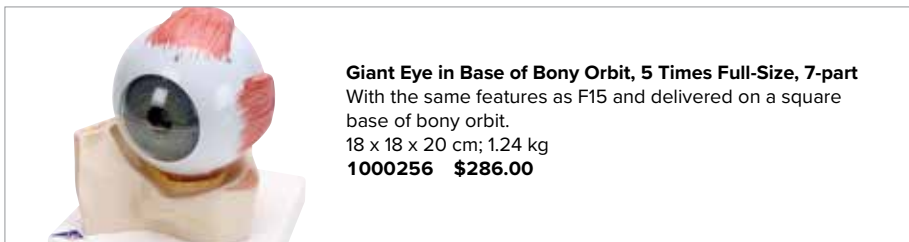

Giant Eye in Base of Bony Orbit, 5 Times Full-Size, 7-part

With the same features as F15 and delivered on a square base of bony orbit.

18 x 18 x 20 cm; 1.24 kg

1000256 \$286.00

► Retina and lens can be switched easily

Pathological Eye, 5 times Life-Size

The easy to use switchable and didactically simplified representations of the retina and lens make it possible to clearly explain the typical changes that occur in a healthy eye due to the following diseases:

- Subcapsular cataract
- Cortical cataract
- Nuclear cataract
- Diabetic retinopathy
- Hypertensive retinopathy
- Papillary changes of glaucoma
- Age-related macular degeneration
- Papilloedema
- Central retinal arterial occlusion
- Central retinal venous occlusion
- Rhegmatogenous retinal detachment

26 x 26 x 21 cm; 0.73 kg

1017230 \$330.00

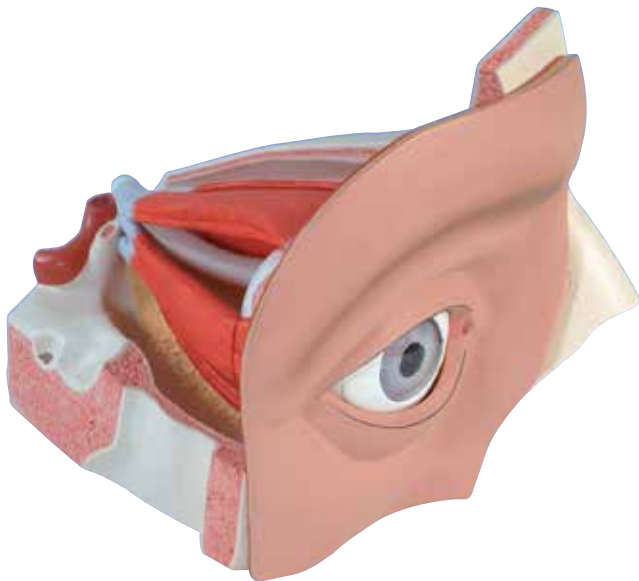

Eye, 5 times Full-Size, 12-part

- Both halves of the sclera
- Optic nerve
- M. rectus superior
- M. rectus lateralis
- Cornea half
- Lens
- Lachrymal system
- Vitreous humour
- Tear gland associated structures

33 x 30 x 38 cm; 4.382 kg

1001264 \$823.00

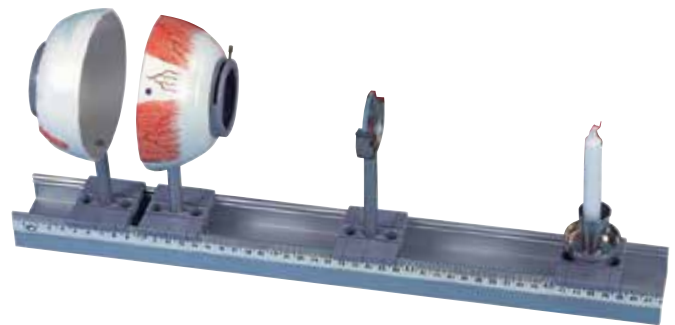

Physical Eye Model

Use to demonstrate the optical functions of the eye, e.g. representation of an object on the retina, accommodation, short-sightedness and far-sightedness.

- Half eyeball with adjustable iris diaphragm, lens holder and 2 convex lenses ($f = 65 \text{ mm}$ and 80 mm), on a rod
- Half eyeball with retina (transparent screen), on a rod
- Lens holder with one concave and one convex corrective lens, on a rod
- Candle holder with 2 candles, on a rod
- Aluminium rail, 50 cm long, with 4 clamp slides
- Includes case

49 x 5.5 x 18 cm; 2 kg

1003806 \$1,157.00

EAR, NOSE, & THROAT MODELS



Giant Ear, 5 Times Full-Size, 3-part

This version is a whopping 5 times life-size for easy viewing from anywhere in the classroom! Representation of outer, middle, and inner ear. Removable auditory ossicles, labyrinth with cochlea, and vestibulocochlear nerve. Delivered on base.

25 x 41 x 25 cm; 3.0 kg

1008553 \$374.00

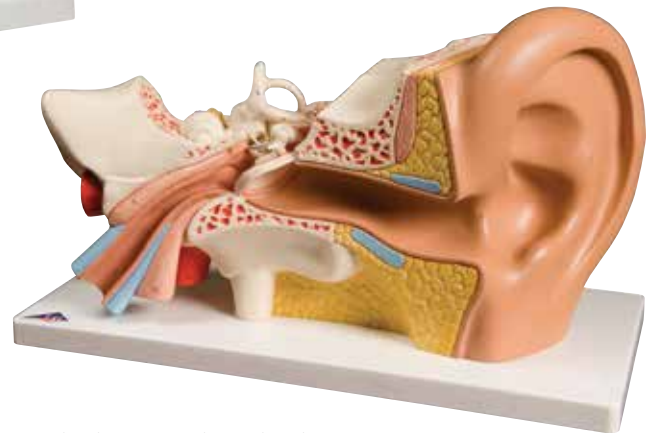

Classic Giant Ear, 3 Times Life-Size, 4-part

At approximately 3 times life-size, the model has representations of the outer, middle, and inner ear. Removable eardrum with hammer, anvil, and stirrup, as well as 2-part labyrinth with cochlea, and auditory/ balance nerve. On base.

34 x 16 x 19 cm; 1.25 kg

1000250 \$147.00

Giant Ear Advanced Version, 3 Times Life-Size, 6-part

The same features as E10, with the addition of two removable bone sections to close the middle and inner ear.

34 x 16 x 19 cm; 1.55 kg

1000251 \$187.00

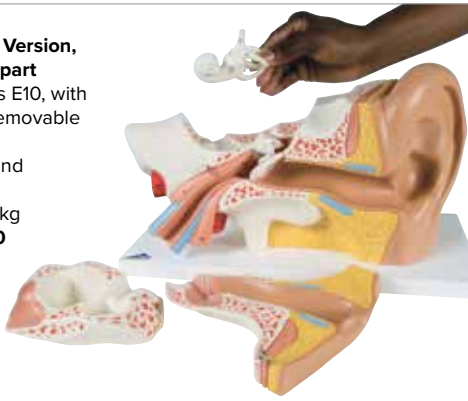

Desktop Ear Model, 1.5 Times Life-Size

Specifically designed for those on a budget, the model shows the outer, middle, and inner ear with no compromise in quality. On base.

14 x 10 x 14.7 cm; 0.35 kg

1000252 \$69.00

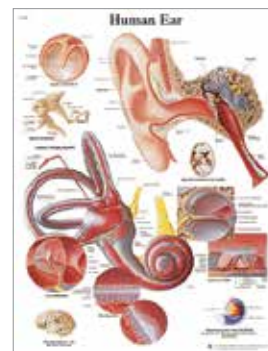

Human Ear Chart

50 x 67 cm (20 x 26")

1001500 \$21.00

4006667 \$14.00

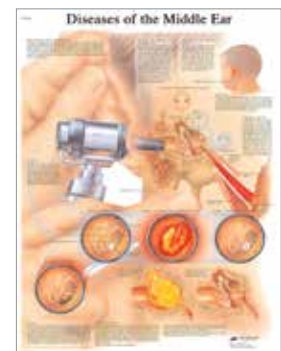

Diseases of the Middle Ear chart

50 x 67 cm (20 x 26")

1001506 \$21.00

4006670 \$14.00

More Charts Available online at 3bscientific.com or see pages 90-91.

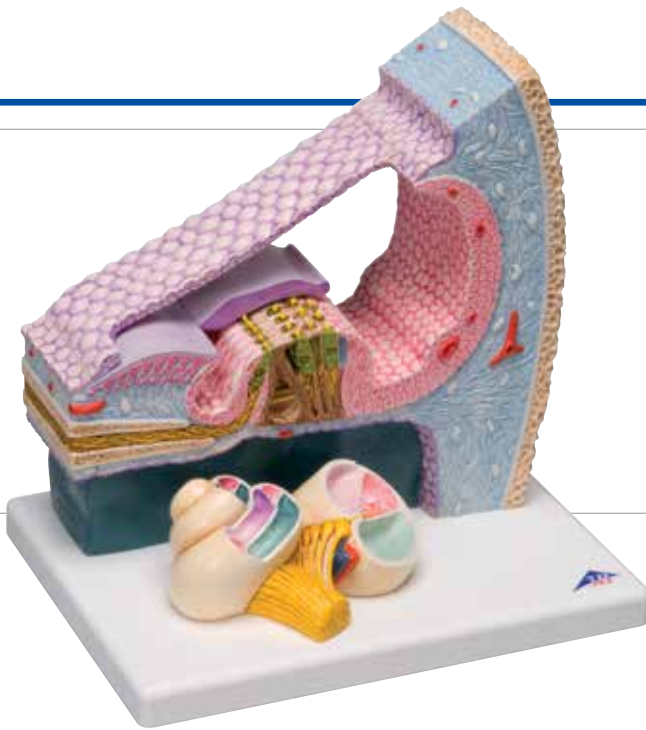

Organ of Corti

The model shows a three dimensional section through the organ of Corti, the site of the sense of hearing in the inner ear in humans. Special attention has been given to the detailed representation of the individual cellular components and membranes. The overview model in the foreground also shows the exact location of the organ in the cochlea.

26 x 19 x 26 cm
1010005 \$262.00

Nose Model with Paranasal Sinuses, 5-part

The upper right half of the face is enlarged 1.5 times to illustrate the structure of the nose with paranasal sinuses.

The following structures are differentiated by color and visible through the transparent removable skin:

- Outer nasal cartilages
- Nasal, maxillary, frontal, and sphenoidal sinuses
- Opened maxillary sinus when the zygomatic arch is removed

The following structures are shown in median section:

- Nasal cavity, lined with mucosa, with the (removable) nasal conchae
- Arteries of the mucous membrane
- Olfactory nerves
- Innervation of the lateral wall of the nasal cavity, the nasal conchae and the palate

26 x 19 x 24 cm; 0.8 kg

1000254 \$358.00

Opened maxillary sinus

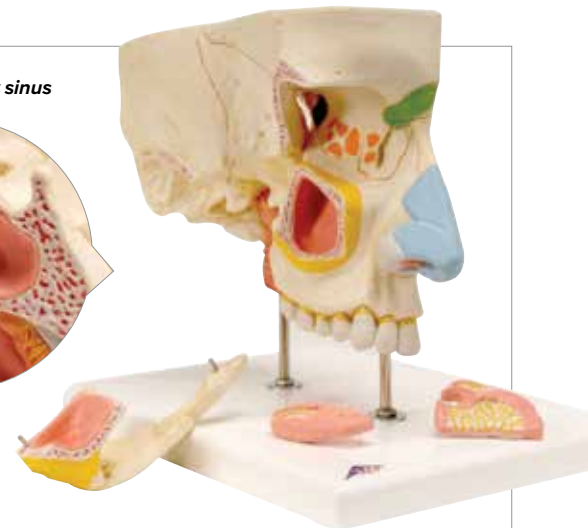
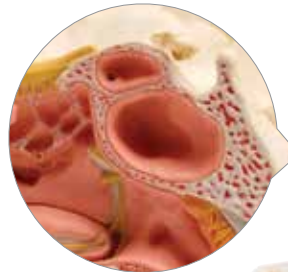

Life-size Auditory Ossicles

Cast from natural specimen, these human auditory ossicles are presented in their natural position and embedded in transparent acrylic.

0.05 kg

1000253 \$101.00

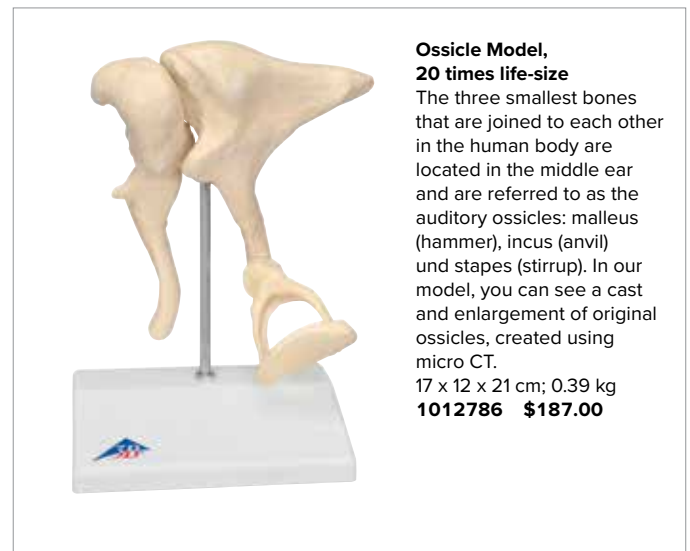

Ossicle Model, 20 times life-size

The three smallest bones that are joined to each other in the human body are located in the middle ear and are referred to as the auditory ossicles: malleus (hammer), incus (anvil) and stapes (stirrup). In our model, you can see a cast and enlargement of original ossicles, created using micro CT.

17 x 12 x 21 cm; 0.39 kg

1012786 \$187.00



Larynx, 2 Times Full-Size, 7-part
 This medially sectioned model shows: larynx, hyoid bone, windpipe, ligaments, muscles, vessels, nerves and thyroid gland. The Thyroid cartilage, 2 muscles and 2 thyroid gland halves are removable.
 On stand.
 12 x 12 x 23 cm; 0.8 kg
1000272 \$312.00



Functional Larynx, 2.5 Times Full-Size
 The epiglottis, vocal cords, and arytenoid cartilage are movable. **Additionally representing the following structures:**

- Hyoid bone
- Cricoid cartilage
- Thyroid cartilage
- Thyroid
- Parathyroid glands

14 x 14 x 28 cm; 0.8 kg
1013870 \$226.00



Pulmonary Lobule with Surrounding Blood Vessels
 The model shows the terminal branch of the bronchial tree with its further bifurcations, the associated pulmonary alveoli, as well as the surrounding blood vessels and their capillary networks in 130 times magnification. On the right side of the model, the pulmonary lobule is cut in order to facilitate view of the pulmonary tissue structure. The left side of the model shows a section of connective tissue located between adjacent pulmonary lobules. To better understand the gas exchange, a single opened pulmonary alveolus with the surrounding capillary network is shown at the back of the model in approx. 1,000-fold magnification. A graphic presentation on the base of the model shows the structure of the air passages located in the lung up to the pulmonary alveoli. 26 x 13 x 19 cm; 1.4 kg
1008493 \$319.00



Functional Larynx
 Epiglottis, vocal cords, and arytenoid cartilage are movable. Can be rotated on base.
 32 x 13 x 15 cm; 0.8 kg
1001242 \$301.00



Larynx, 2 Times Full-Size, 2-part
 This detailed larynx model is divided into two halves.
 9 x 9 x 14 cm; 0.15 kg
1000273 \$96.00

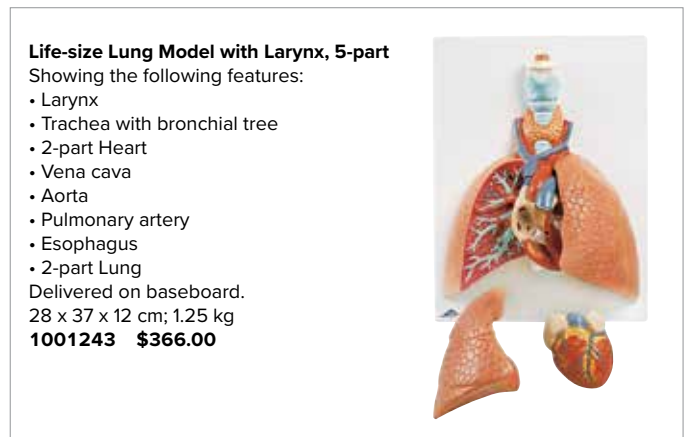

Life-size Lung Model with Larynx, 5-part
 Showing the following features:

- Larynx
- Trachea with bronchial tree
- 2-part Heart
- Vena cava
- Aorta
- Pulmonary artery
- Esophagus
- 2-part Lung

Delivered on baseboard.
 28 x 37 x 12 cm; 1.25 kg
1001243 \$366.00

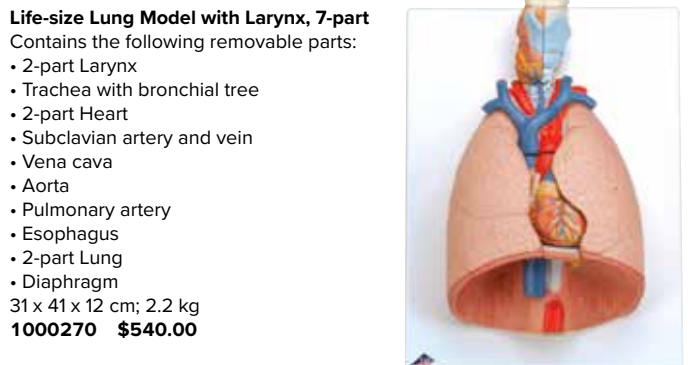

Life-size Lung Model with Larynx, 7-part
 Contains the following removable parts:

- 2-part Larynx
- Trachea with bronchial tree
- 2-part Heart
- Subclavian artery and vein
- Vena cava
- Aorta
- Pulmonary artery
- Esophagus
- 2-part Lung
- Diaphragm

31 x 41 x 12 cm; 2.2 kg
1000270 \$540.00

Segmented Lung, Magnetic, 20-part

This high quality lung model is detachable into two lobes and single segments. The segments are color-coded and their position can be easily identified in the bronchial tree. The bronchial tree contains the lobar bronchi and segmental bronchi. All segments are connected by magnets which allow a safe and easy handling.

25 x 25 x 35 cm; 4.1 kg
1008494 \$1,111.00

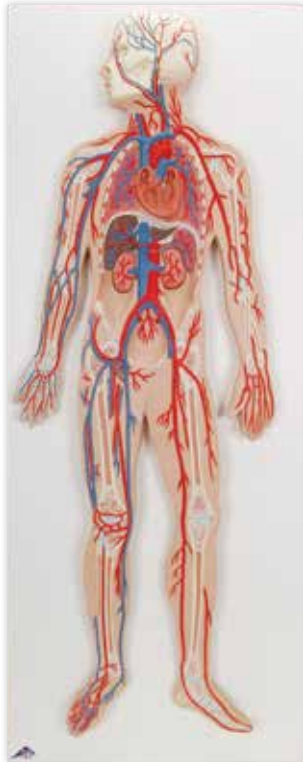
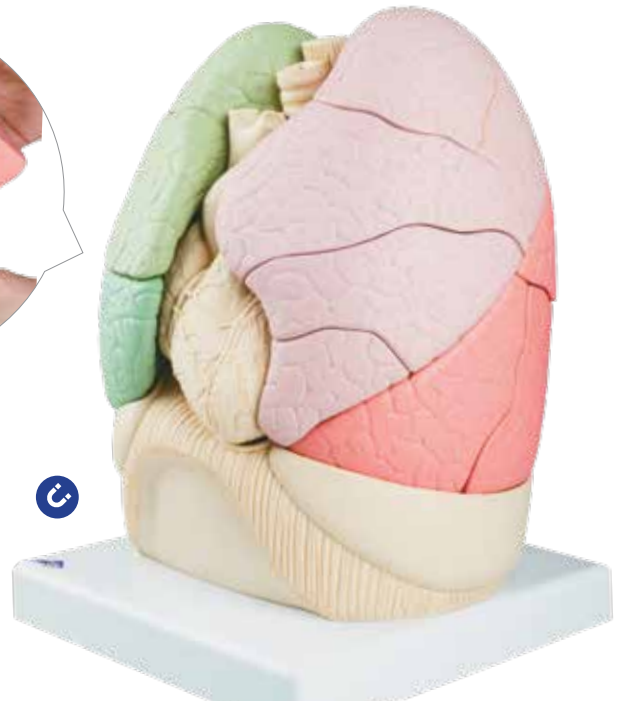

Human Circulatory System

Half life-size schematic representation of arteries, veins, capillaries, heart, lung, liver, spleen, and kidneys.

80 x 30 x 6 cm; 13.6 kg
1000276 \$325.00

MICROanatomy™ Artery and Vein

The model, enlarged 14 times, shows a medium sized muscular artery with two adjacent veins from the antebrachial area with adjoining fat tissue and muscle. The model illustrates the reciprocal anatomical relationship of artery and vein and the basic functional techniques of the venous valves ("valve function" and "muscle pump"). The left vein and the middle artery are fenestrated in the upper anterior segment, revealing the various layers of the wall structure in a cross and longitudinal section and in top view. The right vein is opened throughout in the anterior segment, revealing the orifice of a feeder vein and two venous valves, i.e. "flap valves" formed by a duplication of the tunica intima. On the back of the model, a relief of two veins illustrates the functional aspect of the venous valves. Supplied on base.

26 x 19 x 18.5 cm; 0.9 kg
1000279 \$349.00



A. CT Bronchial Tree with Larynx and Transparent Lungs

This unique model was created on the basis of computer tomography data of a human male. The larynx, with hyoid bone and epiglottis, and the trachea, with primary and lobar bronchi, are depicted in one color. The larynx is detachable at the level of the second tracheal cartilage and divisible in the median plane. The epiglottis is mounted flexibly. The various segmental bronchi are made of elastic material and depicted in various transparent colors so that they are easier to distinguish visually. The transparent lungs are detachable.

19 x 18 x 37 cm; 1.3 kg
1000275 \$754.00

B. CT Bronchial Tree without Lungs

22 x 18 x 37 cm; 0.42 kg
1000274 \$512.00

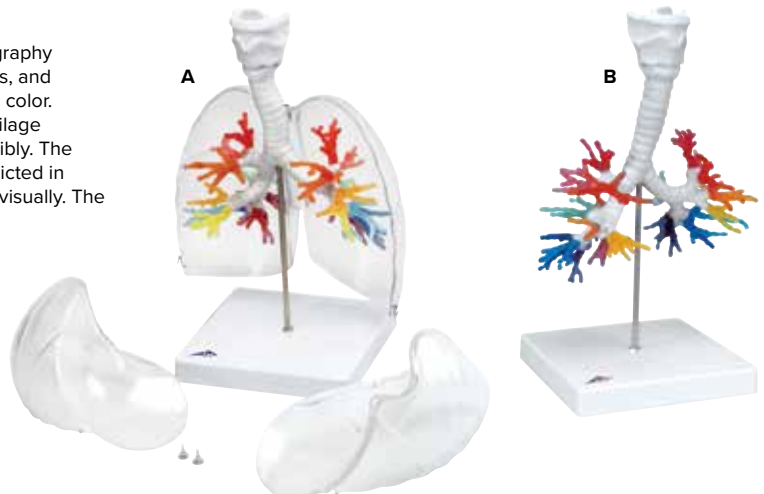

DENTITION MODELS

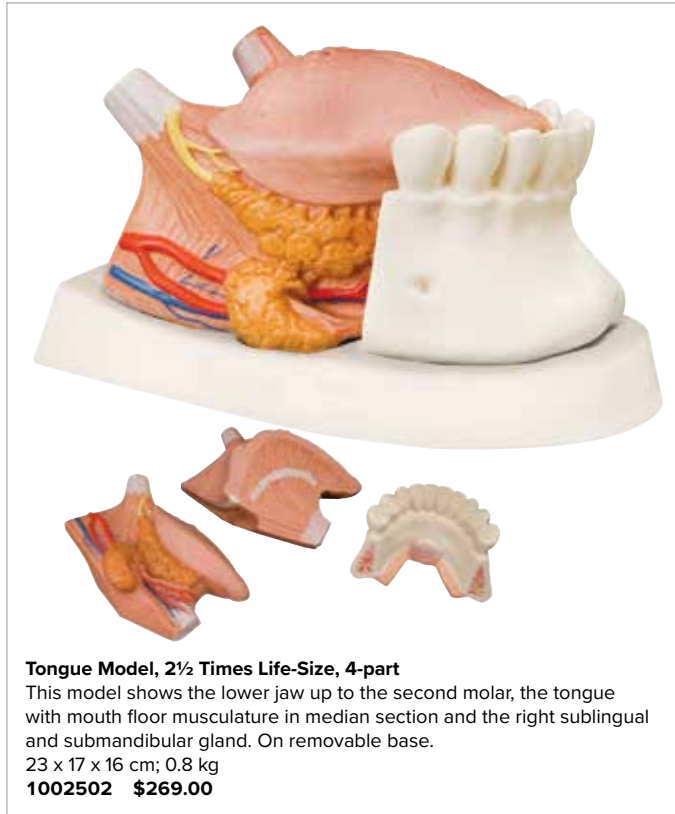

Tongue Model, 2½ Times Life-Size, 4-part

This model shows the lower jaw up to the second molar, the tongue with mouth floor musculature in median section and the right sublingual and submandibular gland. On removable base.

23 x 17 x 16 cm; 0.8 kg

1002502 \$269.00

Dentition Development

Cast from natural specimens, these four upper and lower jaw halves show four different stages of development:

- Newborn
- Approx. 5-year old child
- Approx. 9-year old child
- Young adult

33 x 10 x 20 cm; 0.58 kg

1000248 \$240.00

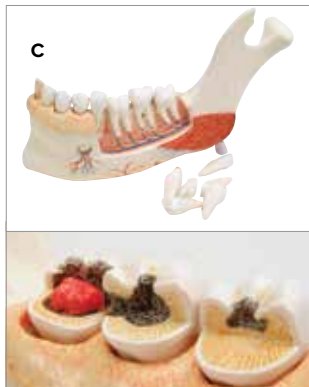

C

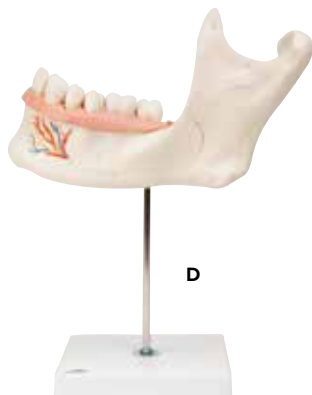

D

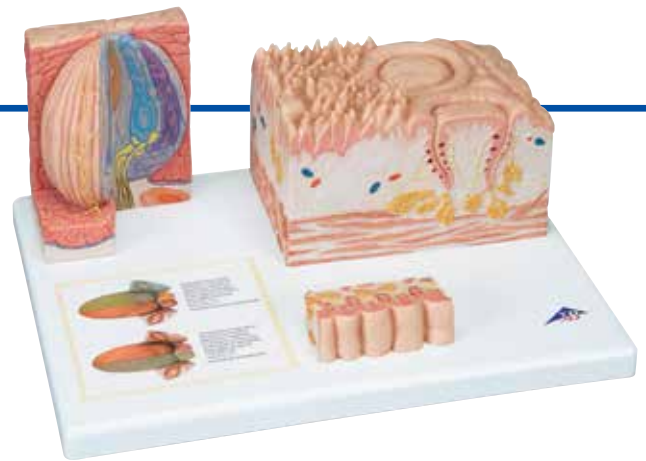

MICROanatomy™ Tongue

The 3B Scientific® MICROanatomy™ of the tongue comprises a macroscopic view of the tongue (dorsal view) and microscopic views of the various papillae of the tongue and of a taste bud. All views are mounted on a base that also features an overview of the sensory and sensitive innervations of the tongue.

14.5 x 32.5 x 20 cm; 0.8 kg

1000247 \$315.00

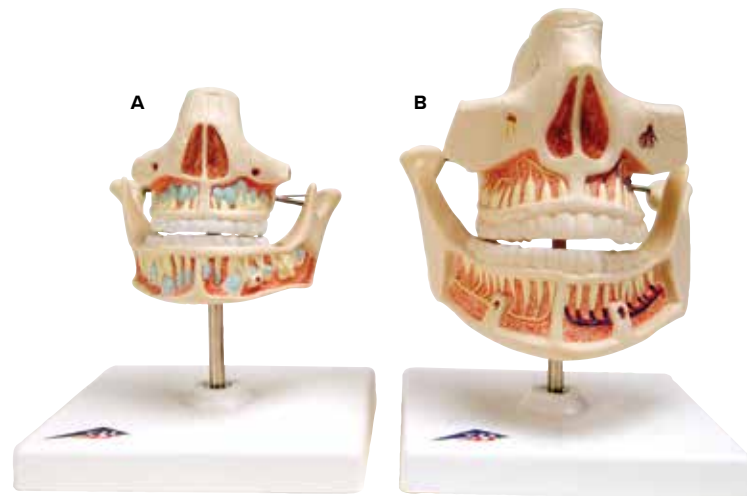

A

B

A. Milk Dentures

Upper and lower jaw are opened to show the arrangement of the remaining teeth. On base.

13 x 12 x 13 cm; 0.45 kg

1001248 \$206.00

B. Adult Dentures

Tooth roots, spongiosa, vessels, and nerves are exposed for detailed study. The lower jaw is movable. On base.

13 x 12 x 13 cm; 0.6 kg

1001247 \$206

C. Advanced Half Lower Jaw with 8 Diseased Teeth, 19-part

These diseased teeth show various stages of cavities from a small and easy-to-treat example on an incisor, through an advanced degradation of a molar, showing exposed root.

22 x 32 x 9 cm; 1.1 kg

1001250 \$332.00

D. Half Lower Jaw, 3 Times Full-Size, 6-part

One section of bone can be removed to expose the teeth roots, spongiosa, vessels, and nerves. The canine and first molar are removable and longitudinally sectioned. On stand.

35 x 18 x 36 cm; 1.2 kg

1000249 \$265.00



Jaw-shaped stand

Dental Morphology Series, 10 Times Life-Size, 7-part – English

At ten times life-size, this dental morphology series has removable lateral incisor, canine, first premolar, a bridge made of artificial first molar with gold colored crown and second molar. All relevant dental morphology structures are labeled. Dental morphology on transparent, jaw-shaped stand. Key card included.

70 x 25,5 x 15 cm; 2.1 kg
1005540 \$480.95

Giant Molar with Dental Cavities, 15 times Life-Size, 5 part

This giant molar model depicts an upper triple-root molar and separates into 5 parts. The molar features a longitudinal section through the crown, two roots and the pulp cavity.

The giant molar contains removable pulp and three tooth inserts with different stages of advanced cavities.

Delivered on stand.
 24 x 12 x 13 cm; 1.5 kg
1013215 \$281.00



Easily switched between 3 stages of cavities

Skull with Teeth for Extraction, 4-part

The teeth of the upper and lower jaw can be extracted and replaced individually with their fully-formed roots. A bone flap on the right mandible can be opened to view the dental roots, spongiosa, nerve canal, and an impacted wisdom tooth.

22 x 13.5 x 17 cm; 0.8 kg
1003625 \$212.00



Giant Dental Care Model

At 3-time life-size, this model is large enough to be seen from the back of a classroom. It shows the upper and lower half of an adult's dentition. Teach proper cleaning techniques using the giant 14" toothbrush included with this model.

18 x 23 x 12 cm; 1.5 kg
1000246 \$149.00

Replacement Parts
Giant 14" Toothbrush
1020738 \$36.00

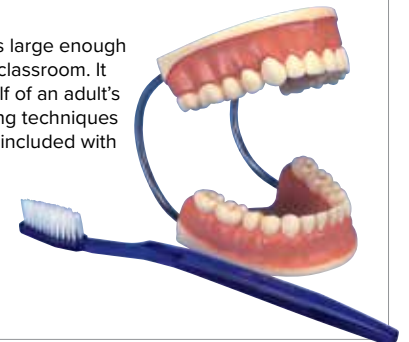

Dental Disease, magnified 2 Times, 21-parts
Magnified for easier demonstrations!

The model is based on a lower jaw with soft gums and 16 removable teeth. One half shows eight healthy teeth and healthy gums for comparison.

The other half shows the following dental diseases:

- Dental plaque
- Dental calculus (tartar)
- Periodontitis
- Inflammation of the root
- Fissure, approximal and smooth surface cavities

One part of the front bone section can be removed from the dental disease model to view the roots, vessels and nerves. Two molars are sectioned along the length to show the inside of the tooth.

Delivered on a base.
 17.5 x 26 x 18.5 cm; 0.6 kg
1000016 \$320.00



HEART MODELS

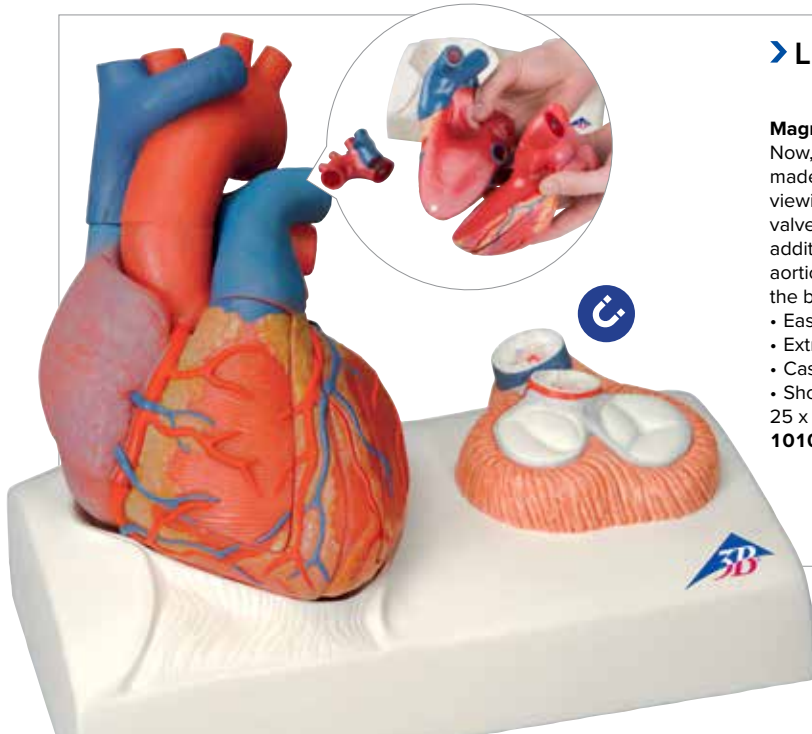

Life-size model cast from real specimen

Magnetic Heart Model, Life-Size, 5-part with Diastole and Systole

Now, in one detailed model, the study of diastole and systole is finally made straightforward and convenient. This unique dissection makes the viewing of the cardiac valves during diastole with closed pulmonary aortic valves and opened mitral tricuspid valves easier than ever before. In addition to this the closed mitral tricuspid valves and opened pulmonary aortic valves during systole are represented in a second model located on the base.

- Easy to open, magnetic connections
- Extremely detailed, life-size model
- Cast from real specimen
- Shows both diastolic and systolic state

25 x 21 x 13 cm; 1.52 kg

1010006 \$325.00

Hand-painted in life-like colors

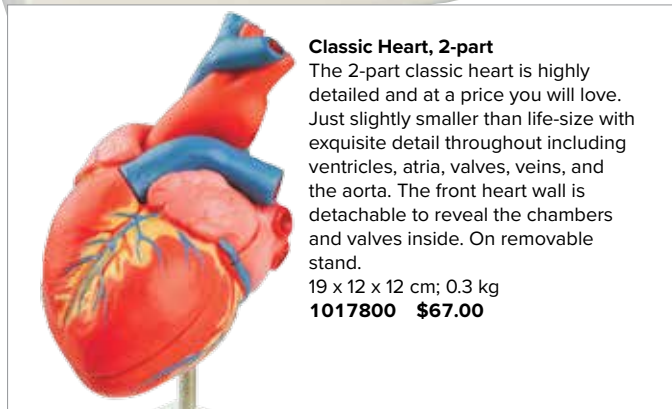

Classic Heart, 2-part

The 2-part classic heart is highly detailed and at a price you will love. Just slightly smaller than life-size with exquisite detail throughout including ventricles, atria, valves, veins, and the aorta. The front heart wall is detachable to reveal the chambers and valves inside. On removable stand.

19 x 12 x 12 cm; 0.3 kg

1017800 \$67.00

Hypertrophy



With Left Ventricular Hypertrophy

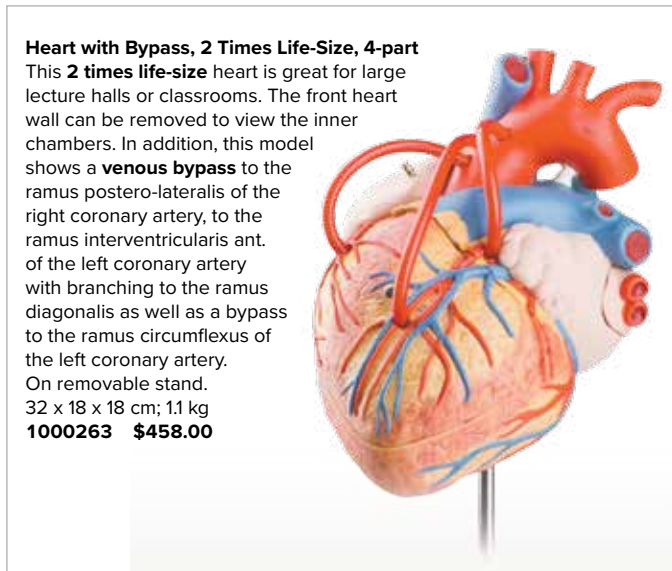

Heart with Bypass, 2 Times Life-Size, 4-part

This **2 times life-size** heart is great for large lecture halls or classrooms. The front heart wall can be removed to view the inner chambers. In addition, this model shows a **venous bypass** to the ramus postero-lateralis of the right coronary artery, to the ramus interventricularis ant. of the left coronary artery with branching to the ramus diagonalis as well as a bypass to the ramus circumflexus of the left coronary artery.

On removable stand.
32 x 18 x 18 cm; 1.1 kg
1000263 \$458.00

Classic Heart with Left Ventricular Hypertrophy (LVH), 2-part

In addition to all the features of the 2-part classic heart, this unique model shows the **long-term effects of increased heart activity due to high blood pressure**. The muscular wall of the left heart ventricle is considerably thickened and the tip of the heart is visibly rounded off. The front heart wall is detachable to reveal the chambers and valves inside. On removable stand.

12 x 12 x 14 cm; 0.45 kg

1000261 \$121.00

Classic Heart with Thymus, 3-part

Same features as G08 with addition of thymus.

20 x 12 x 12 cm; 0.3 kg

1000265 \$142.00



► **Magnified models for easy identification of all anatomical structures in the human heart.**

Heart, 2 Times Life-Size, 4 part

This 2 times life-size heart model allows very easy identification of all structures and is a perfect aid for lessons in big classrooms or lecture halls. The anatomy of the human heart is shown in great detail with ventricles, atria, valves, veins, and the aorta. The front heart wall can be removed to reveal the chambers and valves inside. Comes with a removable base and a multilingual product manual.

32 x 18 x 18 cm; 1.3 kg

1000268 \$371.00

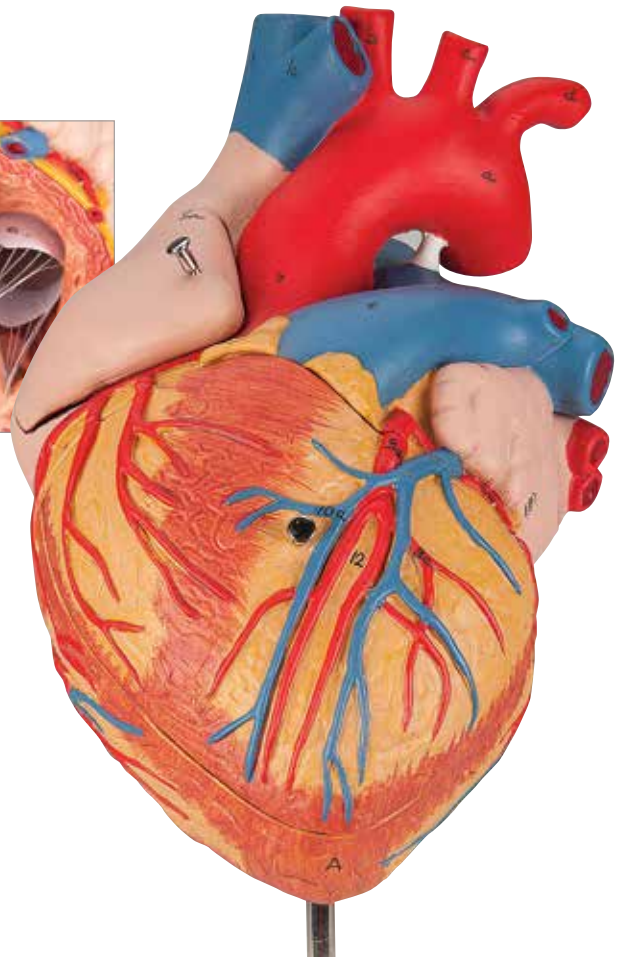
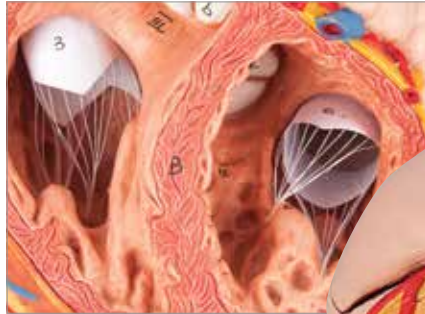

Classic Heart with Bypass, 2-part

With all the features of the 2-part classic heart, but also **includes venal bypasses** to the right coronary artery, to the ramus interventricularis anterior, and also to the ramus circumflexus of the left coronary artery, which are shown in colour. This model is a great aid in explaining coronary heart disease. On removable stand.

19 x 12 x 12 cm; 0.35 kg

1017837 \$113.00

Heart, 1.5 Times Life-Size, 7-part

This high quality model clearly shows over 30 different anatomical regions in the heart. Comes with product manual for easy identification of anatomical features. The model is horizontally sectioned at the level of the valve plane.

The following parts can be removed for detailed study:

- Oesophagus
- Trachea
- Superior vena cava
- Aorta
- Front heart wall
- Upper half of the heart

On base.

20 x 15 x 17 cm; 1.1 kg

1008548 \$390.00

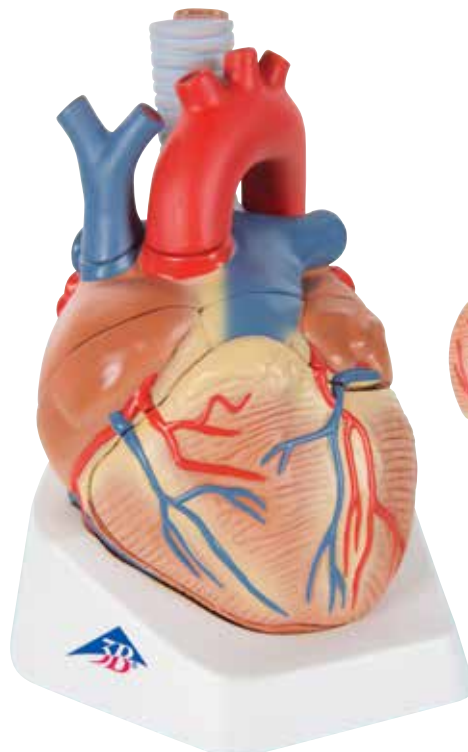

DIGESTIVE & URINARY SYSTEM MODELS

Stomach with Ulcers

This 3B Scientific® pathology model demonstrates various stages of gastritis, from a light gastric ulcer to a perforation. Mounted on base.

The stomach section, with esophagus and duodenum attachment in half life-size, shows the following pathological changes:

- Erythematous gastritis
- Erosive gastritis
- Hemorrhagic gastritis
- Healing stage with scar formation
- Atrophic gastritis
- Bleeding ulcer
- Perforated ulcer

An additional relief model of the enlarged stomach wall shows:

- Healthy mucous membrane
- Acute gastritis in the antral area
- Erosive gastritis with mucous membrane defects
- Bleeding ulcer (eroded muscularis mucosae)
- Perforated ulcer (all stomach layers eroded)

14 x 10 x 17 cm; 0.3 kg
1000304 \$77.00

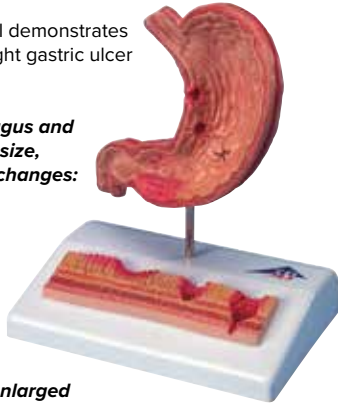

Digestive System, 3-part

This life-size model demonstrates the path food takes through the body during digestion. The duodenum, cecum, and rectum are opened. The liver, stomach, and transverse colon are removable. Mounted on baseboard.

The entire digestive system is illustrated in graphic relief featuring:

- Nose
- Esophagus
- Pancreas
- Spleen
- Mouth Cavity and Pharynx
- GI Tract

Liver with Gall Bladder
81 x 33 x 10 cm; 4.4 kg
1000307 \$509.00

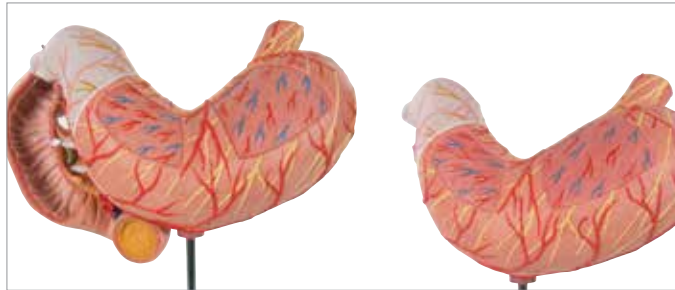

Stomach, 3-part

Shows the layers of the stomach wall from cardia to pylorus. The front stomach half and the opened duodenum with pancreas are removable. Delivered on removable stand.

Depicted are:

- Layers of stomach wall
- The lower esophagus
- Duodenum
- Pancreas
- Vessels
- Nerves

25 x 22 x 12 cm; 0.8 kg
1000303 \$296.00



Intestinal Villi, 100 Times Life-Size

Consisting of one entire villus, one longitudinally sectioned villus showing the arterioles and venules and one sectioned villus to show the lymphatic vessels. Also includes a longitudinal section of the crypt of Lieberkühn's. On base.

43 x 28 x 10 cm; 2.5 kg
1005532 \$360.95

MICROanatomy™ Digestive System

The model illustrates the structure of the fine tissues of four characteristic sections of the digestive system: The Esophagus, Stomach, Small intestine and Large intestine. The front of the model, from top to bottom, shows a magnified view, in histological section, of the individual sections of the digestive system and their fine tissue structures. The back of the model has highly magnified views of didactically interesting areas of each section shown on the front.

26 x 29.5 x 18.5 cm; 1.5 kg
1000311 \$321.00

Diseases of the Esophagus

Reaching from the lower part of the esophagus to the upper part of the stomach, this vivid, life-size frontal section shows many common conditions. See online for conditions shown.

14 x 10 x 19 cm; 0.19 kg
1000305 \$71.00



Liver with Gall Bladder

This realistic model shows the anatomy of the liver and gallbladder.

This realistic liver with gall bladder shows:

- 4 Lobes with gall bladder
- Extrahepatic ducts
- Hilus vessels.

18 x 18 x 12 cm; 0.5 kg

1014209 \$80.00

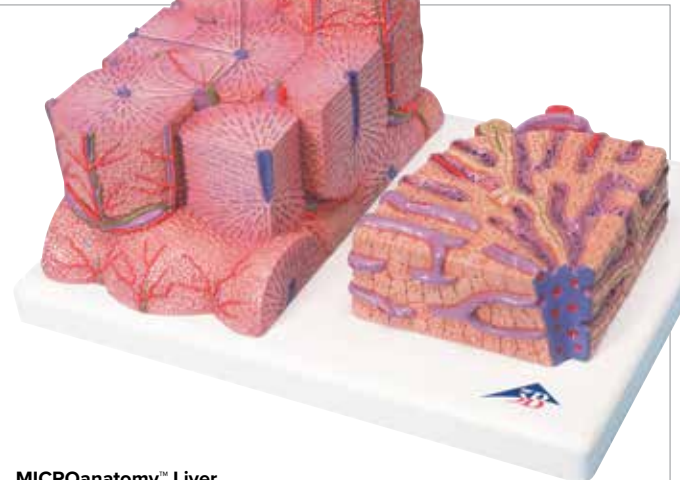

MICROanatomy™ Liver

This 2-part model shows a highly magnified view of a section of the liver. It illustrates the functional and structural components with two different enlargements. The left part shows a section of the liver that comprises several liver lobules. The right part of the model is a highly magnified view of the sectioned liver lobule on the left.

26 x 15 x 18.5 cm; 0.7 kg

1000312 \$320.00

Gallstone Model

The anatomy of the biliary system and its surroundings are shown at half natural size in this graphic model for education. Both acute inflammation and the tissue changes caused by chronic inflammation can be identified in the gallbladder wall. Mounted on base.

14 x 10 x 19 cm; 0.28 kg

1000314 \$77.00

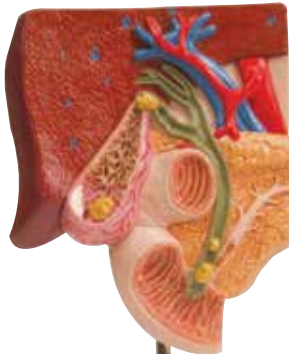

Liver with Gall Bladder, Pancreas and Duodenum

4 x 20 x 18 cm; 0.8 kg

1008550 \$143.00

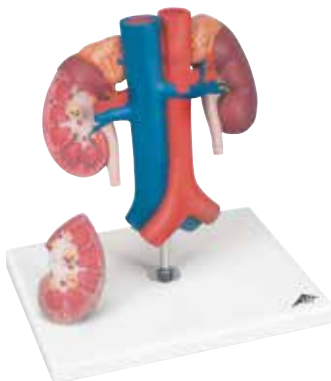

Kidneys with Vessels, 2-part

Life-size model presenting the kidneys with suprarenal glands, the outgoing ureters, the renal vessels, and the large vessels situated close to the kidneys. The front half of the right kidney can be removed to reveal the renal pelvis, the renal calices, the renal cortex, and the renal medulla. Comes on stand.

21 x 18 x 28 cm; 1.0 kg

1000308 \$183.00

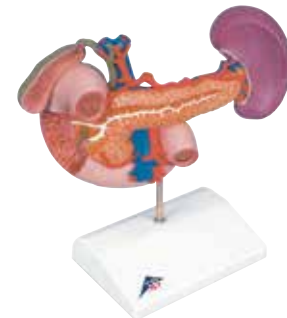

Rear Organs of Upper Abdomen

Representing the duodenum, which is partially opened, along with opened gall bladder and bile ducts. The model also includes the pancreas, revealing large ducts, the spleen, and the surrounding vessels, all in natural size. Comes on stand.

23 x 12 x 20 cm; 0.55 kg

1000309 \$183.00



Kidneys with Rear Organs

High quality kidney model with rear organs of the upper abdomen. A combination of models K22/1 and K22/2. The 3-part model includes upper abdominal organs which are attached in their natural positions and are removable from the kidneys. Comes on stand

24 x 18 x 29 cm; 1.4 kg

1000310 \$296.00



MICROanatomy™ Kidney

This extremely detailed model shows the functional units of the kidney greatly magnified.

Six model zones illustrate the following fine-tissue structures:

- Longitudinal section of a kidney
- Section of renal cortex and renal medulla of the kidney
- Wedge-shaped section of a kidney lobe with three nephrons with Henle's loops of different lengths and diagrammatic depiction of the vascular supply
- Nephron with a short Henle's loop and didactic illustration of the vascular supply
- Opened renal corpuscle with nephron and light-microscopic transverse sections of the proximal, attenuated and distal segments of a renal tubule

Mounted on a base. 23.5 x 25.5 x 19 cm; 0.95 kg

1000301 \$317.00

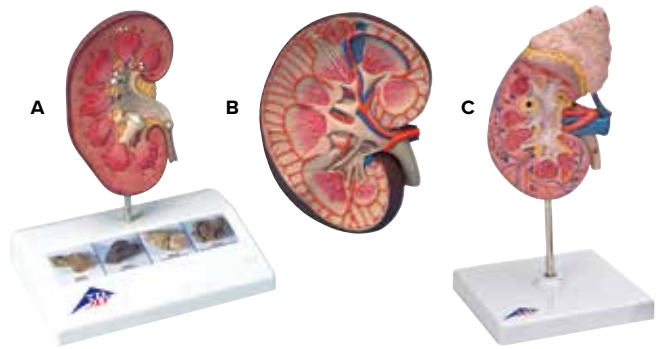

A. Kidney Stone Model

A great tool to inform patients about kidney stones and urinary stones. It shows an opened right kidney in natural size. The renal calices, the renal pelvis, and the ureter are opened as well enabling concretions or stones to be identified in the following typical positions:

- In the area of the renal pyramids
- In the area of origin of the upper calix group
- In the renal cortex
- In the connecting tubule of the lower calix group, causing congestion of the minor calices (partially closed, partially opened) in the ureter
- 4 original color pictures on the base show various kidney stones.

14 x 10 x 16.5 cm; 0.3 kg

1000316 \$77.00

B. Kidney Section, 3 Times Full-Size

This colorful and anatomically accurate model depicts a longitudinal section of the human right kidney. All important structures of the human kidney are shown. No baseboard included.

8.5 x 19 x 26 cm; 0.67 kg

1000295 \$118.00

C. Kidney with Adrenal Gland, 2-part

The front half of the kidney is removable to enable demonstration of cortex medulla and vessels for teaching about the human kidney.

The renal pelvis of the kidney is also displayed. 20 important structures of the human kidney are included in the anatomy key. Kidney with adrenal gland model comes on stand.

This high quality human kidney model shows:

- Kidney with adrenal gland
- Renal and adrenal vessels of the kidney
- Upper portion of ureter for the human kidney

20 x 12 x 12 cm; 0.47 kg

1014211 \$107.00

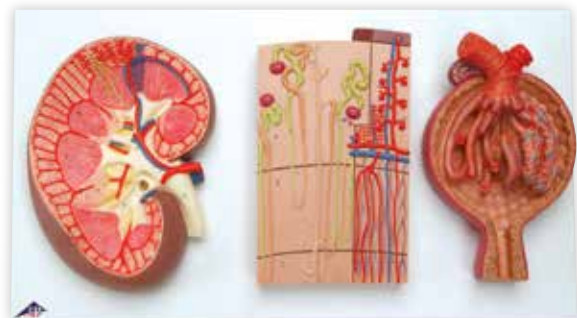

Kidney, Nephrons, Blood Vessels and Renal Corpuscle

These 3 kidney models create a complete series to study the anatomy of the kidney and the different structures of the kidney in great detail. All important structures are numbered and identified in the product guide.

Together they show:

- A longitudinal section of the right kidney, 3 times life-size (K10)
- A nephron depicting a section through renal cortex and medulla
- An opened Malpighian corpuscle with glomerulus and Bowman's capsule

Mounted on base. 29 x 52 x 9 cm; 2.55 kg

1000299 \$423.00



Inguinal Hernia Model

A useful model to help inform patients before undergoing surgical interventions. This natural-sized, graphic model shows the anatomical structures of a male groin with an indirect inguinal hernia, opened in layers. Two illustrations on the base allow for a comparison of direct and indirect hernias. Mounted on base.

14 x 10 x 18 cm; 0.41 kg

1000284 \$80.00



Hemorrhoid Model

The model is a life-size frontal section of the rectum as well as a smaller relief on a pedestal. In addition to the anatomical structures of the rectum (sphincter, mucous membrane, venous plexus), the model shows internal hemorrhoids during stage I and II as well as external hemorrhoids.

The relief exhibit shows hemorrhoids during stage III and IV. Mounted on base.

14 x 10 x 14 cm; 0.32 kg

1000315 \$71.00

A. Dual-Sex Urinary System, Life-Size, 6-part

All in one model of the human urinary system. One front half kidney is removable; easy to change male insert (bladder and prostate, front and rear half) and female insert (bladder, womb and ovaries, 2 lateral halves). On baseboard. See online for full features.

41 x 31 x 15 cm; 2.3 kg
1000317 \$565.00

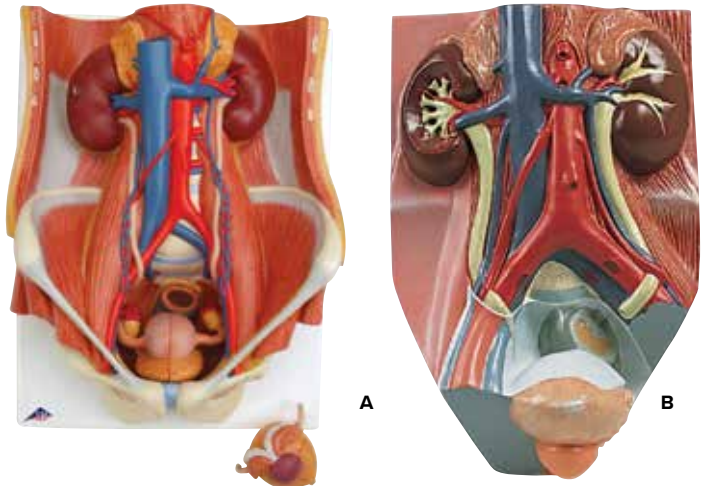

B. Male Urinary System, 3/4 Full-Size

This urinary system model shows the structures of the retroperitoneal cavity in high detail. The right kidney of the male urinary system model is opened. See online for full details and list of structures represented. Urinary system model is not delivered on base.

10 x 18 x 26 cm; 1.0 kg
1008551 \$193.00



C



D

Female & Male Pelvis, 2-part

These life size models present a median section to show the normal position of organs within the adult pelvis. One half of the reproductive organs along with the bladder and rectum are removable. Each is delivered on a baseboard and can be wall mounted if desired.

Pelvic skeleton features:

- Natural Cast
- Medical Quality
- Unbreakable Durable Plastic



C. Female Pelvis

41 x 31 x 20 cm; 2.2 kg
1000281 \$226.00



D. Male Pelvis

41 x 31 x 17 cm; 2.5 kg
1000282 \$226.00



E. Female Pelvic Skeleton

Consisting of hip bone, sacrum with coccyx, and two lumbar vertebrae; including movable symphysis.

19 x 25 x 24 cm; 0.9 kg
1000134 \$73.00

E



F. Female Pelvic Skeleton w/ movable Femur Heads

This realistic pelvic skeleton model consists of hip bone, sacrum with coccyx and 2 lumbar vertebrae as well as movable symphysis.

30 x 30 x 20 cm; 1.2 kg
1000135 \$89.00

F

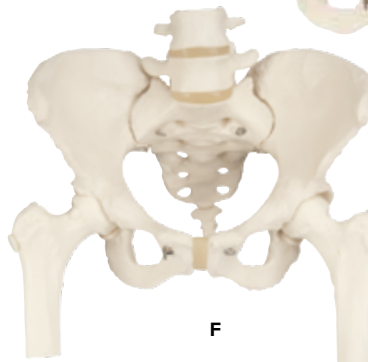

G. Male Pelvic Skeleton

Consisting of hip bone, sacrum with coccyx and two lumbar vertebrae.

18 x 28 x 23 cm; 0.8 kg
1000133 \$75.00

G



PELVIS & PELVIC SKELETON MODELS

> NEW

3B Scientifics new "Bungee" pelvic bone models are naturally cast from a female pelvis. All the pelvic bones are flexibly mounted and can be easily disassembled. Available with or without femur heads, these models perfectly demonstrate the articulation of the pelvic joints. Highly suitable for patient education as well as being a useful learning tool for midwives and in the areas of Obstetrics, Gynaecology and Orthopaedics.



Flexible Female Pelvis with Femur Heads
1019865 \$127.00

> Moulded from durable and soft vinyl!



Female Pelvic Skeleton with Genital Organs, 3-part

This model is especially suitable for studying the position of female genital organs in the pelvis. It consists of a natural cast female pelvis with a movable symphysis, hip bone, sacrum, coccyx, 4th and 5th lumbar vertebrae, and a female genital insert with rectum. The bladder and a portion of the uterus with one fallopian tube and ovary can be removed. The soft tissues are molded from durable, soft vinyl.

Delivered on base.
33 x 26 x 18 cm; 1.94 kg
1000335 \$300.00



Flexible Female Pelvis
1019864 \$115.00

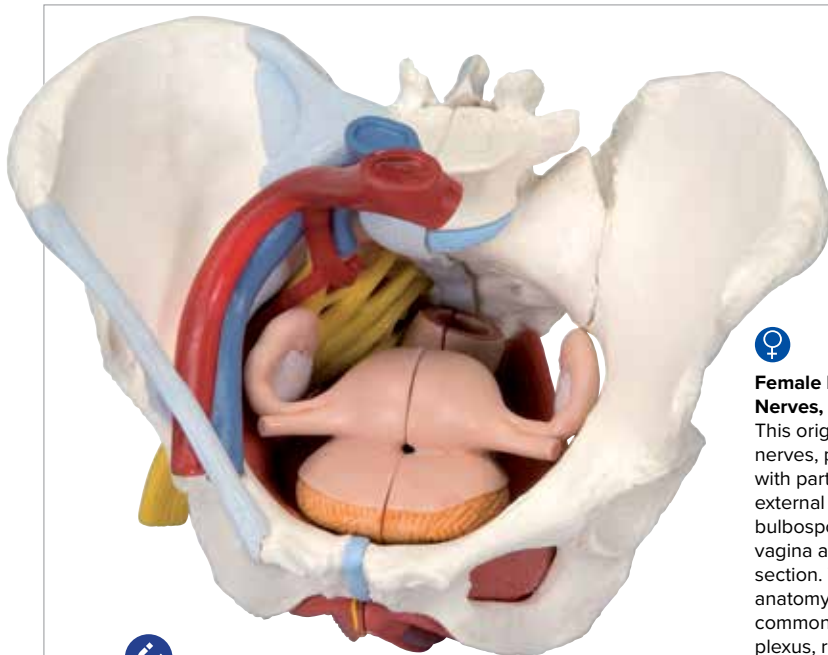

Female Pelvis with Ligaments, Vessels, Nerves, Pelvic Floor and Organs, 6-part

This original cast of a female pelvis shows bones, ligaments, vessels, nerves, pelvic muscles and organs. The whole pelvic floor is represented with partially removable midsagittally sectioned external anal sphincter, external urethral sphincter, deep and superficial transverse perineal and bulbospongiosus. Rectum, uterus with fallopian tubes and ovaries and vagina are removable and can be disassembled into halves by midsagittal section. The right pelvic half demonstrates the divisions and topographical anatomy of the common iliac artery, the external and internal artery, the common iliac vein and the external iliac vein. In addition the right sacral plexus, right sciatic nerve and right pudendal nerve are shown.

19 x 27 x 19 cm; 2.274 kg
1000288 \$682.00

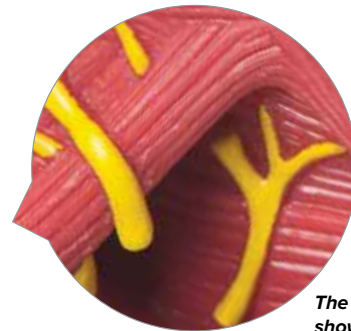

The pelvic muscles are shown in great detail



Female Pelvis with Organs, Pelvic Floor & Ligaments, 4-part

Bones, ligaments, and pelvic floor muscles with pelvic organs midsagittally sectioned to illustrate their relationship to the pelvic floor muscles.

19 x 27 x 19 cm; 1.755 kg

1000287 \$536.00



Female Pelvis with Ligaments, 3-part

Accurately presenting the following ligaments: Inguinal, sacrotuberous, sacrospinous, anterior sacroiliac, iliolumbar, anterior longitudinal, interosseous sacroiliac, posterior sacroiliac and obturator membrane.

19 x 27 x 19 cm; 1.8 kg

1000286 \$322.00



Female Pelvis, 3-part

Detailing the structures of the bony pelvis: Hip bones, pubic symphysis, sacrum, coccyx, L5 (removable) with intervertebral disc. Sacrum and the coccyx can be disassembled to show part of the cauda equina in the vertebral canal.

19 x 27 x 19 cm; 1.38 kg

1000285 \$266.00



Male Pelvis, 3-part

This 3-part model is a natural cast of a male, bone pelvis. It shows all anatomical structures in detail: both hip bones, pubic symphysis, sacrum and coccyx as well as the fifth lumbar vertebra with intervertebral disc. A median section has been placed through the fifth lumbar vertebra, the sacrum and the coccyx, so that the pelvis, which is held together by practical magnets, can be split into two halves. This means that part of the cauda equina is also visible in the vertebral canal. The left half of the fifth lumbar vertebra is held together by magnets and can also be removed.

19 x 28 x 24.5 cm; 1.34 kg

1013026 \$272.00



Male Pelvis with Ligaments, 2-part

This 3-part model is a natural cast of a male, bone pelvis. It shows all anatomical structures in detail: both hip bones, pubic symphysis, sacrum and coccyx as well as the fifth lumbar vertebra with intervertebral disc. A median section has been placed through the fifth lumbar vertebra, the sacrum and the coccyx, so that the pelvis, which is connected by practical magnets, can be split easily into two halves. This means that part of the cauda equina is also visible in the vertebral canal.

19 x 28 x 24.5 cm; 1.65 kg

1013281 \$342.00

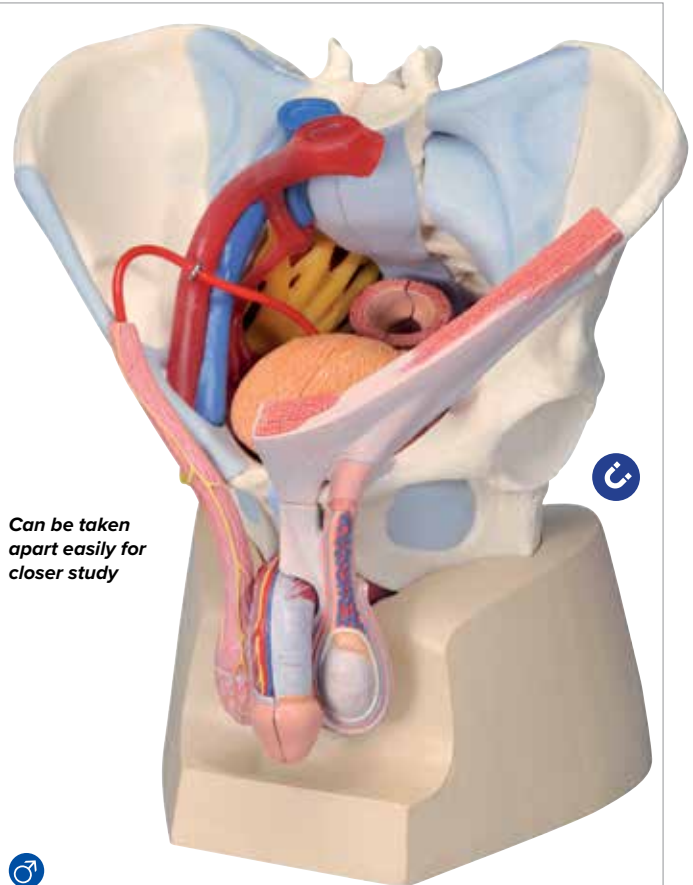

Can be taken apart easily for closer study



Male Pelvis with Ligaments, Vessels, Nerves, Pelvic Floor and Organs, 7-part

Extensive educational tool for a better understanding of the comprehensive anatomy of the male pelvis. For close up study, the pelvis can be split into two halves and the following parts can be removed: Left half of the fifth lumbar vertebra, rectum, bladder, prostate and penis.

- Includes bones, ligaments, vessels, nerves, pelvic floor muscles, and external sex organs
- All structures are anatomically accurate in every detail
- Can easily be taken apart using magnetic connections
- Extremely durable material, comes on sturdy base

21 x 28 x 31 cm; 3.12 kg

1013282 \$709.00

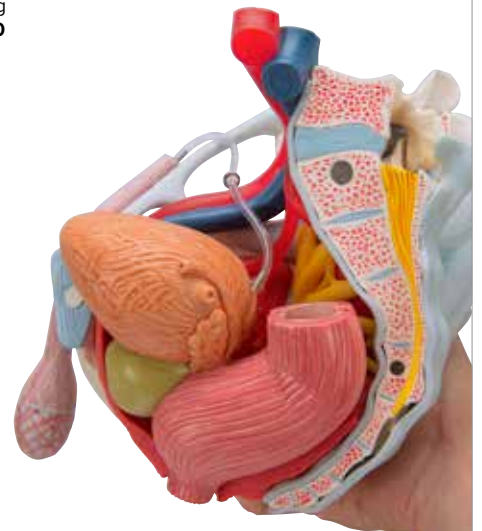



HEALTH EDUCATION

High quality and functional products to educate about common health risks and diseases. Ideal for educating patients and for student training.

REPRODUCTIVE EDUCATION



Teen BSE/TSE Training Set

This kit contains a teen BSE model and a TSE model to teach teens the importance of the early detection of cancer. Teen BSE model contains lumps in a variety of sizes. TSE model contains two lumps in each testicle. Each model is made of soft, durable BIOLIKE 2™ synthetic tissue and comes with slipcover and carrying case.

26 x 22.9 x 18.8 cm; 0.9 kg

Beige Skin Tone 1017933 \$217.00

Brown Skin Tone 1017934 \$217.00



Four embedded, simulated tumours

Testicle Self Exam

By using 3B Scientific SKIN/like™ high-quality silicone, learning and practicing self-examinations of the testicles becomes even more realistic. The scrotum contains two movable testicles, the epididymi, and the spermatic cords for palpation. Two pathological findings can be felt in the left testicle. Supplied with detailed instructions for self-examination and a carrying bag.

9 x 8 x 4 cm; 0.19 kg
1000346 \$251.00



Testicle Self Exam Simulator

Self-examination of the testicles is just as important as self-examination of the female breasts for early detection of tumors. Providing exceptional realism, this simulator features soft, thin outer skin with delicate underlying structures and four embedded, simulated tumors. Ideal for teaching proper palpation techniques. To maintain the lifelike feeling of the skin, baby powder (included) should be applied from time to time.

23.5 x 16 x 6.5 cm; 0.475 kg

1005640 \$137.00



Realistic replica

Male Pelvis Section, 1/2 Life-Size

A cross section of the male genital organs showing all anatomical structures in detail.

13.5 x 10 x 14 cm; 2.4 kg

1000283 \$69.00



Condom Training Set

This economy set has 20 styrofoam penis models and provides a means of practicing the correct use of condoms, even in large groups. The reusable models can be fixed to the desktop with adhesive tape. Delivered without condoms. 14.5 cm

1005115 \$68.00



Condom Training Kit

Use this model to quickly teach how to use a condom safely. The anatomical structures and its firmness are realistic, so that training to put on and remove a condom happens in a realistic way. Supplied with 12 lubricated training condoms and a carrying bag.

7.5 x 7.5 x 19.5 cm; 0.35 kg

Light Skin Tone 1000340 \$108.00

Dark Skin Tone 1000341 \$108.00



Condom Training Model

Demonstrate the proper use of condoms by using this realistic model. Includes 12 condoms, syringe, and artificial semen to simulate ejaculation.

Mounted on a stand with suction cups and delivered with carrying bag.

35.5 x 15 x 16.5 cm; 2.30 kg

Light Skin Tone 1005560 \$190.00

Dark Skin Tone 3004583 \$190.00

Optional Equipment:

UV-Fluorescent Artificial Semen

1005561 \$10.48



Female Condom Model

This model shows the labia and vagina up to the cervix and is designed to demonstrate and teach the insertion of a female condom.

(Condoms not included).

12 cm; 0.15 kg

Dark skin tone 1000338 \$114.00

Light skin tone 1000339 \$114.00



Female Pelvis Contraceptive Model

This model, made from soft BIOLIKE™ material, provides a crosssection of a female pelvis for demonstrating proper contraceptive insertion. The side cutout lets viewers see and understand contraceptive placement and removal. *(Contraceptives not included).*

15 x 8 x 9 cm

1017935 \$106.00

Removable parts



AIDS Virus

This model has been enlarged millions of times to show the outer lipid membrane with protein structures and the internal nucleus which contains the viral hereditary matter (RNA). Remove the nucleus and you'll find space to place a targeted message regarding measures to take in protecting against HIV. Mounted on base.

18 x 13 x 13 cm; 0.6 kg

1000336 \$94.00



Female Condom Model

Represents an anteverted uterus in a simulated pelvic cavity with soft vulva and vagina and a soft plastic stomach cover. A perfect tool to demonstrate the use of a female condom, contraceptive sponge and cervical cap.

Supplied with carrying bag.

17.8 x 24 x 14 cm

1005826 \$160.00



The Consequences of HIV/AIDS 3D Display

This 3D display helps viewers to understand what HIV/AIDS can do to the body. Contained within a convenient carrying case for storage or transport. 71 x 69 cm opened.

1018281 \$413.00

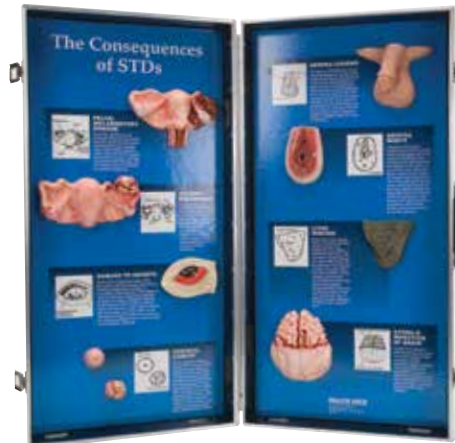

The Consequences of STDs 3D Display

This 3D display shows how organs and body parts can be affected by sexually transmitted diseases. The durable carrying case and easy set-up make this display ideal for clinics and sex education programs.

71 x 69 cm opened.

1018280 \$403.00

Wearable Breast Self Examination Model

Demonstrate realistic self-examination with our natural casting of a female upper body with medium sized breasts. It can easily be worn, in order to better train and practice breast self-examination.

- Made of new 3B SKINlike™ high-quality silicone
- Displays the skin in finest detail
- Very realistic to the touch and dermatologically tested
- Breast examination is possible in both upright or lying positions
- Benign and malignant tumors in different stages of development hone self-examination skills
 - 2 benign tumors
 - 4 malignant tumors
 - 2 typical anomalies
- Includes "Female Breast" chart
- Supplied with talcum powder, harness, stand and aluminium carrying case

56 x 44 x 24 cm; 11.5 kg

1000342 \$1,529.00

1000343 \$1,302.00 without chart and case



SKINlike™

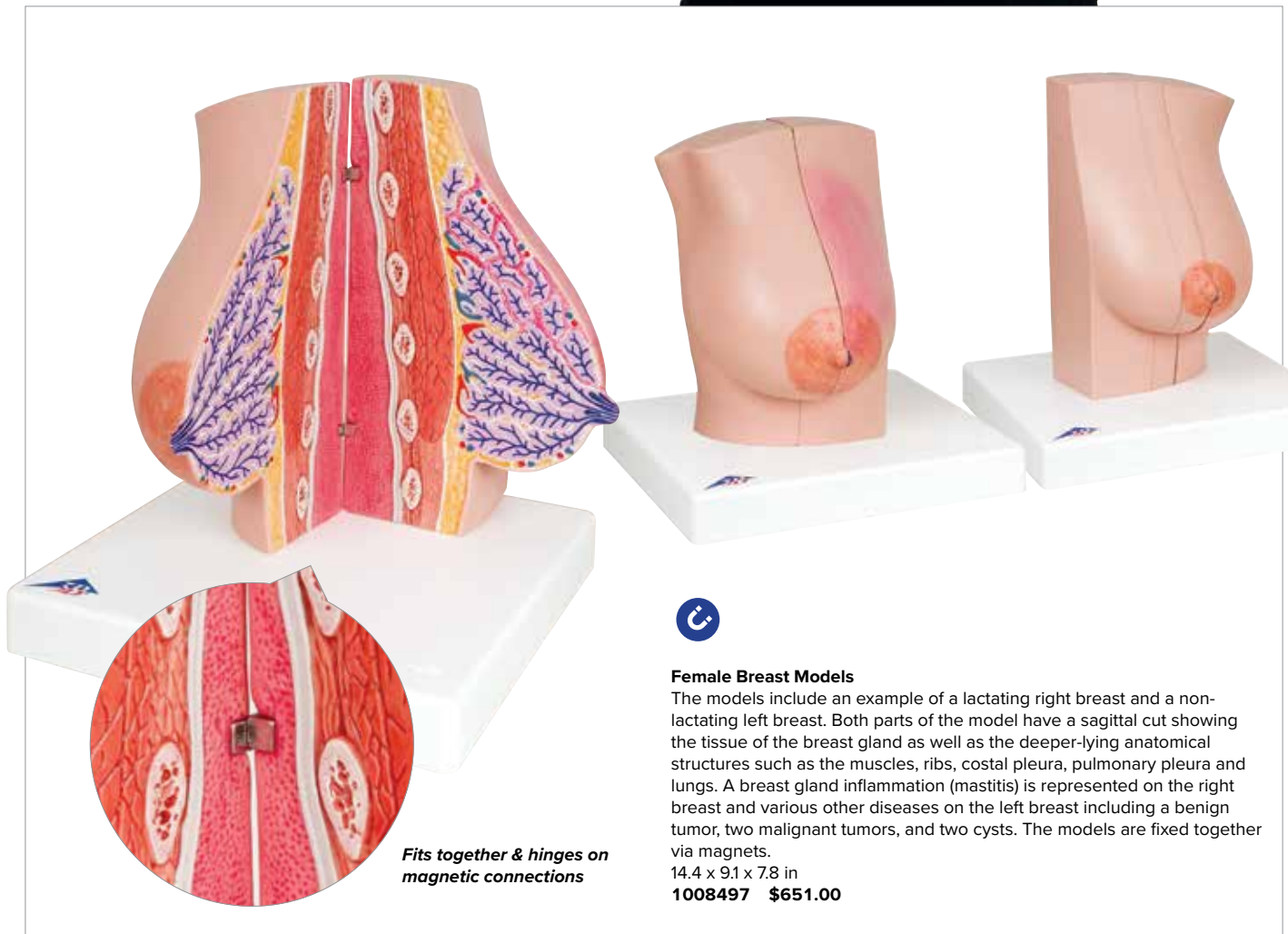

Fits together & hinges on magnetic connections



Female Breast Models

The models include an example of a lactating right breast and a non-lactating left breast. Both parts of the model have a sagittal cut showing the tissue of the breast gland as well as the deeper-lying anatomical structures such as the muscles, ribs, costal pleura, pulmonary pleura and lungs. A breast gland inflammation (mastitis) is represented on the right breast and various other diseases on the left breast including a benign tumor, two malignant tumors, and two cysts. The models are fixed together via magnets.

14,4 x 9,1 x 7,8 in

1008497 \$651.00

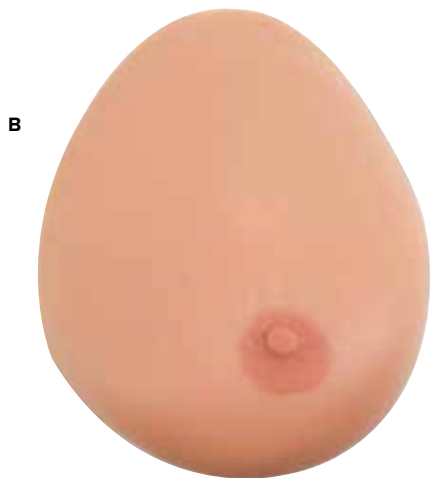

Breast Self Examination Model

Very realistic natural casting of three different female breasts in C and D cups, to train and practice breast examination. Supplied with base and talcum powder.

- Made of new 3B SKINlike™ high-quality silicone
- Benign and malignant tumors in different stages of development are featured in two breasts
- A healthy breast is supplied for comparison

52 x 24.5 x 9.5 cm; 2.3 kg

A. 1000344 \$616.00

B. 1000345 \$141.00 single breast only

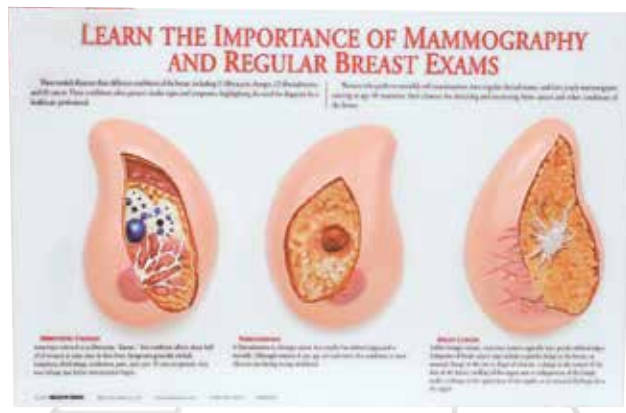

The Importance of Mammography Display

These handpainted, 3D breast models feature the anatomy of three different breast diseases. Breasts with fibrocystic condition, a fibroadenoma and a malignant tumor are depicted.

Comes with wire easel.

43.2 x 27.9 cm

1018283 \$279.00

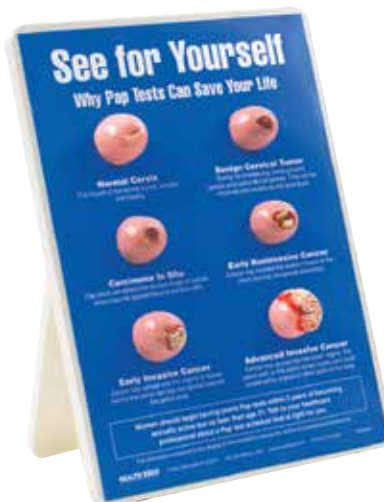

Why PAP Tests Can Save Your Life Easel Display

Easy-to-understand text combined with six handpainted, realistic cervix models make teaching the importance of regular PAP tests easy. This 3D display is perfect for one-on-one presentations. Comes with a protective felt cover.

23 x 30.5 cm

1018296 \$126.00



How to Perform Breast Self Examination (BSE) Chart

This chart explains basic procedures for vertical/grid, circular, and wedge patterns and includes recommendations on when and where to perform BSE. Also lists possible warning signs of breast cancer.

An excellent teaching resource. Laminated.

45.7 x 61 cm

1018312 \$20.00

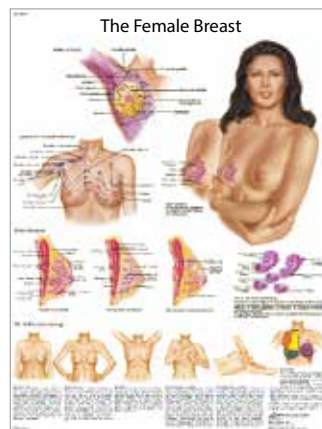

Female Breast Chart - Anatomy, Pathology and Self-Examination

This colorful chart covers the anatomy, pathology, and self-examination of the human female breast. The anatomy of breast pathology is shown along with useful information about different types of breast lumps that can occur.

50 x 67 cm

1001576 \$21.00

4006705 \$14.00

PREGNANCY & BIRTH



Embedded Placenta

This corrosion cast specimen of a human placenta is embedded in crystal-clear plastic. Detailed spatial portrayal of vessel arborization and progression as well as the placental villi is achieved by injecting different colored plastics into the placental vessels: red in the placental arteries and blue in the placental veins. The specimens vary in shape as each is unique.

21 x 17 x 4 cm; 0.5 kg
1003645 \$617.00

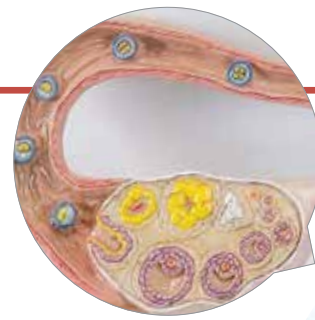

Easy to understand model for patient education

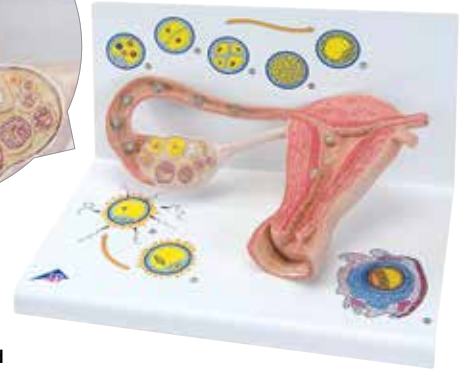

Stages of Fertilization and The Development of The Embryo, 2 Times Life-Size

Schematic illustrations show how an ovum matures, how ovulation and fertilization occur, and how the fertilized ovum develops to the point of embedding itself in the womb wall to begin growth into an embryo. The various stages are shown in larger-than-life model form in an ovary, fallopian tube, and womb. An even more enlarged illustration of each is printed on the base.

35 x 21 x 20 cm; 1.2 kg
1000320 \$349.00

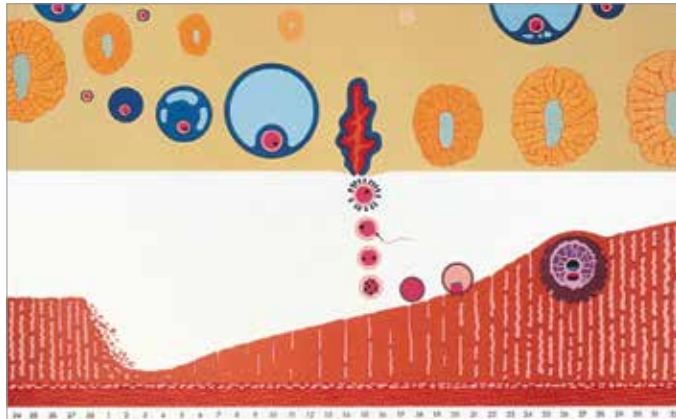

Visual Anatomy Oversize Wall Charts

A valuable educational supplement for use in schools, universities and medical facilities. These impressive charts are supplied with a detailed, six-language product manual including scientifically correct nomenclature. Printed on waterproof, tear resistant paper each chart is available with (M) or without (U) wooden mounting rods. Please add the appropriate suffix to the product number to indicate your mounting preference.

Menstrual Cycle & Ovum Implantation

1001220 \$43.00 Mounted

Embryology I

4006560 \$26.00 Unmounted
1001222 \$40.00 Mounted



Embryonic Development Model in 12 stages

The model represents the development of the human germ cells from fertilisation until the end of the 2nd month of pregnancy in 12 stages. Each stage can be removed from the common stand as an individual part and can be purposefully used for teaching and tests for the embryological specialist field.

65 x 34.5 x 6 cm; 1.55 kg
1001257 \$613.00

> 25 times life-size

Human Embryo Model, 25 Times Life-Size

This human embryo model shows the anatomy of an embryo at approximately 4 weeks old. At 25 times life size this human embryo is great for studying human development. The high quality model is affordable without sacrificing any anatomical detail.

12 x 12 x 23 cm; 0.3 kg
1014207 \$82.00

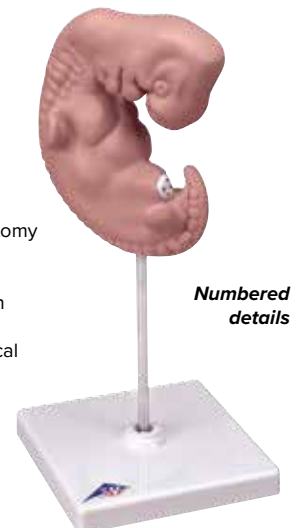

Numbered details

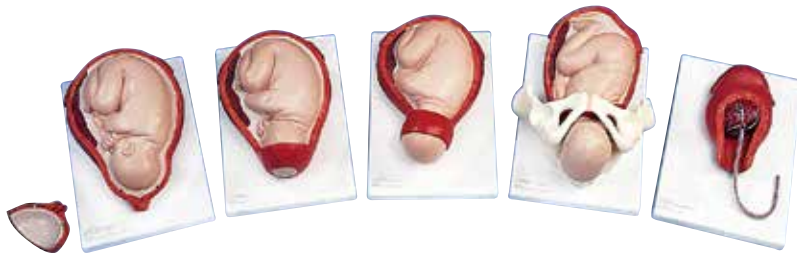

Birth Process, 5 Stages

Anatomical representation of human birth. 5 stages of the birthing process, mounted individually on bases.

- Fetus in womb, cervix closed; 2-part
- Fetus in womb, cervix open
- Fetus in womb, start of head passage
- Fetus in womb and pelvis, finish of head passage
- Placenta in womb

17 x 28 x 46 cm; 8.6 kg
1001258 \$953.00

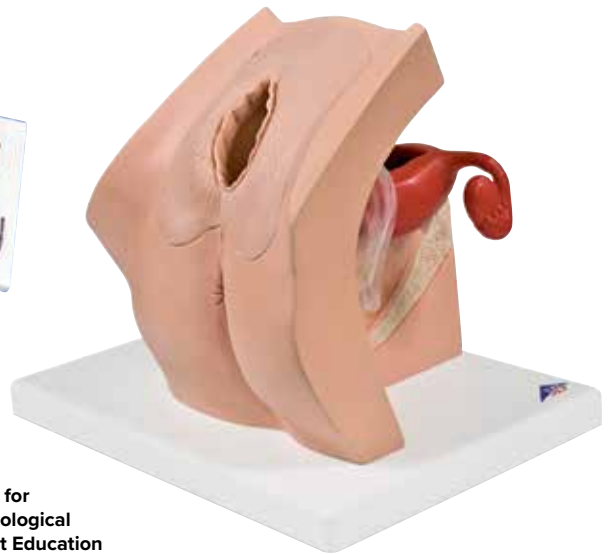

Model for Gynecological Patient Education

Ideal for demonstration purposes and for practicing insertion of female barrier contraceptive devices. Including the femidom, cervical cap, vaginal ring, diaphragm and IUD. It is possible to insert the various types of pessaries such as ring, bowl or cube which are used in the event of a prolapse or incontinence.

26 x 19 x 22 cm; 1.5 kg
1013705 \$395.00

Optional Kits:
Contraception Kit
1017130 \$279.00

Pessary Kit
1017131 \$328.00



Classic 3B Scientific® Pregnancy Series

Study human development from the 4th week through the 7th month. Our most popular series includes eight models to show the complete stages of development. All embryo or fetus models are shown in different typical positions in the uterus and each is mounted separately on an individual stand. The five later stages of development allow the fetus to be removed. Ask your Sales Rep about purchasing individual models or visit 3bscientific.com for product details.

12 x 12 x 19 cm; 3.2 kg

1018627 \$954.00

- 1st Month Embryo
- 2nd Month Embryo
- 3rd Month Embryo
- 4th Month Fetus (Transverse Lie)
- 5th Month Fetus (Breech Position)
- 5th Month Fetus (Transverse Lie)
- 5th Month Twin Fetuses (Normal Position)
- 7th Month Fetus

Pregnancy Pelvis, 3-part

This anatomy model is a representation of a median section through the female pelvis at 40 weeks pregnant with a removable foetus. Study or demonstrate the normal position of baby before birth with this model plus the human reproductive and urinary systems. A uterus with embryo in 3rd month of pregnancy is mounted on base for added detail and comparison. The realistic and high quality female pelvis includes the female genital organs and other important anatomical details.

38 x 25 x 40 cm; 3.80 kg
1000333 \$623.00



Median section with removable foetus

A. Labor Stages Model

Same as 1001258, but reduced in half. Supplied on baseboard. 40 x 31 x 13 cm; 1.4 kg
1001259 \$519.00

B. Standard 3B Scientific® Pregnancy Series

This series consists of five models to show the most important stages of development. Stages included: 1st month, 2nd month, 3rd month, 5th month, 7th month. The 5th and 7th month stages have detachable fetuses. All models are mounted together on a base. 13 x 41 x 31 cm; 2.1 kg
1018633 \$609.00



Empathy Belly

This unique pregnancy simulation allows both female and male wearers to experience over 20 symptoms and effects of being pregnant. Through the use of a rib belt and the strategic positioning of various weighted components, the Empathy Belly simulates many of the physical and emotional effects of being pregnant. This handon garment is a wonderful teaching and learning tool. For teenagers, the Empathy Belly provides a tangible example of what it means to be pregnant.

Small 1017929 \$750.00
Large 1017930 \$750.00



Ready or Not Tots®

The original manikin that simulates a baby's varying needs! Take the glamour out of teen pregnancy and demonstrate the realities of the real world to your students. You never have to worry if students neglected the manikin. Ready-or-Not Tot® uses set programs so the teacher always knows when the manikin requires care. Student response to the manikin's needs are easily checked using the template provided. Comes complete with one set of student keys, one set of teacher keys, reproducible parental consent form/permission slip, reproducible student response sheet, teacher correction template, diaper, 9V battery, and instructions. Visit 3bscientific.com for product detail and characteristics.



White Male 1017931
White Female 1017932
Black Male 1018137
Black Female 1018138

\$310.00 ea.



A

Mini Model Set: Pocket Uterus, Baby, and Pelvis (6 Pieces)

Fit childbirth education in your pocket! An exceptional teaching tool, this set helps to explain what happens during labor and birth. The 14 cm long baby has a detachable placenta/cord with amniotic sac. Pelvis and knitted uterus are proportioned to fit the baby. Includes receiving blanket and tote bag.

48 cm; 1.0 kg
1018407 \$87.00



B

A. Childhood Immunizations Folding Display

This informative and award winning folding display includes basic information about vaccines and explains why people should get them. Also provides information about 15 diseases that can be prevented by vaccinations.

147.3 x 57.2 cm opened.
3004688 \$118.00

B. Shaken Baby Syndrome Folding Display

Describing symptoms and ways to prevent shaken baby syndrome, this folding display is an ideal educational tool for parents and infant caregivers. Includes information about dealing with a baby who won't stop crying.

147.3 x 57.2 cm opened.
3004686 \$118.00

Shaken Baby Demonstration Model

An infant's vulnerability to shaken baby syndrome (SBS) is powerfully demonstrated with this model. The model's translucent head allows viewers to see how a baby's brain can be harmed. Also emphasizes the importance of supporting an infant's neck. Helps teach prevention of SBS, which can have devastating consequences including permanent brain damage, blindness, and death. SBS tear pad also available.

60 x 31.4 x 22.2 cm
1017928 \$212.00



TOBACCO EDUCATION



Empathy Lungs

The Empathy Lungs are unique in that they simulate first-hand the symptoms of shortness of breath and breathlessness common to COPD, Asthma, and Lung Cancer. When used correctly and for short periods of time (15-30 minutes) the simulator causes the wearer to physically experience strenuous, labored, and shallow breathing along with the accompanying fatigue, irritability, and emotional distress that comes with the feeling of not being able to get enough air. The Empathy Lungs measurably reduce the wearer's total lung capacity which can be seen by measuring their Peak Expiratory Flow rates with the included Peak Flow Meter.

Visit 3bscientific.com for more details.

3004889 \$795.00

The Consequences of Smoking 3D Display

Show the consequences of smoking on various organs of the body with life-sized, handpainted models. Each model is permanently mounted in a carrying-case display, and the accompanying text clearly communicates its health message in simple terms. Ideal for health fairs, schools, hospitals, smoking cessation programs, or the workplace.

71.1 x 69 cm opened.
1005580 \$413.00



Smoked Lung™

This realistic, 3D lung model lets viewers see just what cigarette smoking does to their lungs. When the top is opened a grayish-white fibroufeeling cancer is revealed. Made from BIOLIKE™ synthetic tissue, this model of a right lung with emphysema and cancer is excellent for individual and group education.

12.7 x 22.9 x 10.2 cm
3004653 \$156.00

Death of a Lung Easel Display

When a patient or student views realistic models of lung tissue affected by smoking, the impact is stranger than any words or photographs. These three handpainted models represent a normal lung, a lung with emphysema, and a lung with cancer. This unique, 3D display illustrates the dangers of smoking in a way viewers will never forget. Comes with protective felt cover.

23 x 30.5 cm
3004660 \$126.00



A. Mr. Dip Lip™

This one-of-a-kind product makes anyone question what dipping is really about. The mouth opens and closes from the rear, and flesh-like lips may be retracted to show the effects dipping can have on the inner lip, gums, and teeth.

15 x 13 x 15 cm; 0.2 kg
1005581 \$158.00

B. Mr. Gross Mouth

This hinged model of the teeth, flexible tongue and oral cavity shows the effects of smokeless tobacco. Mounted on base, supplied with a bottle of simulated tobacco juice.

15 x 20.3 x 10 cm
1005566 \$146.00

C. A Year's Worth of Tar

This graphic, sealed exhibit, containing a pack of cigarettes and cigarette butts submerged in gooey tar, represents the amount of carcinogenic liquid a one-pack-a-day smoker puts into his/her lungs over the course of year.

13 x 14 x 7 cm
1005578 \$72.00



Smoker's Foul Mouth Display

Graphically displaying what cigarette smoking can do to the mouth, this model details a variety of harmful effects, including gum disease, tooth decay, lip cancer, and more. This unique, hinged model includes two removable tongues. One tongue depicts a hairy tongue in, and the other portrays leukoplakia and tongue cancer. Mouth is mounted on a handpainted model of the lit end of a cigarette. Comes with simulated cigarette that can be used as a pointer. 67.3 x 33 x 13.3 cm
3004757 \$175.00

A. Effects & Hazards of Smoking Display

This folding display helps viewers understand the initial and long-term effects of nicotine and smoke by-products on the human body. Comes with 25 reorderable minitexts. 147.3 x 56 cm opened.
3004623 \$118.00

B. Effects & Hazards of Secondhand Smoke Display

This folding display points out that second-hand smoke puts nonsmokers at risk for developing a number of serious conditions and diseases. Comes with 25 reorderable minitexts. 147.3 x 56 cm opened.
3004626 \$118.00

C. Smokeless Tobacco: Spit It Out Display

Smokeless tobacco is often first used by young males; this folding display targets teenagers specifically, using direct language and gripping images to expose the truth about inspit in tobacco. Eye-catching and made to last.
3004624 \$118.00

Carrying Case for Displays

(not shown)
 Fits all folding displays, holds up to 12 displays.
3004618 \$50.00

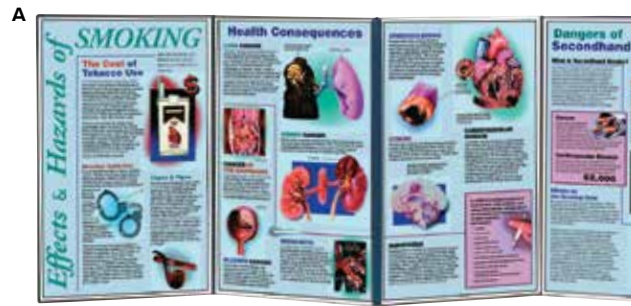

A Pack of Toxic Tar Display

Many people give little thought to the amount of dangerous tar found in cigarettes. This realistic display contains two removable cigarettes filled with goopy tar. The tar in these two cigarettes represents the amount of toxic tar that a smoker receives from smoking one pack of cigarettes.
3004760 \$40.00

Clem's Phlegm™

Graphically demonstrating one of the nasty consequences of smoking, this attention-getting sealed jar contains about 2 weeks of the phlegm that would be coughed up by a smoker with COPD. Great discussion starter for any anti-smoking lesson or program. 9.5 x 15.2 cm
1020792 \$76.00



Teeth in Tobacco Juice

Sealed in a plastic jar of simulated tobacco juice containing tobacco flakes, this model of damaged and decayed teeth and gums sends a clear message about the effects of smokeless tobacco use. 9.5 x 15.2 cm
3004648 \$80.00



Tainted Blood: Smokers' Blood Revealed™ Display

Designed to look like a cigarette on one side and an artery on the other, this colorful display graphically explains the damage smoking causes in a smoker's bloodstream. The artery in the model shows how smoking causes carbon monoxide to inchoke in out oxygen in the bloodstream and contains models reflecting the poisons that flow through the bloodstream of a smoker. Plaque buildup caused by smoking is depicted on the sides of the model. Display includes a tent card that explains each of the aspects of the model and provides further information about the consequences of smoking. Model is 25.4 x 7.6 x 6.4 cm. Tent card is two-sided and 21.6 x 27.9 cm.
3004712 \$115.00



➤ **Great teaching aid for teachers and students!**



Ready or Not Tots® - Drug Affected Training Babies

The FIRST manikin to simulate a baby's varying needs is even better! This manikin is both a drug prevention baby and a general teen pregnancy prevention baby with four programs! Comes complete with one set of student keys, one set of teacher keys, reproducible parental consent form/permission slip, reproducible student response sheet, teacher correction template, diaper, 9V battery, and instructions. See online for additional features.

Features include:

- Differentiate between Shaken Baby Syndrome and other types of abuse
- Offers three different tending programs typical of most babies
- Fourth tending program simulates the more annoying cry of a drug- or alcohol-affected baby
- Alerts teacher to a student's abuse, panic, or tampering with the control box
- Newborn-size doll represents a baby of a teen mom – 2.5 kg, 50.8 cm long
- Demo option included

| | | |
|---------------------|----------------|---------------------|
| White Male | 3004304 | |
| White Female | 3004305 | |
| Black Male | 3004306 | \$385.00 ea. |
| Black Female | 3004307 | |

Effects of Smoking Activity Model

Give your students a firsthand view of how tar and other pollutants accumulate in the lungs during smoking. Simply place a lit cigarette that you provide in the mouth of the inSmoking Man in and draw smoke into his lungs in using the syringe pump included. The results will amaze you as you watch his lungs start to darken after only a few short puffs! Includes detailed teacher and student guides that provide extensive background information on the dangers of smoking.

13 x 10 x 23 cm
1005932 \$90.95



Smoker Model

This small hand-held model actually smokes a cigarette and collects its tars and nicotine on a photo of a real chest X-ray of a lung cancer victim. Stained prints fit into plastic bags, keeping stains intact when they are passed around for closer inspection.

13 x 29 x 5.5 cm
1005577 \$66.00



Lou-Wheeze

Students get a shockingly accurate picture of smoking-related lung damage with this interactive display. Lou-Wheeze has two flexible latex lung models. One representing a healthy lung, the other showing the damage done by emphysema and cancer. Comes with bellows pump and instructions.

43 x 58.5 cm
1020790 \$265.00



Smokey Sue Smokes For Two

As Smokey Sue smokes a cigarette, tar collects around the lifelike model of a 7-month-old fetus, graphically showing the pollutants that can reach a developing baby. Jar and fetus are easy to clean. 7 x 35.5 x 12.7 cm

1020793 \$176.00

Smokey Sue – The Dangers of Smoking

Smokey Sue dramatically demonstrates the quantity of tar collected in the lungs when one single cigarette is smoked. The tar, normally inhaled directly into the lung, is collected in a transparent tube, and thus shows the quantity of tar which reaches the lung with each cigarette very clearly. Delivered with stand, 3 collection tubes, and carrying bag. 15 x 35.5 x 16.5 cm; 115 kg

1005565 \$144.00



SUBSTANCE ABUSE



Drug Identification Guide

This large display uses realistic facsimiles to show today's most commonly abused drugs. Handpainted, 3D models are enclosed behind Plexiglas. Stands on a tabletop for easy display. Comes with an informative, reproducible handout.

81.3 x 61 cm
3004644 \$478.00



A. Substance Abuse ID Guide Flip Chart

One of the biggest problems in dealing with drugs and alcohol is being able to recognize signs of abuse. This material can be used to teach employees, families, and students about different types of drugs and the symptoms of their use. Covers alcohol, inhalants, narcotics, depressants, stimulants, cocaine, hallucinogens, and marijuana. Flip chart features presenter's notes on reverse panels.

30.5 x 43.2 cm
3004714 \$100.00

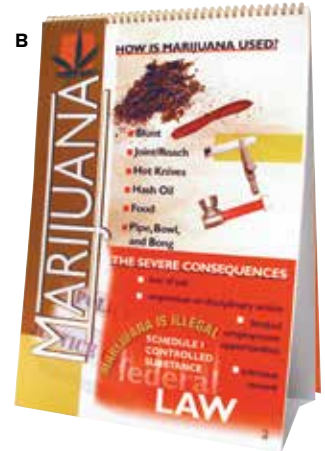

B. Marijuana Flip Chart

This flip chart describes marijuana, reveals its harmful effects, and lists possible signs of marijuana use. Perfect for teaching that marijuana is not a harmless drug. Flip chart features presenter's notes on reverse panels.

30.5 x 43.2 cm
1020788 \$100.00



Alcohol Dependence

Detailed anatomy illustrations show the effects of alcohol on the organs of the human body. This thickly laminated anatomical chart is printed on premium glossy (200 g) UV resistant paper to ensure the chart does not get a faded yellow color over time. The poster comes with 2 sided lamination (125 micron, 5.0 Mil) and metal eyelets to make the chart easy to display.

50 x 67 cm
1001620 \$21.00

Meth Mouth: An Inside Look

Graphically depicting the grisly effects of methamphetamine abuse on the mouth, this display is ideal for organizations looking to give compelling reasons to stay away from meth. The 3D handpainted model shows consequences of meth use such as missing teeth, severely decayed teeth, broken teeth, receding gums, and more. Also includes a tongue model with an ulcer. Informative text explains how meth harms both the mouth and the body and drives home the message that meth is a dangerous drug.

25.4 x 25.4 x 40.64 cm
3004646 \$217.00



➤ **Our Chart Section is Unmatched in Detail!**
 See pages 90-93 for Our Chart Selection



1001618 \$21.00
4006726 \$14.00



1001622 \$21.00
4006728 \$14.00

The Consequences of Drug Abuse 3D Display

This detailed display shows what actually happens to the body when drugs are abused. Life-size, hand-painted models of the body's organs are graphic and accurate. Brief descriptions make this educational tool ideal for health fairs and schools.

71.1 x 69 cm opened.
1005583 \$413.00

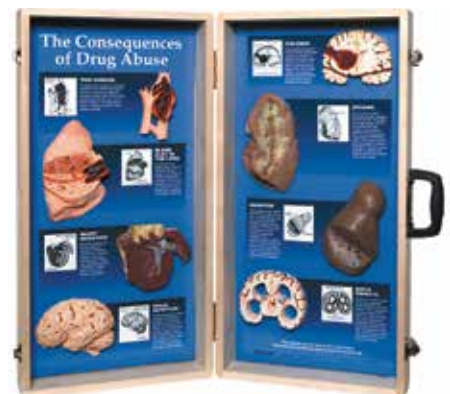



Drug Education Guide

Ideal for educating parents and youth, this 3D, plexiglacovered display identifies basic drug groups and gives the medical and slang names, medical uses, and possible effects of use for many common drugs. Features accurate, handpainted drug facsimiles. Comes with informative, reproducible handout.

61 x 61 cm
3004765 \$413.00



Wheel of Misfortune Game

An excellent tool for starting discussions on drug abuse, this game includes questions about the identification and effects of various substances. Multiple-choice questions that call for value judgements are also included. Contains questions designed for use with grades 1-5 and 6-12.

52.1 x 71.1 cm
1020789 \$154.00



Drug Awareness Guide Display

This colorful display shows eight categories of abused substances and various examples of each type. Sixty-six substances and their paraphernalia are pictured and crossreferenced with their street names, uses, and effects. This invaluable drug-education tool is framed. Comes with its own built-in easel and informative, reproducible handout.

W43244 \$110.00



Drunk Busters Goggles

These unique goggles simulate the effects that alcohol consumption has on the body including: visual distortion, alteration of depth and distance perception, reduction of peripheral vision and double vision.

Available in four different versions. All goggles include a cloth carrying bag and an Instructor's Guide.

Each and every goggle is backed by a 3-year warranty.

| | | | |
|------------------------|--------------------|----------------|----------------|
| Black Strap BAC | 0.08 - 0.15 | 3006496 | \$99.00 |
| Blue Strap BAC | 0.06 - 0.08 | 3006497 | \$99.00 |
| Green Strap BAC | 0.04 - 0.06 | 3006498 | \$99.00 |
| Red Strap BAC | 0.15 - 0.25 | 3006499 | \$99.00 |

Drunk & Dangerous Glasses with Case

These glasses will give any alcohol education program an added dimension, allowing the instructor to deliver a powerful message quickly and clearly. Drinking and driving can be a deadly combination. Because the glasses' simulation of drunkenness is so real and intense, wearers can't help but be struck by the reality that alcohol really does make driving dangerous.

Supplied with case.
1005576 \$155.00



Substance Abuse Identification Kit

Informative and eye-catching, this 3D display identifies several dangerous drugs and lists short- and long-term effects of drug abuse. Features handpainted models and a durable Plexiglas cover. Includes two stand-alone panels and an informative, reproducible handout.

Case is 73.7 x 50.8 cm opened.
 Stand-alone panels are 30.5 x 44.5 cm each.
3004717 \$394.00



Effects and Hazards of Substance Abuse Folding Display

Outlining both the physical and social consequences of substance abuse, this folding display offers an excellent overview of a number of dangerous substances, including narcotics, inhalants, club drugs, and more. Also includes information on getting help for a substance abuse problem.

147.3 x 57.2 cm
3004716 \$118.00

NUTRITION



Vat of Fat

Explaining how calorie intake translates into weight gain is simplified with this graphic and informative display. The plastic jar contains approx. 0.45 kg of goopy simulated fat, which represents the amount of weight a person could gain in one week by consuming an extra 500 calories each day. Information on the back of the jar shows how much weight a person could gain in one year as a result of excess calories. 12.7 x 16.5 cm
1018309 \$79.00

Rolls of Fat

One in four Americans is obese, and more than half of all Americans are overweight. Use these models as a dynamic presentation about obesity and the distribution of fat. These models have the look, feel, weight and approximate volume of fat. Students can wrap these rolls around their waistslines for a demonstration of how fat accumulates. Use in conjunction with the Body Muscle Replicas (W44657 and W44658) to compare the size of fat versus the size of muscle.

0.45 kg roll: 29.9 x 7.6 x 2.5 cm / 2.27 kg roll: 73.7 x 14 x 2.5 cm

2.27 kg/0.45 kg Set 3004657 \$121.00



Complete MyPlate Kit

This kit combines five plates, the display rack, and the food kit for your complete MyPlate educational teaching kit. The 42-piece food kit includes grains, protein, fruit and vegetables Life/form® food replicas. With the included durable plastic plates featuring the USDA healthy eating graphic, you can easily explain the principles of well balanced meals. Your students and patients can fill the plate and learn what to do differently.

1018318 \$489.50

➤ **More MyPlate products for healthy eating featuring the USDA healthy eating graphic**

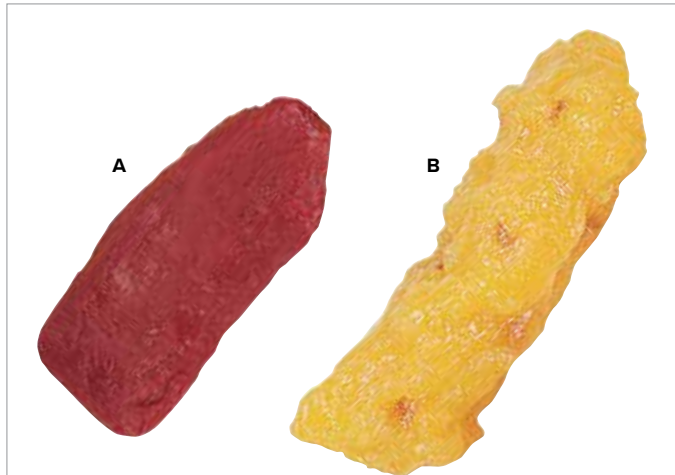

A. Body Muscle Replicas

Designed to show the muscle configuration developed through exercise. Motivate your students to exercise regularly. Made of long-lasting vinyl plastic. All replicas represent accurate weight and volume.

2.27 kg 3004381 \$82.95

0.45 kg 3004380 \$28.95

B. Body Fat Replicas

A shocking but highly motivating attention getter. Made of soft, pliable, long-lasting vinyl plastic, the replicas have a profound, memorable effect when passed around among the audience.

All replicas represent accurate weight and volume.

2.27 kg 3004379 \$89.95

0.45 kg 3004378 \$31.95

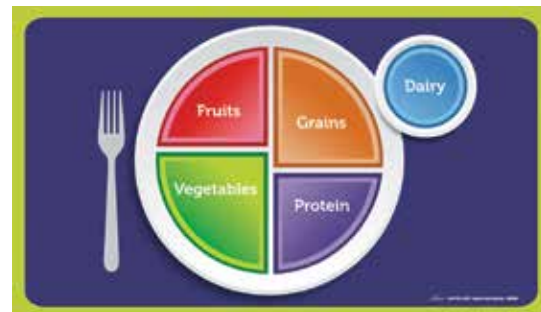

MyPlate Cling Place Mats

These plastic place mats, which are also food clings, are an engaging nutrition teaching tool. Participants can easily create many suggested meals using these guidelines. Set of five place mats with easy cling and peel material.

48.5 x 28 cm

1018317 \$29.95

MyPlate Plate

Also available individually! Made of FDA approved ABS plastic safe for food use. Dishwasher safe, not recommended for microwave oven.

Outside diameter 27.5 cm.

1018316 \$10.95

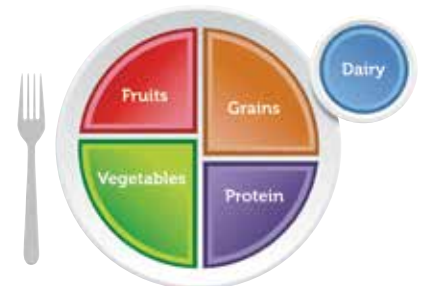



The Consequences of Obesity 3D Display

This display uses life-size, hand-painted models to explain the dangers of obesity. Models are permanently mounted in a sturdy wooden case and are accompanied by text that clearly describes each condition. Ideal for health fairs, schools, or any nutrition education event.

71.1 x 68.6 cm opened.
3004616 \$403.00



Consequences of an Inactive Lifestyle 3D Display

This 3D display graphically shows many of the negative health consequences of an inactive lifestyle. Each permanently mounted, handpainted model has a brief description of the consequences it represents. Display is contained within its own sturdy carrying case.

71.1 x 68.6 cm opened.
1018300 \$403.00



Benefits of Physical Activity 3D Display

The real benefits of physical activity are easy to see with this interactive 3D display. Its four swiveling panels show rewards of an active lifestyle on one side (strong muscles, health arteries, healthy joints, and reduced body fat) contrasted with consequences of a sedentary lifestyle on the other side (muscle loss, diseased arteries, osteoarthritis, and increased body fat). Can be used as a tabletop display or mounted on a wall.

67.3 x 33 x 13.3 cm
1018301 \$339.00



Heart Disease Risk Factors Display

Learning about the risk factors for heart disease is made easy with this fun, interactive display. Participants slide the arrow up the scale to add up their risk for each factor listed on the display. Both controllable and non-controllable risk factors are included.

52.1 x 71.1 cm
3004737 \$118.00

Healthy Eating Out Flip Chart

By outlining ways to make healthy choices from restaurant menus, this flip chart helps to solve the eating-out dilemma in each page and explains how different food preparation methods affect nutritional value. Flip chart features presenter's notes on reverse panels.

Flip chart is 6 panels.
 30.5 x 43.2 cm
1018408 \$100.00



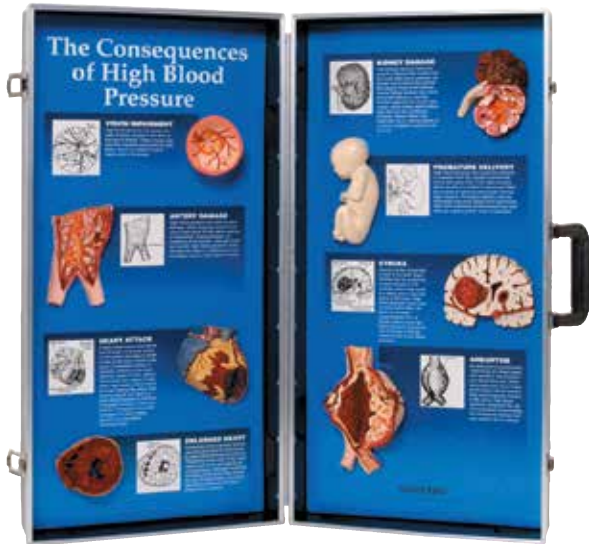

Consequences of High Blood Pressure

Life-size, three-dimensional, hand-painted models illustrate the various organs that can be affected by high blood pressure. Great for health fairs and health-education promotions. Contained in a convenient, sturdy wooden carrying case.

71.1 x 68.6 cm opened.
1018277 \$403.00



Arteriosclerosis Model, with Cross Section of Artery

Changes in the blood vessels due to arteriosclerosis can be quickly and easily explained with this model. A horizontally dissected artery fork is depicted with arteriosclerotic changes in four different stages, from slightly sedimented to a completely clogged vessel.

Mounted on base. 15 cm; 0.2 kg
1000278 \$82.00



Occluded Artery Model

The potentially deadly effects of high cholesterol are demonstrated with this persuasive model. The tube represents an artery constricted by plaque, which forms on artery walls when there is excess cholesterol in the blood. When the model is turned over, the blood in the artery slows or stops completely. An excellent tool for explaining the importance of keeping cholesterol under control.

7 x 17.5 cm
1018304 \$82.00

Why Blood Pressure Checks Can Save Your Life

Patients and students learn the importance of blood pressure checks when they see these handpainted, 3D models of arteries and this cross section of the brain. Demonstrates the way high blood pressure can silently lead to heart attacks or strokes. Comes with protective felt cover.

22.9 x 30.5 cm
1018289 \$126.00



Death of an Artery Easel Display

These handpainted, cross-sectional, 3D models of arteries show patients and students the various stages of plaque build up. The interior size of each vessel diminishes, making it easy to explain a process that can eventually result in death. Comes with protective felt cover.

22.9 x 30.5 cm
1018290 \$126.00

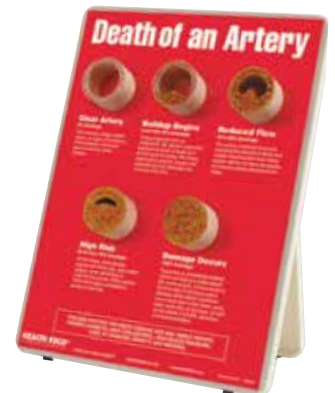

Cholesterol Flip Chart

Many people do not know what steps they can take to maintain healthy cholesterol levels.

This flip chart explains the facts about good and bad cholesterol and the health risks associated with high cholesterol levels. Features presenter's notes on reverse panels. Flip chart is 6 panels.

30.5 x 43.2 cm
1018306 \$100.00



Blood Cholesterol & Triglycerides Packet

The need for a healthy diet is emphasized by the four blood viscosity samples in this pack. The samples show the exaggerated differences seen when analyzing blood serum for lipid and glucose concentrations.

1018315 \$19.95

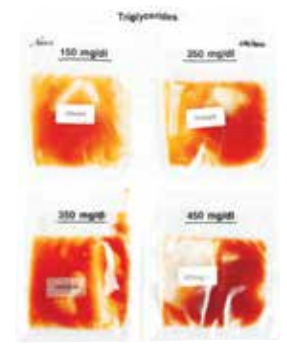

DIABETES



Four Piece Diabetes Model

Four piece model indicating structures and organs with vascular effects due to diabetes. Includes sectioned model of Bowman's capsule (kidney), artery, nerve, and eye (posterior section). Full model size without handle: 8.9 x 5.1 x 5.1 cm Handle size: 12.7 x 5.1 cm
1019574 \$59.10

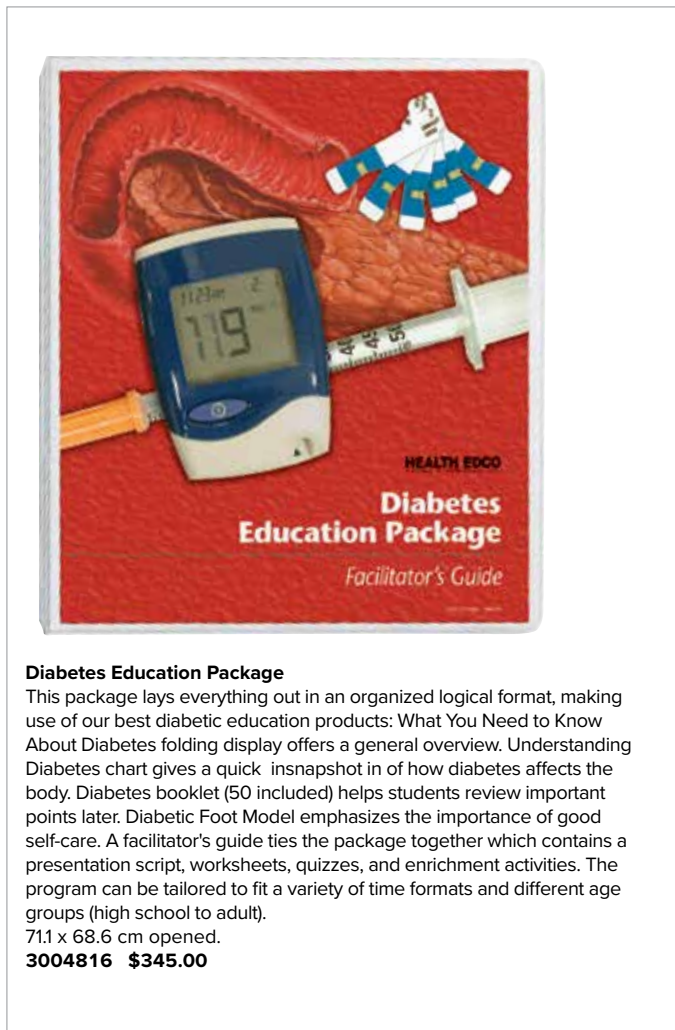
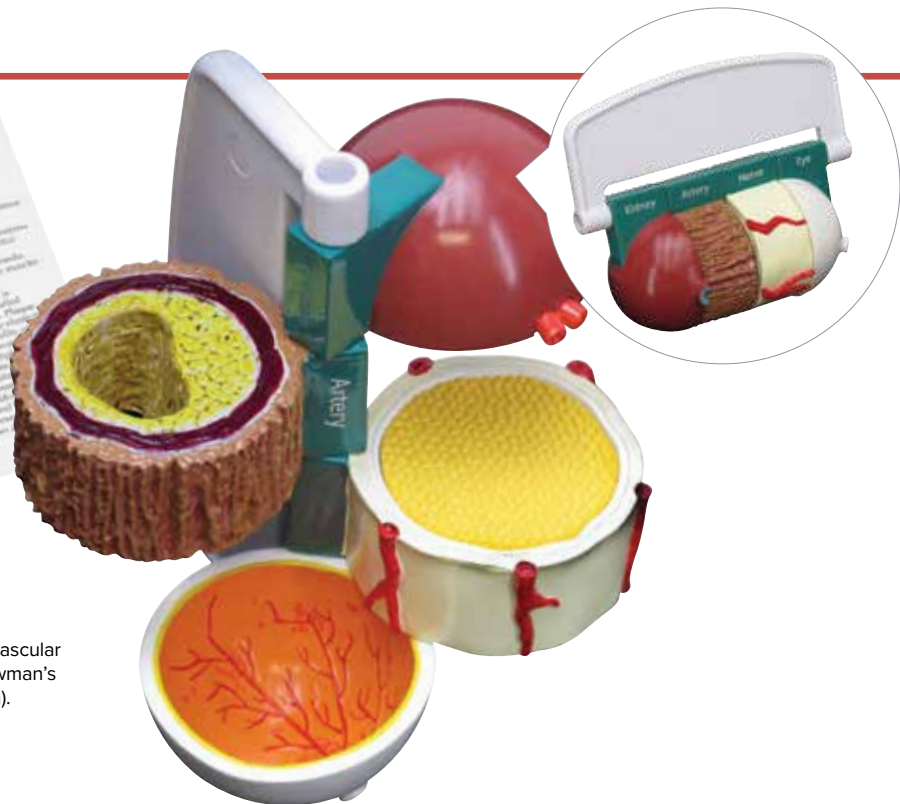

Diabetes Education Package

This package lays everything out in an organized logical format, making use of our best diabetic education products: What You Need to Know About Diabetes folding display offers a general overview. Understanding Diabetes chart gives a quick insnapshot in of how diabetes affects the body. Diabetes booklet (50 included) helps students review important points later. Diabetic Foot Model emphasizes the importance of good self-care. A facilitator's guide ties the package together which contains a presentation script, worksheets, quizzes, and enrichment activities. The program can be tailored to fit a variety of time formats and different age groups (high school to adult).
 71.1 x 68.6 cm opened.
3004816 \$345.00

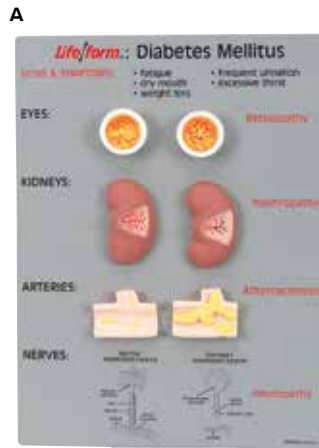

A. Life/form® Diabetes Mellitus Teaching Kit

Explain the signs, symptoms, and health problems associated with diabetes using this 3D display. Also included in the kit is a 4-page booklet. Subjects include diagnosis, treatment, complications, eyes, kidneys, arteries, and nerves. The model is mounted on a sturdy, 22.9 x 30.5 cm plaque with wire stand for easy desk or tabletop display. Hand painted.
1020039 \$146.50

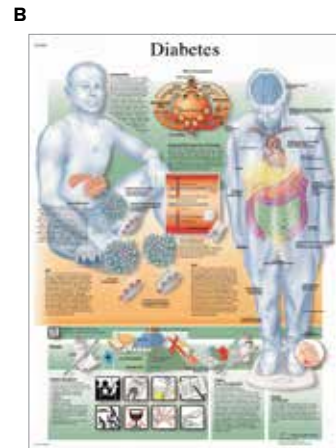

B. Diabetes Mellitus Chart

This anatomical chart details the disease diabetes, its causes and effects as well as treatments for disease. A great diabetes teaching tool for a classroom or doctors office. Laminated and printed on premium glossy. (200g) paper. 51 x 66 cm
1001554 \$21.00
4006694 \$14.00



➤ **Graphic, accurate information in a display case!**

Consequences of Diabetes Display

Many diabetics don't understand the often-horrific consequences of failing to properly manage their condition. Arresting models depicting a heart attack, a stroke, and infected gums motivate viewers to take charge of their health. Display is contained within its own carrying case.

71.1 x 68.6 cm opened.

1020794 \$403.00

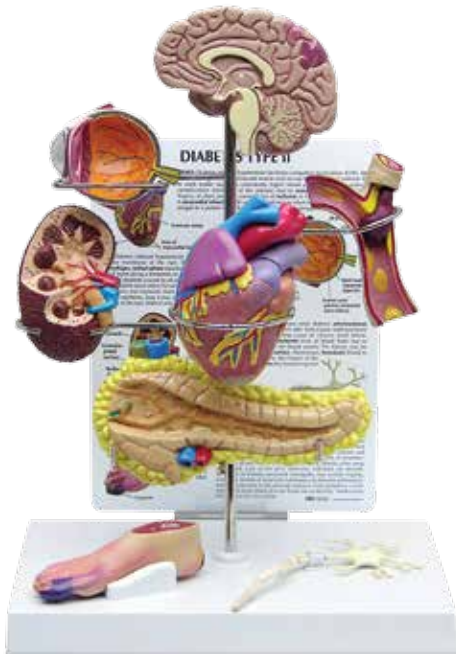

Type II Diabetes Set

Model displays miniature brain, eye, heart, kidney, artery, pancreas, neuron, and foot models. Education card illustrates effects associated with Type II Diabetes: stroke, ocular pathology, hypertensive heart disease, hardening of the kidney, hardening of the arteries, insulin resistance, neuropathy, and foot ulcerations. Model display stands 25.4 cm tall. Models are reduced size.

1019573 \$159.50

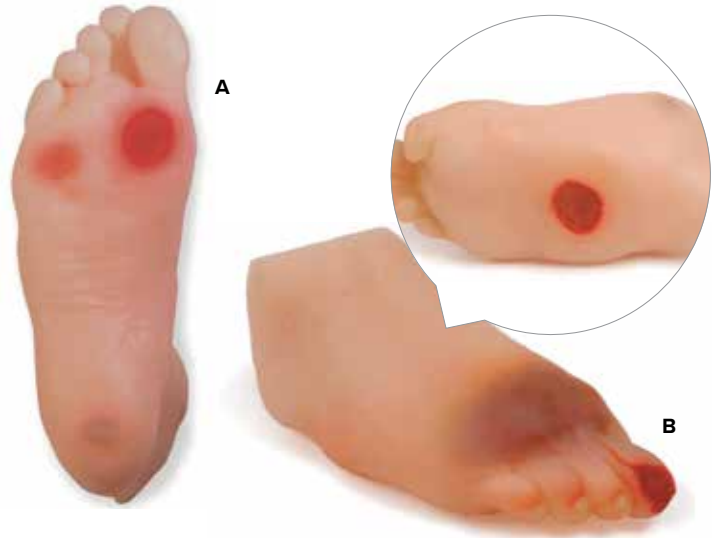

A. Diabetic Foot Model

This life-size diabetic foot model can be used for both patient education and student training. Made from lifelike BIOLIKE™ material, the model contains three ulcers in various stages of development as well as the features commonly associated with diabetes. A graphic reminder of the importance of proper foot care. Comes with carrying case and instruction card.

9 x 24.1 x 10.2 cm

1017936 \$129.00

B. Severe Diabetic Foot Model

This life-size, BIOLIKE™ replica complements the original Diabetic Foot Model by showing additional, more severe consequences of diabetes, including an amputated toe, Charcot foot deformity, and severe infection and gangrene. Comes with a carrying case and instruction card.

9.5 x 22.9 x 11.4 cm

1017937 \$129.00



Diabetic Injection Practice Kit

Made from realistic BIOLIKE™ material, these teaching models facilitate technique practice on both an injection skin and a finger stick apparatus. The skin model may be strapped to the user's arm or leg to simulate a needle injection site, and the finger stick model may be held by the attached grip for lancet practice. Both can be punctured repeatedly.

Replacement skin for the skin model and replacement finger are available.

Comes with powder and carrying case. Skin model is

15.2 x 11.4 x 3.8 cm, and finger stick model is 2.5 x 11.4 x 2.5 cm.

1018139 \$51.00



CAREER TECH

Reliable simulators for basic, intermediate, and advanced clinical skills training.

- Basic Life Support
- Advanced Life Support
- Airway Management
- Advanced Trauma Life Support
- Rescue Training
- Choking / CPR
- Injection / Venipuncture
- Bandaging / Suturing
- Blood Pressure Training
- Patient Care
- ALS Manikins



Fast and effective CPR training

- + Track and analyze CPR performance with the included tablet
- + Easy to set up with magnetic connections – no extra tools necessary
- + Very Hygienic as it uses a separate air chamber system
- + Extremely durable material that is easy to clean
- + Fast cleaning process for efficient time management
- + Includes tablet and software for measuring training success with PDF view

Track and analyze CPR performance with the 3B Scientific® CPRLillyPRO™ simulator.

3B Scientific® Qualified CPR Training with CPRLillyPRO™

CPRLillyPRO™ – The best choice for your professional CPR training courses. All relevant CPR training parameters can be monitored comfortably and easily via the tablet provided. Trainers and trainees will very quickly attain the chosen training target via the direct feedback feature.

Displayed training parameters:

- Compression depth
- Compression frequency
- Hand position
- Head tilt
- Respiration volume/speed (combined)
- Respiration pressure

The face masks can be changed, and are easy to clean. The software can control the carotid pulse and the eye movements. CPRLillyPRO™ can react by opening the eyes when spoken to by the trainee. The correct head tilt, individual carotid pulse, and the moveable jaw to demonstrate the jaw thrust manoeuvre, provide realistic scenarios. CPR training with the CPRLillyPRO™ complies with the latest AHA and ERC guidelines. Comes with carrying bag, 5 lower face masks (including teeth), 25 throat bags, 1 tracksuit top, 1 Android tablet PC, charger and plug adaptor.

78 x 39 x 26 cm; 9 kg

Light Skin 1017773 \$2,058.00

Dark Skin 1017775 \$2,058.00



No tools are necessary as it has strong magnetic connections.





3B Scientific® CPRLilly™

CPRLilly™ is the basic version for all CPR training courses. This training manikin is hygienic, and will operate economically for a long time as it uses disposable throat airbags and has a separate air chamber system. The face masks can be changed, and are easy to clean. The carotid pulse and the eye movements can be controlled separately by the instructor. When the correct compression depth is reached, a tone will sound. CPRLilly™ can react by opening the eyes, this is controlled manually. The correct head tilt, individual carotid pulse, and the moveable jaw to demonstrate the jaw thrust manoeuvre, provide realistic scenarios. CPR training with CPRLilly™ complies with the latest AHA (American Heart Association) and ERC (European Resuscitation Council) CPR guidelines.

Comes with carrying bag, 5 lower face masks (including teeth), 25 throat bags and 1 tracksuit top.

78 x 39 x 26 cm; 8 kg

Light Skin 1017772 \$1,080.00

Dark Skin 1017774 \$1,080.00

➤ Give us a call at 1.866.448.5846 to customize your own CPR kit!



| Replacement Parts for CPRLilly™ Simulators | Item No. | Price |
|--|----------|----------|
| Upper Face Mask Light (1x) | 1017737 | \$38.00 |
| Upper Face Mask dark (1x) | 1017764 | \$36.00 |
| Resuscitator | 1013678 | \$98.00 |
| Lower Face Mask with Teeth Light (5x) | 1017738 | \$244.00 |
| Lower Face Mask with Teeth Dark (5x) | 1017765 | \$252.00 |
| Throat Bag (pack of 50) | 1017739 | \$44.00 |
| Throat Bag (pack of 100) | 1017743 | \$78.00 |
| Bag Clip | 1017748 | \$22.00 |
| Carrying Bag | 1017744 | \$94.00 |
| Disinfectant | 1013579 | \$36.00 |
| Lower Jaw | 1017749 | \$32.00 |
| Torso Skin Light | 1017747 | \$344.00 |
| Torso Skin Dark | 1017766 | \$344.00 |
| Eyes Light (pair) | 1017758 | \$94.00 |
| Eyes Dark (pair) | 1017767 | \$94.00 |
| Tracksuit Top | 1017746 | \$116.00 |
| Squeeze Ball (light blue) | 1017750 | \$40.00 |
| Squeeze Ball (white) | 1017751 | \$40.00 |
| Eye Rings (pair), Light | 1017759 | \$46.00 |
| Eye Rings (pair), Dark | 1017778 | \$46.00 |

➤ Reliable and economical

Basic Life Support Manikin BASICBilly™

BASICBilly™ was developed utilizing the results of extensive studies focussing on the depth and force of compression during cardiopulmonary resuscitation (CPR). It fulfills the latest guidelines from the AHA (American Heart Association) and ERC (European Resuscitation Council) on CPR and was designed with optimal force and compression values in mind.

2 in 1

BASICBilly™ is actually two manikins in one as it can be used as either an **adult** or a **child** (approx. 12 yrs.) CPR trainer. Just use the easy and interchangeable springs located in the back of the trainer to switch between the realistic depth feedback of either the adult (5cm) or child (4.5cm).

Included:

- 1 BLS simulator (torso) with spring for cardiac massage of adults
- 1 additional spring for cardiac massage of children (approximate age of 12)
- 5 lung bags, adult
- 5 lung bags, child
- 2 telescopic guides
- 1 additional face mask and inner head for hygienic artificial respiration
- 1 disinfectant solution
- 1 carrying bag

60,5 x 35,5 x 19 cm, 2.36 kg

Light Skin 1012793 \$280.00

Dark Skin 1017679 \$280.00



Features of BASICBilly™

- + Anatomically correct for realistic training
- + Hygienic to use with low priced disposable airways
- + Head is easy to tilt to prepare for mouth-to-mouth or mouth-to-nose resuscitation
- + Thorax raises as the lungs are ventilated
- + Developed and manufactured in Germany



Easy to switch between adult and child CPR setup



Act+Fast Rescue Choking Vest

Invaluable tool for CPR instructors to easily and effectively teach students the correct way to perform the Abdominal Thrust Maneuver (Heimlich) without using a manikin. When performed correctly, a foam plug shoots into the air, making teaching easy and learning fun. 10 foam plugs included.

Act+Fast Blue
1017938 \$129.00

Act+Fast Red
Features a Back Blow Pad for practicing ARC and ERC protocol.
1014589 \$139.00

Basic Buddy™ CPR Manikins

The one-piece, disposable lung/mouth protection system makes this manikin completely sanitary – there is no risk of cross contamination and no need to sanitise the manikins after use! Rugged carrying bags make transporting the lightweight Basic Buddy™ 5 and 10-Packs convenient (manikins fit into bags fully assembled).



Basic Buddy™
1 manikin, 10 lung/mouth protection bags, 1 insertion tool, instruction manual.
20 x 37 x 52 cm; 2.2 kg
1005637 \$94.50

Basic Buddy™ 10-Pack
10 manikins, 100 lung/mouth protection bags, 2 carrying bags, 10 lung insertion tools, 2 instruction manuals. 12 kg
1005635 \$795.00

Basic Buddy™ 5-Pack
5 manikins, 50 lung/mouth protection bags, 5 lung insertion tools, 1 carrying bag, instruction manual. 6 kg
1005636 \$439.00

Replacement parts:
100 ct Lung/Mouth Protection
1005638 \$42.00

5 Torso Carrying Bag
1005639 \$40.00

CPR / CHOKING



Jaw Thrust Brad

Jaw Thrust Brad utilizes simple moving-parts technology for the instruction of the jaw thrust maneuver. Unique to the industry is the function of ventilating the patient when the proper maneuver is done without tilting the head.

Features:

- Moveable jaw
 - Individual mouth piece
 - Sanitary one-way bag allows multiple users while requiring a single replacement at end of day
 - Removable chest plate for adolescent and adult CPR
 - Rugged vinyl skin and long-lasting foam filling
- Includes kneeling pads and carry bag.
71 x 46 x 25 cm

1013162 \$239.70

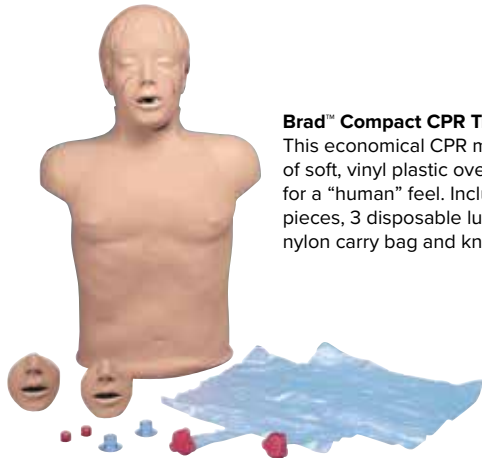

Brad™ Compact CPR Training Torso

This economical CPR manikin is constructed of soft, vinyl plastic over polyurethane foam for a "human" feel. Includes 3 mouth/nose pieces, 3 disposable lung/airway systems, nylon carry bag and kneeling pads.

Features:

- Longer torso for realistic abdominal thrusts
 - Realistic head tilt and chin lift for opening airway
 - Easy to manipulate and realistically simulate airway obstruction or choking situations
 - User-friendly, low maintenance lung/airway design
- 65 x 38 x 22 cm, 5.4 kg

1005753 \$221.40

Replacement parts:

| | | |
|--------------------------------|----------------|----------------|
| Ribcage | 1013244 | \$31.70 |
| 24 Adult Airway Systems | 1005740 | \$65.30 |
| 10 Mouth/Nose Pieces | 1005741 | \$52.10 |



A. Family & Friends CPR Anytime

Now anyone can learn the life saving skill of CPR, in a convenient and budget friendly manner. The self-directed learning program comes complete with a mini Anne CPR Training Manikin, CPR Skills Practice DVD, 2 Pocket Reminder Cards (One Choking and Child CPR Pocket Reminder Card and One Adult CPR and AED with hands Only Pocket Reminder Card), Mini Anne Spare Lung, Manikin Wipes (2), and Directions for Use printed inside the box.

| | | |
|-------------------|----------------|----------------|
| Light Skin | 1018415 | \$38.50 |
| Dark Skin | 1018416 | \$38.50 |

B. Infant CPR Anytime

Parents can now learn the life saving skill of Infant CPR and relief of choking in less than 22 minutes. With this new self-directed learning program, parents, grandparents and others who are responsible for the care and safety of an infant can learn these lifesaving skills and be prepared to respond during the first few minutes of a life threatening emergency. Perfect for hospital maternity wards, churches, and local community centers for hosting training sessions.

| | | |
|-------------------|----------------|----------------|
| Light Skin | 1018417 | \$38.50 |
|-------------------|----------------|----------------|



Cardiac Emergency

In a cardiac emergency it is important to quickly implement lifesaving steps to help the victim. This poster reinforces the basic steps to follow in a cardiac emergency.

50 x 67 cm (20 x 26")

1018419 \$11.45

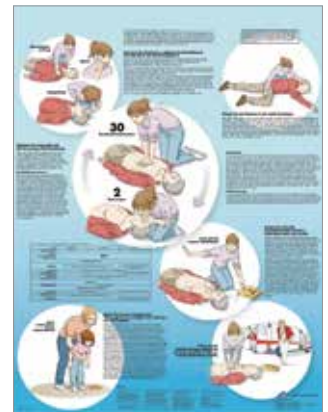

Basic Life Support Chart

50 x 67 cm (20 x 26")

| | |
|----------------|----------------|
| 1001616 | \$21.00 |
| 4006725 | \$14.00 |

► Extremely realistic haptic feedback

Epidural and Spinal Injection Trainer

Train the localisation of the epidural space without ultrasound to administer epidural and spinal injections. You can easily adjust the trainer to simulate different pathologies. The training with realistic haptic feedback and correct anatomical landmarks is the basis for a successful preparation for real-life cases.

Delivered fully assembled. All usual materials can be used, including disinfectant, plasters and wound dressing. Includes 1 LOR kit and 1 skin pad.

45 x 35 x 24 cm; 3 kg

1017891 \$1,723.00

Training features:

- Realistic anatomical landmarks for assessing the correct insertion point
- **Loss of resistance (LOR)** syringe technique through realistic haptic feedback
- **Hanging drop** method: the negative pressure in the fluid filled spinal canal can easily be adjusted
- An epidural catheter can be inserted into the epidural space
- Spinal anaesthesia training with realistic resistance of the dura and arachnoid mater with or without a cannula

About the trainer:

- Developed in Germany in close co-operation with epidural anaesthesia specialists
- Simulates the anatomy of a standard patient (young adult between 20-30 years old)
- Intuitive to handle, continuously adjustable fluid pressure
- Easy to clean: filled with water (closed system) to simulate spinal fluid
- Sturdy construction, all parts are integrated and latched
- Can also be used in lateral position, suction cups ensure steady positioning on the table

Low operating costs:

With the use of high-quality, hard-wearing materials, only a few parts need to be replaced periodically.

Self-sealing material for repeated use

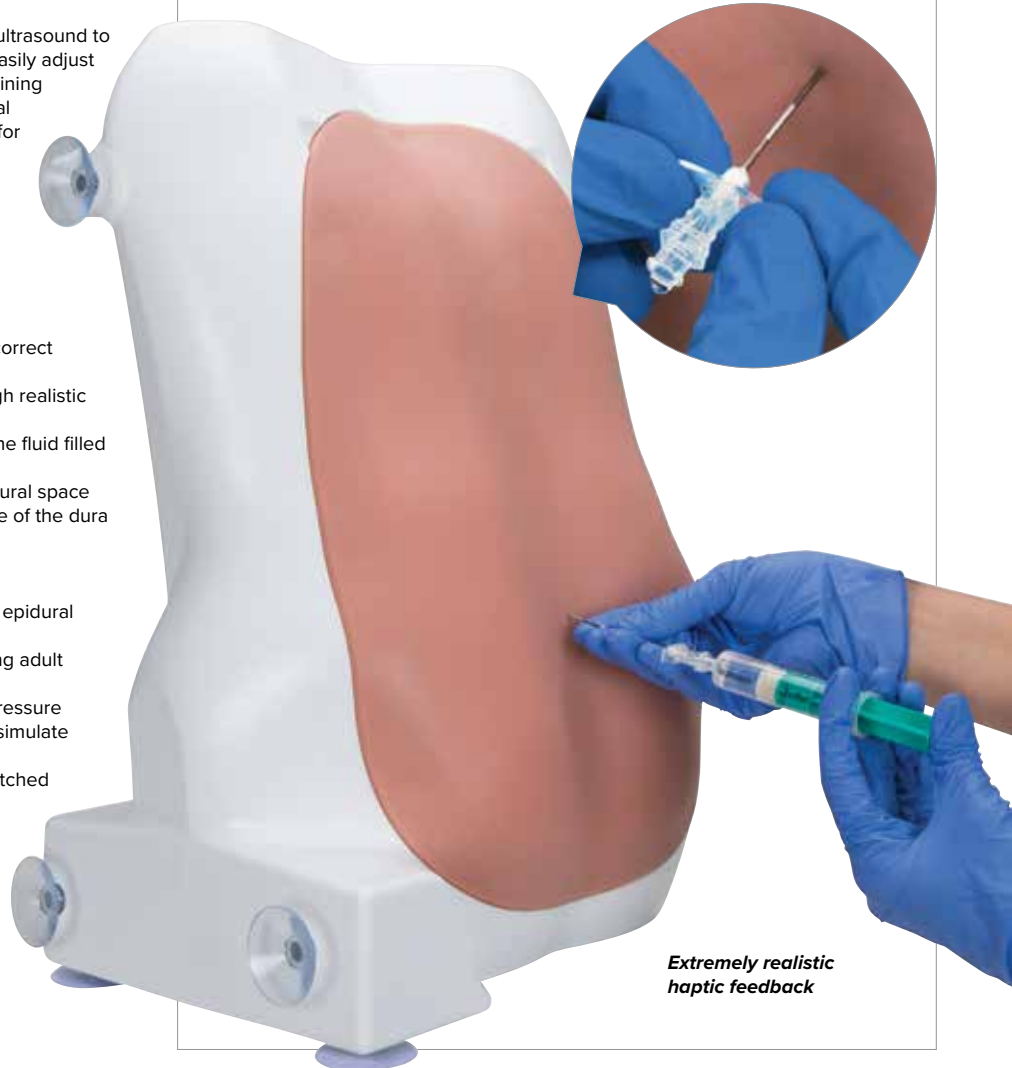

Extremely realistic haptic feedback



Continuously adjustable fluid pressure system on the backside

Sturdy, non-slip construction, easy to set up



| Consumables | Item No. | Price |
|--------------------------|----------|----------|
| Replacement LOR kit | 1017893 | \$367.00 |
| Replacement skin | 1017892 | \$111.00 |
| Carry bag (not included) | 1018079 | \$33.75 |



> NEW

I.V. Injection Arm

This injection arm, made of 3B Scientific® SKINlike™ silicone allows realistic, hands-on training to develop competence in medical staff. The material used is of the highest quality, stain resistant and easy-to-clean. Changing the skin and tubing system is easy and only takes a few minutes.

The simulator is ideal for practising:

- Intravenous injections
- Correct puncture of peripheral veins for blood sampling (basilic vein, cephalic vein, median cubital vein, dorsal venous rete of hand)
- Positioning of a butterfly catheter
- Delivered with stand, artificial blood, 2 replacement tubing systems, plastic bottle, syringe and deluxe storage carton.

74 x 19 x 14 cm; 2.8 kg

1021418 \$647.00

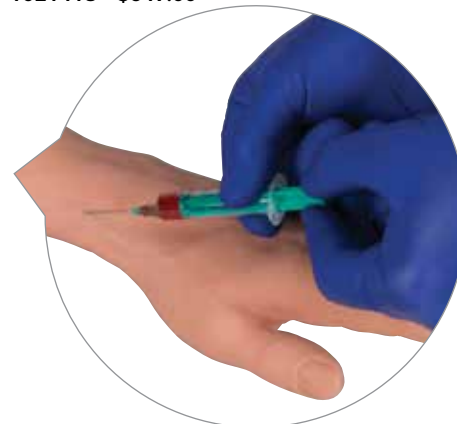

| Consumables | Item No. | Price |
|-------------------------------------|----------|----------|
| Spare Tube Systems, 3 items | 1021427 | \$125.00 |
| Spare Skin | 1021426 | \$320.00 |
| Artificial Blood Concentrate, 250ml | 1021251 | \$37.00 |
| Update kit infusion system | 1021423 | \$155.00 |

> Intramuscular injection can be practised realistically without a real patient – with both audio and visual feedback!

> The perfect volunteers to practise I.M. injections



I.M. Injection Simulators

These high quality simulators are the ideal way to teach proper I.M. injection techniques. Strap it onto the upper leg, upper right arm or the buttocks to locate all necessary intramuscular injection sites. Operates on AA batteries.

- Both audio and visual feedback
- Use for training and performance evaluation
- Includes all important anatomical palpable landmarks
- Life-like silicone skin is extremely durable, can quickly be exchanged
- Robust and easy to clean

| | | |
|---------------------|----------------|-------------------|
| A. Upper Arm | 1009840 | \$1,335.00 |
| B. Upper Leg | 1000511 | \$1,737.00 |
| C. Buttock | 1000514 | \$1,737.00 |

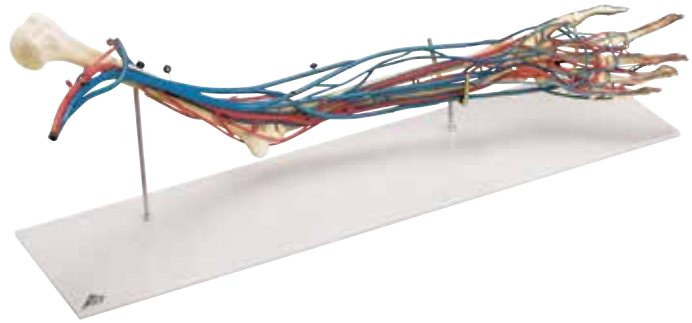

Vascular Arm

This life-size model provides a complete understanding of the circulatory system of the arm and hand. An excellent teaching aid for venipuncture training. Modeled in a semiflexed position with the brachial, radial, and ulnar arteries and accompanying veins with their radicals shown. The complete circulatory system of the hand is shown on both palmar and dorsal surfaces. Comparative sizes of the various blood vessels are clearly indicated and facilitate the study of the blood circulation in the arm. Mounted on a stand with key card. 4.5 lbs

1005109 \$702.00

Life/form® Portable IV Arm and Hand Trainers

The economical Life/form® Portable IV Training Arm and Hand combine realism, fine detail, and lightweight convenience in a single trainer. These self-contained trainers are packaged in a plastic case that can be converted into a work station. Trainers include everything you will need to begin training and practicing IV skills. Constructed of soft material with life-like veins in the skin surface that are visible and palpable, making it possible to practice venipuncture at any of the common sites. The characteristic inpop in can be felt as the needle penetrates the vein and a realistic flashback will be observed when the needle has been accurately inserted. These trainers are the ideal way to teach venipuncture techniques including starting IVs and introducing Over the Needle IV catheters. Hundreds of injections may be performed. Included with each of the trainers are two IV bags, packet of blood powder and spoon, fluid supply stand, two pinch clamps, 3 cc syringe, 12 cc syringe, 12 gauge needle, a winged infusion set, and a plastic clamshell case to store and transport the trainers and components. 1.02 kg

- A. IV Hand Light Skin 1017958 \$200.00**
- IV Hand Dark Skin 1017959 \$200.00**

- B. IV Arm Light Skin 1017960 \$200.00**
- IV Hand Dark Skin 1017961 \$200.00**



➤ Incredibly realistic with extreme attention to detail!



I.V. Injection Hand

An incredibly realistic hand with extreme attention to detail, right down to the fingerprints. Students have the opportunity to not only practice injection but to develop important manipulation skills provided by the flexion of the wrist. Under normal use hundreds of injections can be performed before skin or veins need replacement. Supplied in storage box.

- Includes injectable metacarpal, digital and thumb veins on dorsal surface
- Soft, flexible fingers are separately molded
- Flexible wrist
- Skin rolls when veins are palpated
- Perform hundreds of injections before replacing vein & skins

- Light Hand 1017963 \$289.00**
- Dark Hand 1017964 \$289.00**

| Consumables | Item No. | Price |
|-------------|----------|---------|
| Light Skin | 1005665 | \$42.00 |
| Dark Skin | 1005667 | \$94.00 |

➤ Safe, economical injection simulators!



Intra-muscular Injection Pad

A simple trainer that simulates muscle tissue for handon training.

- Injection made to a depth of 50 mm
- Lifelike skin allows multiple punctures
- Will absorb fluid

1005190 \$124.00

BANDAGING & SUTURING

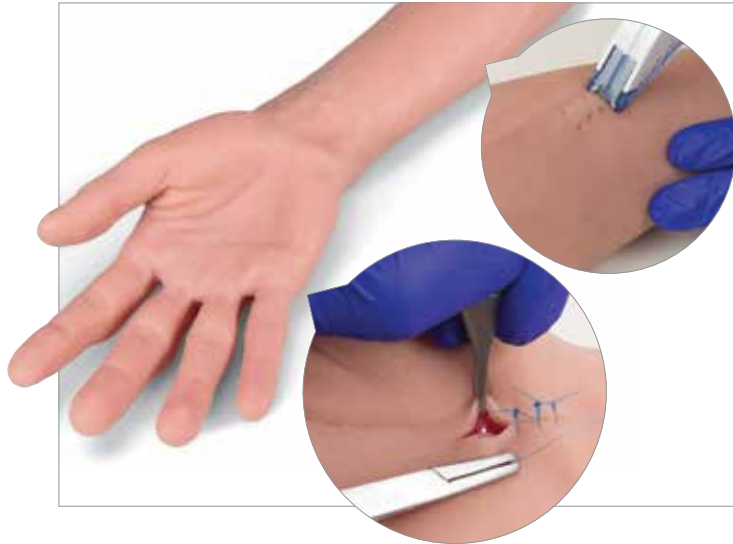

NEW

3B Scientific® Suture Training Arm

The realistic anatomy of the 3B Scientific® Suture Training Arm offers the possibility for suture training that is a lot more complex than with regular suture pads. Given its movable hand and fingers, even challenging sutures in hard to reach places like between the fingers can be practiced. Both the skin and the subcutaneous tissue are represented for a life-like suturing experience.

The instructor can inflict wounds independently wherever needed on the arm. Their size and form can be customised, leaving room for a large variety of training possibilities. Additionally, each wound can be sutured several times, making this trainer very economic and suitable even for larger skill training classes.

- Movable fingers for suture training of challenging wounds between fingers
- Skin and subcutaneous tissue differentiated for realistic suture experience
- Wounds can be inflicted by instructor anywhere on the training arm
- Each cut can be sutured several times
- For surgical staples procedure

1020904 \$380.00

Surgical Sally Bandaging Simulator

A readily available patient with 14 surgical wounds. The skin has been reformulated so it is drier, allowing the bandages to adhere better. Special vinyl formulations have been used to create the most lifelike look and feel possible.

The flexible, flesh-colored skin realistically responds to adhesives and all types of bandaging procedures. Wound closures feature surgical staples for the Mid-Sternal Split, Thoracotomy, Nephrectomy, Laparotomy, Abdominal Hysterectomy, and Amputation Stump. Staples and sutures cannot be removed. 3 year warranty. See full description online!

84 x 30.5 x 63.5 cm; 12.0 kg
1005590 \$830.00

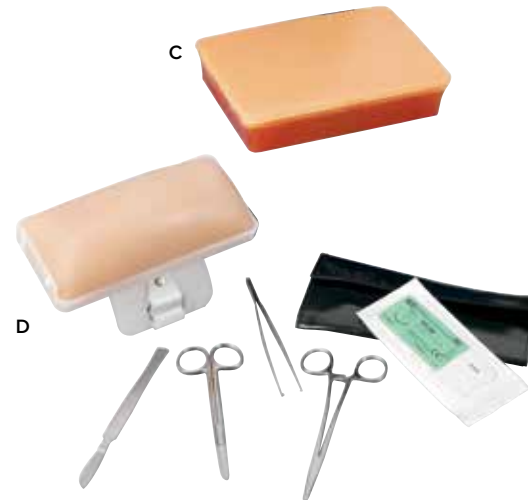
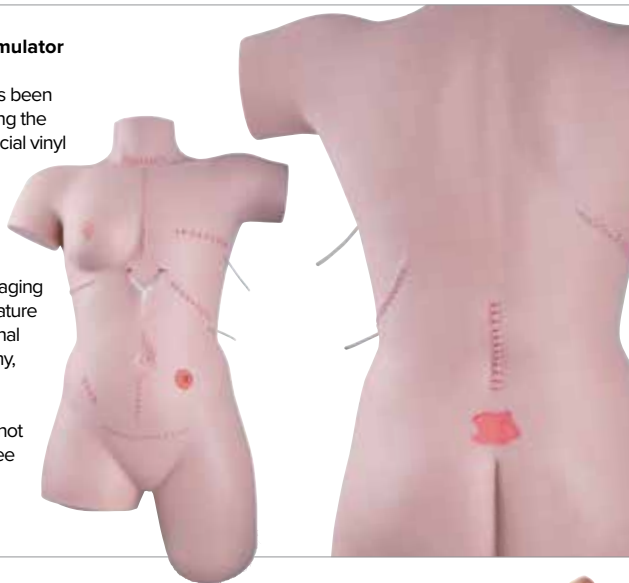

C. Life/form® Suture Kit

Train incisions and determining the depth of suturing and the technique to be used. Practice and demonstrate tying knots, stapling and placement of staples, use of surgical glue, suturing deep tissue, and suturing subcutaneous tissue. Features epidermis, dermis, fascia, fat, and muscle layers. The skin will allow placement and closure of superficial sutures. Includes suture pad, tray to hold pad, durable carrying case, needle holder, suture scissors, tissue forceps, scalpel, nylon suture and small case to hold the instruments.

1017981 \$162.00

D. Life/form® Interactive Suture Trainer

The trainer attaches easily to an arm, leg, or hip, allowing practise of suturing techniques in addition to essential communication and patient interaction skills. This convenient, cost-effective kit offers practice at all skill levels, including tying knots, placement of staples, and suturing both superficial and deep wounds. Wounds automatically open when cut. Includes suture pad, attachable pad base with straps, needle holder, suture scissors, tissue forceps, scalpel, soft carrying case, nylon suture, instrument case and instruction manual.

1018196 \$160.00

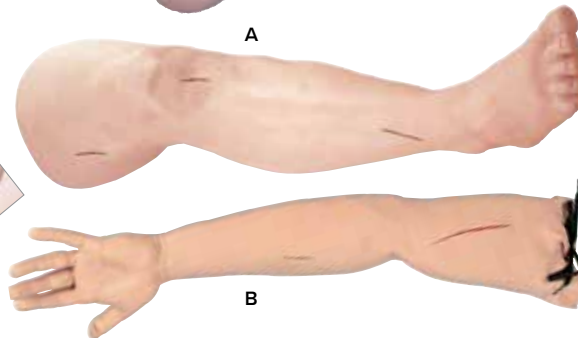

Suture and Stapling Practice Trainers

Made with a soft vinyl skin over a core of stitchable foam to provide a Lifelike suturing experience for students or a realistic suturing demonstration by an instructor. Soft and pliable for easy sewing, the skin is tough enough that sutures will not pull out when tightened. The unit is provided with three inwounds. In These can be sutured repeatedly until the skin around them is finally worn out; then, new can be cut. Conservatively, more than one hundred cuts can be made on the trainer and each of these cuts can be sutured several times.

- Realistic skin texture with wrinkles, pores, and visible finger prints
- Disposable limbs provide hundreds of suturing experiences before wearing out
- Trainer comes complete with a starter package of sutures, instruction booklet

A. Practice Leg 1005683 \$235.00

B. Practice Arm 1005585 \$174.00

BLOOD PRESSURE TRAINING



Blood Pressure Training System With Omni®

The Blood Pressure Training System includes a full-size adult left arm that may also be attached to the Code Blue® I Multipurpose Patient Care and BLS Manikin (W45001) and Susie Simon® Patient Care Simulator with Ostomy (W45011). It is a versatile training tool developed to assist health professionals teach the processes and skills required to perform blood pressure auscultation procedures and techniques

- Systolic and diastolic pressures, auscultation gap and pulse rate are adjustable
 - Cuff pressure can be seen on a display
- International power supply 100 to 240 VAC. Comes with one Omni® controller, soft carrying bag and instruction manual.

1018870 \$995.00

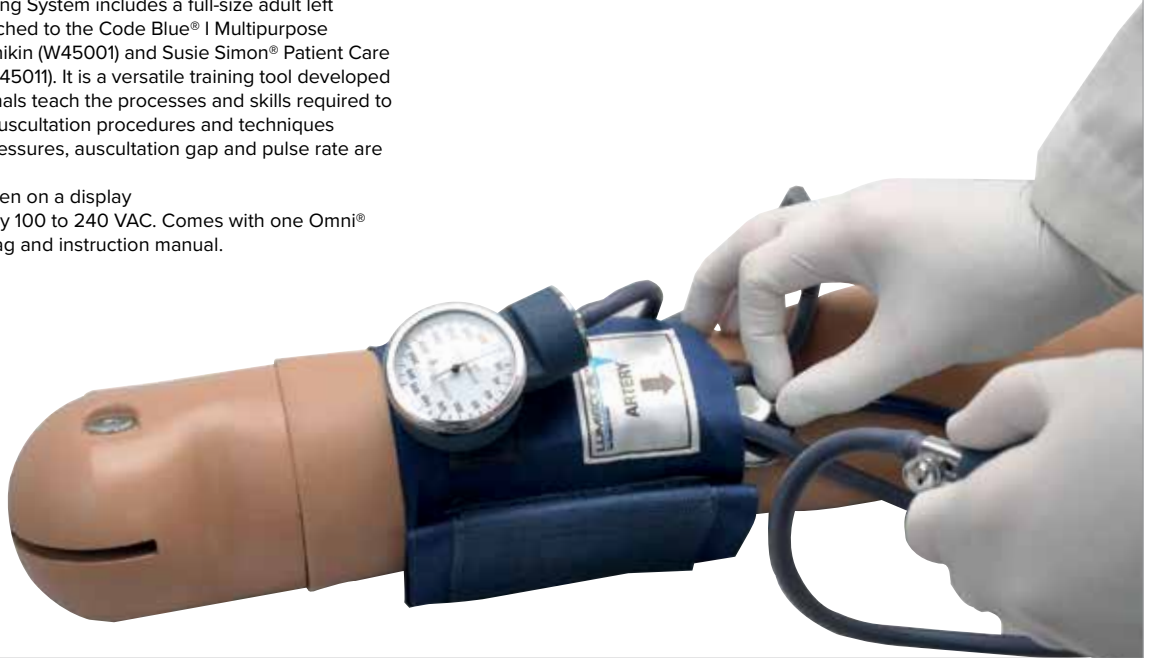

Blood Pressure Training Arm

Includes blood pressure trainer, cuff, 9-volt battery and carry case.

- Palpable antecubital pulse
- Blood Pressure Trainer with LCD guided operation
- Systolic, diastolic, heart rate and auscultatory gap are programmable
- Representation of both systolic and diastolic pressures
- Indication of gauge reading as pressure is increased or decreased
- Volume adjustable
- May articulate to adult manikins

Control Unit Allows Instructor to:

- Select systolic and diastolic settings
- Adjust pulse rate and volume
- Turn auscultatory gap on or off
- Easily calibrate unit for use with any sphygmomanometer

1017977 \$1,300.00

Improved features include:

- Redesigned and durable control unit
- Simple calibration procedure
- Palpable radial pulse
- Optional external speakers



Proscope™ Teaching Scope, Dual Head

A training aid that allows student and instructor to listen simultaneously.

Feature & benefits:

- Two sets of flexible chrome-plated brass binaurals
- Two spare pairs of eartips included
- Weighs 0.18 kg; overall length 113.03 cm
- 1 year warranty

1017512 \$18.00

PATIENT CARE

➤ Practice basic and advanced nursing, clinical, and emergency skills!



3B Scientific® Patient Care Manikin PRO

Build and evaluate advanced patient care and nurse aid competencies with scenario based training! The patient care manikin simulates an adult, life-size patient, with interchangeable genitals. It can be positioned like a real patient with natural movement of the arms, legs, and joints. It is made of durable, unbreakable, and water-resistant plastics for longevity in the everyday training use. The PRO version includes removable organs for additional patient care training features like catheterization, enema administration, ostomy care, irrigations and naso-gastric lavage and gavage.

Delivered with:

Organs (lungs, heart, stomach, bladder and intestinal section), injection pads (upper arm, thigh, and buttocks), intestine tube, catheter, duodenal probe, talcum powder, Vaseline, lubricant, amputation stump, inserts with wound depictions (upper arm and thigh), and tools for fitting.

Meets the OBRA requirements of Nurse Aide Training and Competency Evaluation Programs (NATCEP).

173 cm tall, delivered with assembly tools.

1018816 \$3,444.00

3B Scientific® Patient Care Manikin BASIC

The 3B Scientific® Patient Care Manikin is also available in a basic version, offering a variety of training possibilities for basic patient care and nurse aid competencies. It comes without organs but can be upgraded to include all training features of the PRO version using the Upgrade Kit available below.

174 cm, 14.4 kg

1018817 \$2,645.00

Upgrade Kit

You can easily upgrade the Basic Patient Care Manikin to the PRO version using this kit. It includes the inner organs and allows for training of catheterization.

1000504 \$872.00



All parts also fit older models. Replacement parts available online at 3bscientific.com/

Patient care training features:



Removable organs for advanced training features like catheterization



Wound treatment and care (laceration and abrasion)



Simplified assembly



Diabetic foot syndrome



PRO version delivered with organs



Hair care (washing, combing, drying)



Wound treatment and care (surgical staple seam)



Decubitus evaluation and care (stages 2-4)

Nurse Training Baby, New Born

Accessories include syringe, suction catheter, feeding tube, urinary catheter, urine collection bag, catheter lubricant and carrying bag.

This advanced and incredibly realistic model with male and female features includes:

- Internal organs (heart, lung, intestine system, stomach, and bladder)
- Removable belly covering, head, arms, and legs
- Interchangeable genital organs
- Soft ears

It allows trainees to practice both basic and medical infant care such as:

- Tracheotomy care
- Male and female catheterization
- Insertion of a tube into mouth or nose
- Enema insertion
- Femoral, gluteal intramuscular and subcutaneous injections
- Palpitation of fontanels

52 cm; 2.3 kg

1000505 \$953.00



Advanced Infant Intubation Head with Board

This station trainer incorporates new skin technology. This new material eliminates tearing of the airway, caused by beginning student intubation attempts. Translucent property allows for life-like illumination of the airway and neck as the skill is attempted. Vocal cords are highlighted for easy viewing, the tongue swells, and all the anatomical landmarks are present. 3-year warranty.

38.1 x 25.4 x 20.3 cm; 4.08 kg

1017236 \$1,019.00

➤ Upgrade as your skills increase!



1. Add an IV Arm - 1017949



2. Add an IV Leg - 1017950



3. Add the Single Intraosseous Infusion Leg - 1017951



4. Add the ECG/Umbilical Cannulation Skin - 1017952

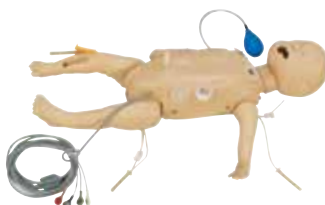

5. Add the Airway Management Head - 1017953



Start with Life/form® Crisis Baby

Basic Life/form® Crisis Baby

This full-body infant manikin was created to offer realistic training and practice of infant airway management and CPR education. Anatomically correct in both size and detail. Anatomical landmarks provide key features necessary to learn proper infant handling in emergency situations. Also allows practice of intubation, and suction techniques can be performed and evaluated. Designed for use with an uncuffed endotracheal tube measuring up to 1/8 in (4 mm) inside diameter. Manikin can be upgraded by adding the Manikin Modular Component upgrades available. Includes artificial blood, IV bag, umbilical cord replacements, carry case, spray pump lubricant, and instruction manual. 3-year warranty. See 3bscientific.com for more details.

1017248 \$1,010.00

CHARTS & POSTERS

Wall Charts Guide

Wall charts are bigger in size, and are available mounted on wooden rods, or unmounted. They are printed on tear-resistant, waterproof paper and measure 84 x 200 cm.



The Nervous System, Front Side
Mounted 1001190

Mounted wall charts are \$60.00 ea.

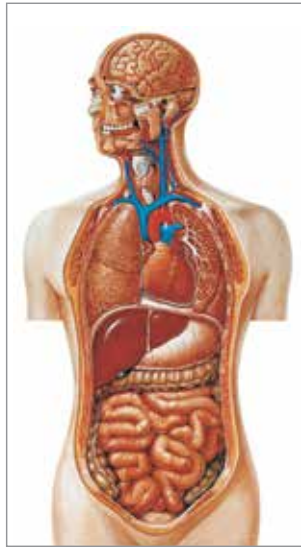

Torso Chart
Unmounted 4006519
Mounted 1001159

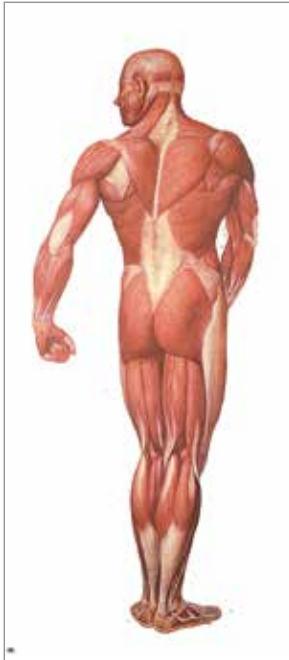

The Human Musculature Chart, Back Side
Mounted 1001153

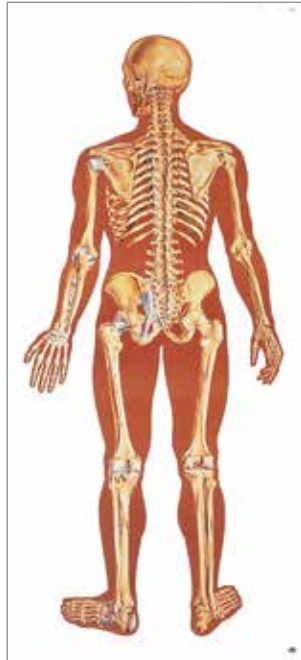

Human Skeleton with Ligaments, Back Side
Mounted 1000012
Unmounted 4006513

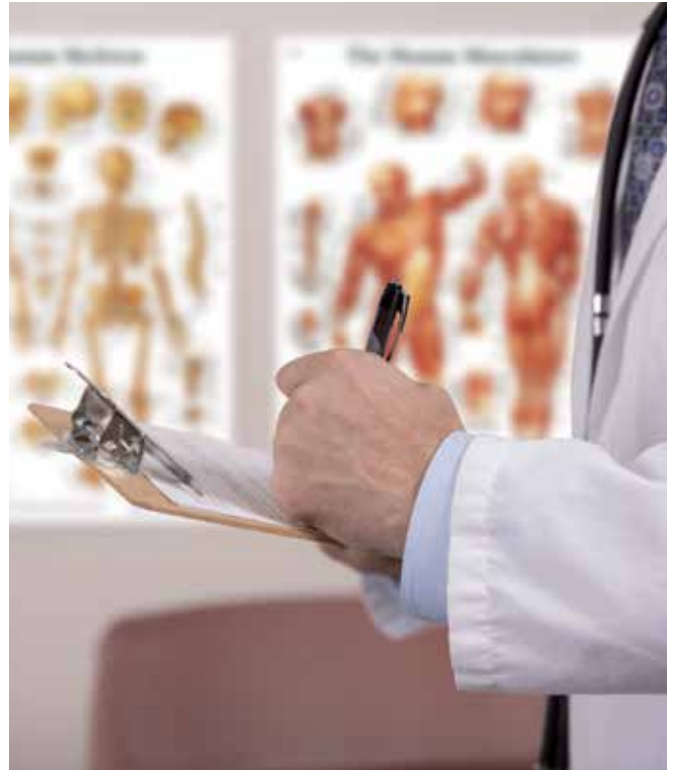

| | Mounted | Unmounted |
|-----------------------------------|---------------|---------------|
| Muscle | | |
| The Human Musculature, Rear | 1001153 | not available |
| Muscle Tissue | 1001212 | 4006551 |
| Skin | | |
| The Skin | not available | 4006530 |
| Vegetative System | | |
| The Vegetative Nervous System | 1001218 | not available |
| Endocrine System | | |
| The Endocrine Glands | 1001200 | 4006545 |
| Heart | | |
| The Anatomy of the Heart I | not available | 4006552 |
| Organs | | |
| The Male Pelvic Organs | not available | 4006527 |
| The Female Pelvic Organs | 1001175 | 4006528 |
| The Internal organs | not available | 4006517 |
| The Kidney | 1001165 | not available |
| The Speech Organs | 1001157 | 4006518 |
| The Anatomy of the Eye I | not available | 4006521 |
| Cell | | |
| Human Cell Structure | not available | 4006531 |
| Cell Division II, Meiosis | 1001210 | 4006550 |
| Bacteria & Parasites | | |
| Bacteria | 1001194 | 4006541 |
| Intestinal Parasites I | not available | 4006526 |
| Intestinal Parasites II | not available | 4006532 |
| Vascular System | | |
| The Vascular System | not available | 4006515 |
| Dental | | |
| Healthy Denture | 1001167 | 4006524 |
| Torso | | |
| The Human Torso | 1001159 | 4006519 |
| Pregnancy & Childbirth | | |
| Position of the Child | not available | 4006562 |
| Embryology I | 1001222 | 4006560 |
| Embryology II | 1001224 | 4006561 |

Charts Guide

Anatomical wall charts and posters from 3B Scientific are ideal for teaching human anatomy, patient education and medical studies! All anatomy charts are available in 50 x 67 cm unless otherwise stated. An excellent addition to anatomical models in the classroom or doctors office. Available unlined (paper version) or laminated. Posters are available in several languages.

Laminated charts are \$21.00 ea. and unlined (paper version) are \$14.00 ea.

| Bones | Laminated | Paper |
|-----------------------------------|------------------|---------------|
| Human Skeleton | 1001468 | 4006651 |
| Human Skull | 1001468 | 4006651 |
| Shoulder and Elbow | 1001482 | 4006658 |
| Hand and Wrist | 1001484 | 4006659 |
| Knee Joint | 1001488 | 4006661 |
| Pelvis and Hip | 1001486 | 4006660 |
| Foot and Ankle | 1001490 | 4006662 |
| Muscle | | |
| Human Musculature | 1001470 | 4006652 |
| Pathologies | | |
| Osteoporosis | 1001472 | 4006653 |
| Arthritis | 1001474 | 4006654 |
| Sports Injuries | 1001494 | 4006664 |
| Diseases of the Eye | 1001498 | 4006666 |
| Rhinitis and Sinusitis | 1001504 | 4006669 |
| Diseases of the Middle Ear | 1001506 | 4006670 |
| Respiratory Tract Infections | 1001508 | 4006671 |
| Skin Cancer | 1001514 | 4006674 |
| Alcohol Dependence | 1001620 | 4006727 |
| Nicotine Dependence | 1001622 | 4006728 |
| Allergies | 1001596 | 4006715 |
| Decubitus Ulcers | 1001606 | 4006720 |
| Flu (Influenza) | 1001608 | 4006721 |
| HIV and AIDS | 1001610 | 4006722 |
| Pneumonia | 1001518 | 4006676 |
| Common Cardiac Disorders | 1001526 | 4006680 |
| Varicose Veins | 1001534 | 4006684 |
| Diseases of the Digestive System | 1001548 | 4006691 |
| Colon Cancer | 1001550 | 4006692 |
| Hepatitis | 1001552 | 4006693 |
| Diabetes | 1001554 | 4006694 |
| Cholesterol | 1001558 | 4006696 |
| Stroke | 1001590 | 4006712 |
| Alzheimer's Disease | 1001592 | 4006713 |
| Organs | Laminated | Paper |
| Human Eye | 1001496 | 4006665 |
| Human Ear | 1001500 | 4006667 |
| Human Heart | 1001524 | 4006679 |
| The Larynx | 1001502 | 4006668 |
| The Skin | 1001512 | 4006673 |
| Lymphatic System | 1001540 | not available |
| The Liver | 1001544 | 4006689 |
| The Urinary Tract | 1001562 | 4006698 |
| Kidney | 1001564 | 4006699 |
| The Prostate Gland | 1001566 | 4006700 |
| Human Brain | 1001584 | 4006709 |
| Pregnancy & Childbirth | | |
| Pregnancy | 1001572 | 4006703 |
| Childbirth | 1001574 | 4006704 |
| Breastfeeding | 1001578 | 4006706 |
| Birth Control | 1001580 | 4006707 |

| Gynecology | Laminated | Paper |
|--|------------------|--------------|
| The Female Genital Organs | 1001568 | 4006701 |
| The Female Breast | 1001576 | 4006705 |
| Stomach | | |
| The Gastrointestinal System | 1001542 | 4006688 |
| The Stomach | 1001546 | 4006690 |
| Blood Vessel & Nervous System | | |
| The Blood | 1001538 | 4006686 |
| Blood Vessels & Nerve | 1001530 | 4006682 |
| The Vegetative Nervous System | 1001582 | 4006708 |
| The Nervous System | 1001586 | 4006710 |
| Spinal Nerves | 1001588 | 4006711 |
| Acupuncture | | |
| Foot Reflex Zone Massage | 1001624 | 4006729 |
| Ear Acupuncture | 1001628 | 4006731 |
| Body Acupuncture | 1001626 | 4006730 |
| Dental | | |
| The Teeth | 1001510 | 4006672 |
| CPR | | |
| Basic Life Support | 1001616 | 4006725 |
| Lungs | | |
| The Respiratory System | 1001516 | 4006675 |

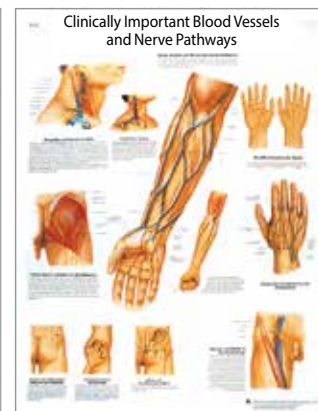
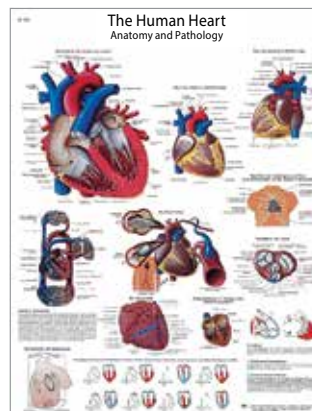
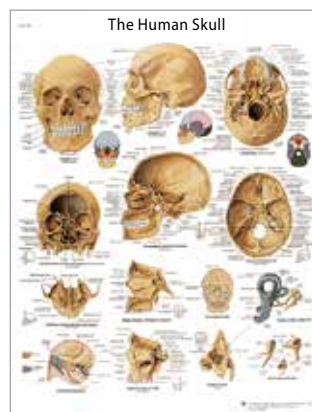

Please go online to 3bscientific.com or scan the QR code to see all available versions.





BIOLOGY

3B Scientific is more than just human biology! Learn about zoology with our animal skeletons and animal models. Botany models, including cellular and molecular models, are great for engaging students in group and hands-on learning. And what science lab would be complete without student microscopes, and experiment supplies?

Sweet Pea *Pisum Sativum*,

Enlarged 7 Times Life-Size, 12-part

Family: Papilionaceae/Leguminosae

There are over 17,000 members of the Papilionaceae family, named for its butterfly-like zygomorphic symmetry of the corolla. The corolla consists of petals, 2 wings, and the keel that comes from two petals which have grown together. This model has 11 parts and is mounted on a base. Use this model to teach the principals of genetics that Gregor Mendel discovered using Sweet Peas. Easily examine the Parent and F1 generations and discuss sexual and asexual reproduction.

10 x 7 x 10.5 in; 0.3 kg

1000535 \$372.00



Magnetic connections for easy, hands-on demonstrations.



Study Heliotropism

Tissue Structure of a Sunflower

Stem, *Helianthus Annuus*

Detailed longitudinal and lateral view, 200 times magnified. On Baseboard.

17.5 x 9.5 x 4 in; 2.2 kg

1005130 \$587.00

Meadow Clary *Salvia Pratensis*, Enlarged 15 Times Life-Size, 4-part

Family: Labiateae

At 15 times magnification, the model shows the detailed structure of a single flower with its pollination mechanism. For further illustration, the model separates into four components and the typical barrier mechanism is flexibly mounted. The four-sided stalks and the lip-shaped flowers are characteristic of labiates species. Labiates often are spice, perfume, or medicinal flowers.

18 x 28 x 30 cm; 0.6 kg

1000534 \$378.00

Dandelion *Taraxacum officinale*, Enlarged 10 - 20 Times Life-Size, 3 individual Models

Family: Asteraceae

Dandelion belongs to the Asteraceae family of composite flowers. The Dandelion model contains three separate models, each on their own base. The inflorescence is enlarged 10 times life-size. It contains up to 200 florets in its tight bracts. The florets has five lobes and are magnified to 20 times life-size. Through an intricate process of fertilization, the seed begins to mature. Shown at 20 times life-size the seed ripens and the beak grows to three or four times its length. When it opens, the Dandelion's characteristic puff ball allows dissemination of its seeds by wind. Flower: 8 x 10 x 13.5 in enlarged 10x, Floret: 5 x 5 x 13 in enlarged 20x, Seed: 5 x 5 x 13 in enlarged 20x.

1000532 \$534.00



**Genuine Camomile *Matricaria chamomilla*,
Enlarged 10 Times Life-Size, 2-part
Family: Asteraceae**

Asteraceae or composite flowers are characterized by the torus, a series of florets arranged in dense heads, that resemble a single flower. The white ray florets are furnished with a ligule, while the disc florets are yellow. The composite flower head is shown enlarged 10x and halved to allow outer and inner views. A single tubular fertile flower is shown enlarged 70x for detailed examination of its inner structures. Chamomile is the perfect flower to teach the natural application of the Fibonacci sequence. The tubular florets mature in sequence from the outside in a spiral configuration to the center. The model shows the maturation process from immature inner flower out to mature stamen.

12 x 9 x 11.5 in; 0.7 kg
1000533 \$354.00

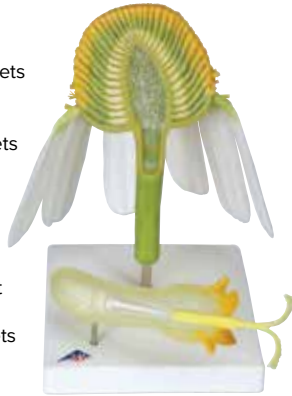

**Tulip *Tulipa Gesneriana*,
Enlarged 3 Times Life-Size, 2-part
Family: Liliaceae**

Monocotyledonous Lily grasses are characterized by underground stems called bulbs that vegetatively reproduce. Likewise their large funnel-shaped flowers are two sets of three tepals in radially symmetrical whorles. The inner circle is produced by two sets of three detachable stamina. The inner chasm is painted a delightful gradient starting in red shifting to yellow finally to finish in a deep black. This colorful, large flower is adapted to insect pollination. Onion (*Allium cepa*) and the White lily (*Lilium candidum*) have similar flower shapes.

23 x 24 x 52 cm; 0.83 kg
1017832 \$273.00



**Wheat *Triticum Aestivum*,
Enlarged 15 Times Life-Size, 5-part
Family: Gramineae**

The narrow, sharp and parallel-running leaves are typical of monocotyledonous grasses. Flowers of most grasses are adapted for wind pollination. The spike is made of 2 or 3 flowered ears. The ears are covered by two glumellata, while the flowers are covered by stiff protective hairs called awnes. In some species like barley, the awns can contribute significantly to photosynthesis. There are three stamina and a pistil with a large surface area. As the flower matures the stamina protrude from the center glumella and prostrate. The individual ears can be separated for a detailed view of the immature stamen and pistil.

6 x 8 x 21 in, 1 kg
1017833 \$442.00



**Celandine or Pilewort *Ficaria verna*,
Enlarged 10 Times Life-Size, 1-part
Family: Ranunculaceae**

The family of Ranunculaceae depicts an ancient flower structure. Also known as both the buttercup or crowfoot family the number of the flower parts are indefinite, especially the male and female parts. In this case, the flower has 8 petals encased in 3 slim sepals. There are a number of stamina and pistils and the carpels are unfused. Looking down into the model, you can see the pattern of Fibonacci's sequence in the spiraling pistils.

39 cm; 0.4 kg
1017828 \$264.00

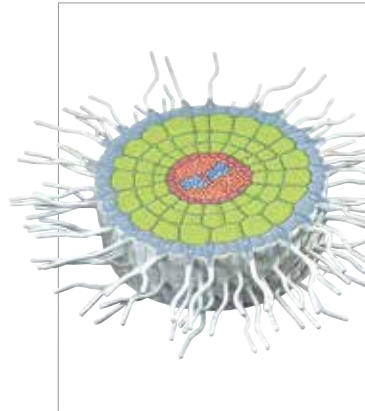

Absorption Zone of the Root

This relief model shows the absorption zone of a dicotyledonous plant, White Mustard (*Sinapis alba*). Identify the root hairs and vascular bundles that contain the xylem and phloem. Discuss primary versus advantageous root structures and how that influences osmosis and transportation of raw materials.

43 x 43 x 20 cm; 1.5 kg
1002505 \$353.00

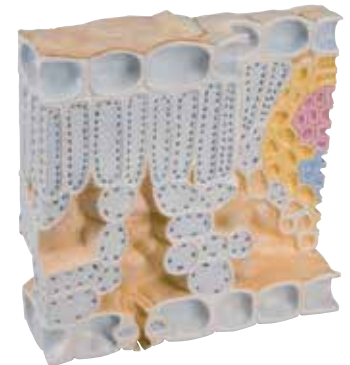

Block Model of Leaf Structure

This model shows the histological structure of a Christmas rose (*Helleborus niger*). Examine individual cells and their role in the larger vascular system. Identify the stomata and guard cells to discuss the intricacies of transpiration.

Magnified 1500 times.
35 x 37 x 11 cm; 2.0 kg
1002504 \$299.00

**Dicotyledons -
Stem Cross Section**

Cross section of a Creeping Buttercup stem with collateral open vascular bundles. The model shows the typical stem structure of a dicotyledon enlarged by a factor of 250.

1002506 \$389.00

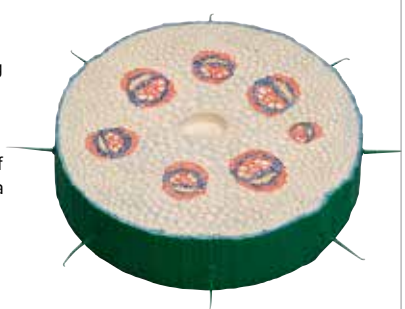



Rapeseed or Canola Seed Brassica Napus ssp. Oleifera, Enlarged 12 Times Life-Size, 3-part

Family: Brassicaceae

Brassicaceae, formerly known as Cruciferae, is named for its Croslike (Cruciferous) flower. Unique in the plant world for having 4 petals, Rapaseed does not follow Fibonacci's sequence.

Rapaseed lends itself to teaching the formidable inTriangle of U in concept. One petal is removable for detailed study of the sepal and stamen. A ripe pod, magnified 3x life-size is depicted in cross section, removable from base.

11 x 9.5 x 14 in
1000531 \$324.00

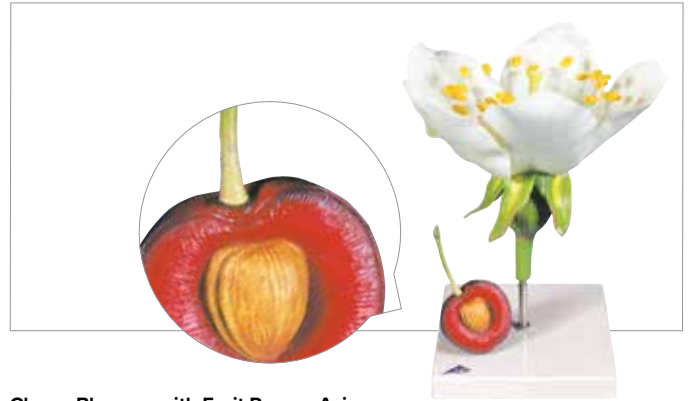

Cherry Blossom with Fruit Prunus Avium, Enlarged 7 Times Life-Size, 3-part

Family: Rosaceae

This model shows the blossom of the sweet cherry (3-parts) enlarged 7 times as well as a cherry fruit enlarged 3 times. The cherry blossom can be split into two halves to reveal the removable ovary with style and stigma.

32.5 cm; 0.6 kg
1020125 \$329.00



Potato Flower Solanum Tuberosum, Enlarged 8 Times Life-Size, 2-part

Family: Solanaceae

In nature, the potato flower branches usually divide into two stalks, each with multiple flowers. The gamopetalous corolla's 5 points are radially symmetrical, marked by yellow lines that equally transverse & divide. The 5 stamen sets are fused to form a conical stamina. The corolla and stamina detach to reveal the superior pistil. The powder coated paint on the stamina and stem give life-like texture that provides realism to the model. 5 petals, 5 sepals, 5 sets of stamen all fall into Fibonacci's sequence. Similar flower structures to the Potato flower are Peppers (*Capsicum annum*) and Tomatoes (*Lycopersicon esculentum*).

7 x 7 x 15 in; 0.5 kg
1017830 \$155.00



Apple Blossom Malus Pumila, Enlarged 5 Times Life-Size

Family: Rosaceae

An apple flower is the perfect model of 5's in Fibonacci's sequence. The flower is radial, five-whorle and five-part. Five sepals form the inner whorle, next to them are 5 petals. There are typically 5 inflorescence on a branch. The stamina are bunched in five's, this model has 4 sets of stamen. While individual flowers vary in numbers of sets they are always in multiples of five. Hawthorn (*Crataegus monogyna*) and Cherry (*Cerasus vulgaris*) have similar flowers. A spectacularly beautiful model, the rounded white leaves are barely tinted with pink. The powder-coat paint on the stem and anthers give this model a realistic look and feel.

10 x 9 x 16.5 in; 0.91 kg
1017829 \$175.00



Wild Rapa Sinapis Arvensis, Enlarged 12 Times Life-Size, 3-part

Family: Brassicaceae

The sepals and petals standing in two whorled circles form a crossshape, leading to the former Cruciferous family name. The stamina are in two whorles. The two stamina in the outer circle are shorter than the four stamina in the inner circle. The ovary is divided by a wall and the ovules are linked to the edge of this wall. The carpel can be removed from the silique and disassembled into two pieces.

13 x 13 x 14 in ; 0.75 kg
1017831 \$229.00

CELL LIFE & DIVISION

The Plant Cell

The two-piece model presents the structure of a typical plant cell with cytoplasm and cell organelles, as viewed from an electron microscope. For purposes of better illustration, all important organelles are raised and displayed in color.

20 x 14 x 32 cm; 0.8 kg

1000524 \$342.00



The Animal Cell

This two-piece model shows the form and structure of a typical animal cell as viewed from an electron microscope. For the purpose of better illustration, all important organelles are raised and displayed in color. On removable base.

21 x 11 x 31 cm; 0.8 kg

1000523 \$342.00



The Plant Cell STICKYchart™

The Plant Cell STICKYchart™ presents the structure of a typical plant cell with cytoplasm and cell organelles, as viewed from an electron microscope. For purposes of better illustration, all important organelles are displayed in color.

18 x 24 in; 0.8 kg

3006051 \$34.00



The Animal Cell STICKYchart™

The highly detailed Animal Cell STICKYchart™ shows the form and structure of a typical animal cell as viewed from an electron microscope. For the purpose of better illustration, all important organelles are displayed in vibrant color.

18 x 24 in; 0.8 kg

1000523 \$34.00

➤ **3B Scientific STICKYcharts™:** Printed in full color on durable vinyl with a 3M™ adhesive backing. The non-destructive adhesive affixes to walls, doors, windows, whiteboards, metal, cabinets and most any clean surface. Can be removed and re-affixed to surfaces many times.

Human Cell, in Glass at 40,000 Times Life-Size

This one of a kind model represents an undifferentiated human cell at an enlargement of 40,000 times. It shows the structure of the smallest unit of any living creature capable of independent life, as seen through an electron microscope. The high-quality human cell model shows the essential function-bearing cell organelles with stunning beauty and their arrangement in the model provides a momentary snapshot of the dynamic balance of a cell. The cell nucleus, a few mitochondria and the lysosomes are shown in section, so that their internal structure is visible. The glass cell is an eye-catcher in many exhibitions and has received several distinctions as in Worlddidac gold award in. Whether you are looking for a model for a display case, museum mount or to make a statement in a lobby – this glass cell model is of the finest quality and sure to please.

60 x 46 x 46 cm; 13 kg
1008554 \$4,448.00



3B Scientific® Magnetic Model Series

These three-dimensional relief models are painted according to the usual coloring methods of microscopy, making the process of mitosis and meiosis easy to understand. The models are equipped with magnets at the back so they can be easily arranged on a magnetic board in the classroom. Each series is supplied in a storage system which can be fastened to the wall. A detailed description and handouts for your lessons are included. Comes with metal stand.

A. Mitosis Model

This 3B Scientific® Model Series shows the 9 phases of mitosis on the basis of a typical mammal cell at an enlargement of approx. 10,000 times:
 60 x 40 x 6 cm; 1.5 kg
1013868 \$484.00

B. Meiosis Model

Our Meiosis models show the 10 stages of meiosis on the basis of a typical mammal cell at an enlargement of approx. 10,000 times:
 60 x 40 x 6 cm; 1.7 kg
1013869 \$497.00

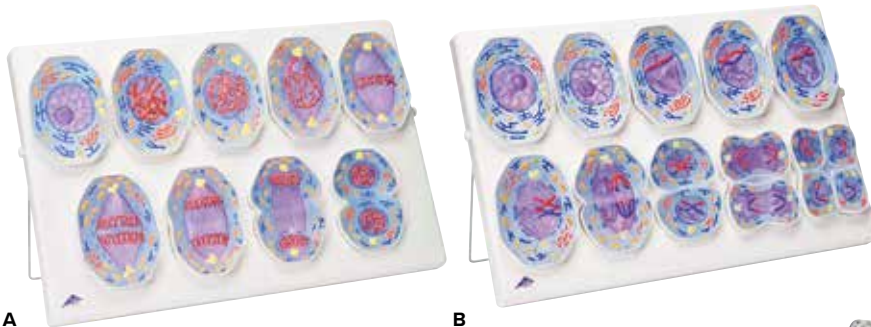

Embryonic Development of a Frog, 12 stages

Rana temporaria, the common frog, provides an excellent backdrop for the study of fertilization and embryonic development. Track the blastula as it divides and forms more specialized cells. 30x life-size.
 37x36x13 cm³; 1.5 kg
1002501 \$333.00



ANTHROPOLOGY SKULLS

► Specimens featured in the museum collection at the Institute of Anthropology and Human Genetics for Biologists.



KMN-ER 406

This model is a high-quality casting of a reconstruction of the Kalvarium skull (KMN-ER 406) with a partial mandible (Omo L. 7a-125). The Kalvarium skull is approximately 1.7 million years old and was discovered at Lake Rudolph (now called Lake Turkana) in 1970. The partial mandible comes from a different dig but is clearly from the same species. The classification of the species has not yet been indisputably clarified. Discussions continue as to whether the specimen is an Australopithecus boisei or a Paranthropus boisei. Example of a pre-human hominid.

Discovered at: Lake Turkana, formerly Lake Rudolph
Year discovered: 1970
Age: 1.7 million years
18 x 18 x 22.5 cm; 0.8 kg
1001298 \$249.00



Steinheim skull

This Steinheim model is a detailed casting from Berkheimer's reconstruction (1936, skull with no jawbone). The original of this skull from a predecessor of Neanderthal man was a Homo (sapiens) steinheimensis aged between about 25 and 35 and was discovered in a gravel in Steinheim, southern Germany, in 1933.

Discovered at: Steinheim an der Mur, Germany
Year discovered: 1933
Age: Approximately 250,000 years
19 x 12.5 x 21.5 cm; 0.7 kg
1001296 \$249.00



Sinanthropus Pekinensis

This skull is an accurate casting of a Sinanthropus skull reconstructed by Weinert and modelled from drawings by Black and Weidenreich after all the original bone specimens had been lost. Sinanthropus belongs to the genus Homo erectus pekinensis (Sinanthropus pekinensis) and can be seen as a typical example of early man.

Discovered at: Zhoukoudian
40 km south west of Peking
Year discovered: 1929-1936
Age: 400,000 years
21 x 14.5 x 21.5 cm; 0.9 kg
1001293 \$249.00



Biface

Accurate reproduction of a biface made from quartzite. The original finding was probably used by an ancestor of the Neanderthals as a multi-purpose tool.

Material: Liquid wood
Age: 0.3 - 0.4 Mya
Place found: Neandertal
19 x 9 x 5 cm
1018514 \$125.00



La Chapelle-aux-Saints

Cast from a reconstruction of the LaChapelle-aux-Saints skull, the model skull is an accurate copy of one belonging to a 50-55 year old male Neanderthal from ancient Europe of the species *Homo (sapiens) neanderthalensis*.

Discovered at: Southern France
 Year discovered: 1908
 Age: 35,000 to 45,000 years
 22 x 16 x 22.5 cm; 0.9 kg
1001294 \$249.00



Crô-Magnon

This wonderful casting is a reconstruction of an early hominid called Crô-Magnon man. The age of the original is dated to be 20,000 to 30,000 years old. The skull itself belonged to an early modern man of the species *Homo sapiens* from the ice age of the neo-Palaeolithic era.

Discovered at: Vézère/southern France
 Year discovered: 1868
 Age: 20,000 to 30,000 years
 21.5 x 15 x 24.5 cm; 0.9 kg
1001295 \$249.00



Kabwe or Broken Hill

An accurate casting of a skull reconstructed from an original that was discovered in an iron ore working at Broken Hill, in northwest Rhodesia (modern-day Kabwe in Zambia). It is an example of the early man, *Homo sapiens rhodesiensis* or a *Homo erectus rhodesiensis*, and indications exist to point to both these classifications. For this reason, there is also a wide range in the estimates of the specimen's age based on differing scientific assumptions. An early example of an ancient *Homo sapiens* (as classified by Henke and Rothe 1994) or a *Homo erectus rhodesiensis*.

Discovered at: Broken Hill, modern-day Kabwe in Zambia
 Year discovered: 1921
 Age: Between 300,000 and 125,000 years
 21 x 15.5 x 23.5 cm; 0.8 kg
1001297 \$249.00



Advantages of 3B Scientific® Animal Specimens

- + Completely genuine animal specimens
- + No animals have been bred or killed solely for the purpose of making these specimens
- + Only adult animals with closed epiphyseal plates used
- + Origin and preparation of animals conform to legal stipulations
- + Expert European manufacture, professionally prepared
- + No risk of infection due to infectious zoonotic pathogens (certified)
- + Depiction of natural animal anatomy
- + All bones, no matter how tiny are mounted
- + No yellowing
- + Perfect for lessons on comparative anatomy, e.g. animals – humans

Note: Shape, dimensions, weight and number of bones may vary

Horse (*Equus ferus caballus*)

Taxonomy:

Class: Mammals
 Order: Odd-toed ungulates
 Family: Horses
 Diet: Herbivore
 Size: approx. 50 – 200 cm
 Weight: approx. 100 – 1200 kg
 Age: approx. 20 – 50 years
 Skeleton: approx. 252 individual bones

Dentition formula:

Number: 36 – 44
 Incisors (I): 3/3
 Canines (C): 0-1/0-1
 Premolars (P): 3-4/3-4
 Molars (M): 3/3



Horse Skeleton (*Equus ferus caballus*)

The real bone specimen of an adult horse is composed of approximately 252 individual bones. It represents a typical example of the order of odd-toed ungulates. There are only minimal differences in body plan between the different breeds of horses. You can choose between a female or a male item. The skeleton is mounted on a moveable base plate.

Length: approx. 250 – 300 cm
 Width: approx. 60 – 70 cm
 Height at withers: approx. 140 – 170 cm
 Weight: approx. 170 – 200 kg



♀ **Horse Skeleton (*Equus ferus caballus*), Female, Specimen**
1002541 \$9,325.00

♂ **Horse Skeleton (*Equus ferus caballus*), Male, Specimen**
1021003



Horse Skull (*Equus ferus caballus*), Specimen

Bone specimen of a horse skull consisting of approximately 37 individual bones, which are rigidly connected to each other. All the teeth are firmly attached to the jaws.

Length: approx. 60 cm
1021006 \$660.00

Half Horse Skull (*Equus ferus caballus*), Specimen (not shown)

Longitudinal section through the real skull of an adult horse. Clearly visible are the size of the nasal bone, the nasal concha, the frontal sinus and cranial cavities as well as the maxillary sinus and nasal cavities.

Length: approx. 60 cm
1021008

➤ More genuine animal skeletons and skulls at 3bscientific.com



Horse Hoof (*Equus ferus caballus*), Plastinated Slice

Longitudinal section through a real horse hoof encapsulated in acrylic glass. The plastinate enables the observation of complex anatomical structures and thus opens up completely new insights into fundamental functional relationships.
 Dimensions: approx. 20 x 16 x 2.3 cm
 Weight: approx. 1 kg
1005381 \$249.00

Horse Foot and Hoof (*Equus ferus caballus*), Specimen

Prepared, real, front or hind horse foot up to the carpal joint or tarsal joint respectively. The individual bones are rigidly connected to each other. The hoof capsule is supplied separately with the foot.

Note: In order to reduce "consumption of material" to an absolute minimum, your order will generally be fulfilled with a front or hind foot chosen at random.

1021053 \$362.50



Front and Hind Legs of a Horse (*Equus ferus caballus*), Specimen

Real bone specimens from an adult horse. Each front leg up to and including the shoulder blade and each hind leg up to the hip joint. Rigidly mounted on a base plate.

1021052 \$687.50

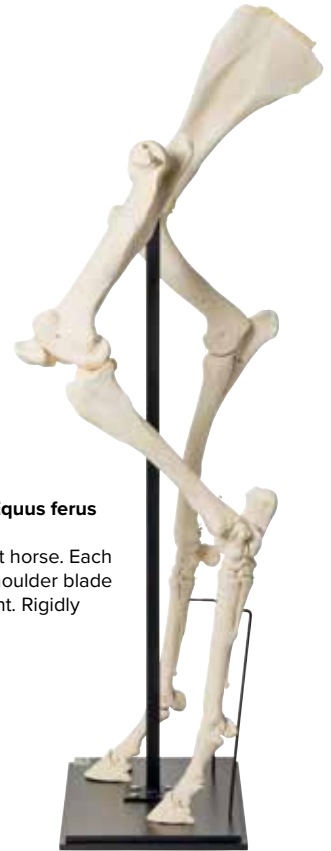

Great Apes

Taxonomy:

Class: Mammals
 Order: Primates
 Family: Great apes
 Diet:
 Western gorilla (*Gorilla gorilla*): Omnivore
 Common chimpanzee (*Pan troglodytes*): Omnivore
 Bornean orangutan (*Pongo pygmaeus*): Herbivore

Dentition formula:

Number: 32
 Incisors (I): 2/2
 Canines (C): 1/1
 Premolars (P): 2/2
 Molars (M): 3/3

Primate Skulls, Replicas

Primate skulls particular suitable for comparative studies. With detailed description of distinctive features. The templates for the castings were original skulls belonging to the collections of the Johann Wolfgang Goethe University of Frankfurt am Main (chimpanzee) and the Senckenberg Research Institute and Natural History Museum in Frankfurt am Main (orangutan, gorilla). Natural cast made from unbreakable plastic.

♂ Gorilla Skull (*Gorilla gorilla*), Male, Replica

Dimensions: approx. 26 x 16.5 x 19.5 cm
 Weight: approx. 0.8 kg
1001301 \$374.00



♀ Chimpanzee Skull (*Pan troglodytes*), Female, Replica

Dimensions: approx. 17 x 11.5 x 14 cm
 Weight: approx. 0.5 kg
1001299 \$288.00



♂ Orangutan Skull (*Pongo pygmaeus*), Male, Replica

Dimensions: approx. 22 x 16 x 18 cm
 Weight: approx. 0.6 kg
1001300 \$326.00





Domestic Pig (*Sus scrofa domesticus*)

Taxonomy:

Class: Mammals
 Order: Even-toed ungulates
 Family: Real pigs
 Diet: Omnivore
 Size: approx. 120 – 180 cm
 Weight: approx. 50 – 150 kg
 Age: 8 – 12 years
 Skeleton: approx. 223 individual bones

Dentition formula:

Number: 44
 Incisors (I): 3/3
 Canines (C): 1/1
 Premolars (P): 4/4
 Molars (M): 3/3



Domestic Pig Skeleton (*Sus scrofa domesticus*)

Prepared, real skeleton of an adult domestic pig consisting of approximately 223 individual bones, which are rigidly connected to each other. It is a typical representative of the order of even-toed ungulates. The choice between a female or a male item is available. The skeleton is mounted on a moveable base plate.
 Length: approx. 1.30 – 1.50 m
 Width: approx. 40 – 50 cm
 Height: approx. 75 – 90 cm
 Weight: approx. 75 – 120 kg



Domestic Pig Skull (*Sus scrofa domesticus*)

Bone specimen of a real domestic pig skull with all the typical characteristics of a pig's head. The choice between the skull of a female or a male domestic pig is available. The skull of the male pig is shorter but wider than that of the female animal.
 Length: approx. 30 cm



Domestic Pig Skull (*Sus scrofa domesticus*), Female, Specimen 1021000



Domestic Pig Skeleton (*Sus scrofa domesticus*), Female, Specimen 1020996 \$5,952.00



Domestic Pig Skull (*Sus scrofa domesticus*), Male, Specimen 1021001



Domestic Pig Skeleton (*Sus scrofa domesticus*), Male, Specimen 1020998

Domestic Pig Foot (*Sus scrofa domesticus*), Specimen

Real bone specimen of the foot of a domestic pig. All bones from the heel bone to the four toes are fully prepared and connected in an anatomically correct manner.
1021064 \$165.00



Domestic Pig Foot (*Sus scrofa domesticus*), Plastinated Slice

The plastinated slice shows a section through a real pig's foot encapsulated in acrylic glass. The internal structure of the bones, the tissue structure and the arrangement of the tendons are very easily identifiable.
 Dimensions: approx. 20x10x2.3 cm³
 Weight: approx. 0.8 kg
1005382 \$210.00



Domestic Sheep (*Ovis aries*)

Taxonomy:

Class: Mammals
 Order: Even-toed ungulates
 Family: Bovids
 Diet: Herbivore
 Size: approx. 100 – 190 cm
 Weight: approx. 50 – 100 kg
 Age: 10 – 18 years
 Skeleton: approx. 215 individual bones

Dentition formula:

Number: 32
 Incisors (I): 0/3
 Canines (C): 0/1
 Premolars (P): 3/3
 Molars (M): 3/3



Domestic Sheep Skeleton (*Ovis aries*)

Prepared, real skeleton of a domestic sheep consisting of approximately 215 individual bones, which are rigidly connected to each other. It represents a typical example of the order of even-toed ungulates. You can choose between a male or a female item. Mounted on a base plate.

Length: approx. 100 – 120 cm
 Width: approx. 30 – 40 cm
 Height at withers: approx. 60 – 70 cm
 Weight: approx. 54 – 60 kg

♀ **Domestic Sheep Skeleton (*Ovis aries*), Female, Specimen 1021024**

♂ **Domestic Sheep Skeleton (*Ovis aries*), Male, Specimen 1021025**



Sheep Skull (*Ovis aries*), Replica

Fully developed sheep skull, cast from nature, with removable lower jaw. Made of unbreakable plastic.

Length: approx. 25 cm
1005105 \$280.00

Domestic Sheep Skull (*Ovis aries*)

Skull specimen of a domestic sheep made of real bones. Typical for a ruminant is the absence of the upper incisor and canine teeth and their replacement with a palatal plate. You have the choice of a male or a female skull.

Length: approx. 30 cm

♀ **Domestic Sheep Skull (*Ovis aries*), Female, Specimen 1021028**

♂ **Domestic Sheep Skull (*Ovis aries*), Male, Specimen 1021029**



Domestic Dog (*Canis lupus familiaris*)

Taxonomy:

Class: Mammals
Order: Predators
Family: Dogs
Diet: Carnivore
Size: approx. 20 – 85 cm
Weight: approx. 1 – 70 kg
Age: 7 – 18 years
Skeleton: approx. 280 individual bones

Dentition formula:

Number: 42
Incisors (I): 3/3
Canines (C): 1/1
Premolars (P): 4/4
Molars (M): 3/3



Dog Skeleton (*Canis lupus familiaris*)

The skeletons of domestic dogs are prepared from real bones and consist of approximately 280 individual bones that have been reassembled and mounted on a wooden base. You can choose between two variants. The bones of the rigidly mounted skeleton are firmly attached to each other for better stability. The flexibly mounted skeleton is particularly suitable for learning and understanding the locomotory system of a dog. The legs of the dog are movably attached to its torso. The dog skeleton is supplied in two sizes: M and L. The delivery time for size L may vary considerably from the average, depending on availability.

Size M:

Length: approx. 40 – 55 cm

Weight: approx. 4 – 4.5 kg

Size L:

Length: approx. 55 – 75 cm

Weight: approx. 4.5 – 5.5 kg

Dog Skeleton (*Canis lupus familiaris*), Size M, Specimen 1020988

Dog Skeleton (*Canis lupus familiaris*), Size L, Specimen 1020989

Dog Skeleton (*Canis lupus familiaris*), Size M, Flexibly Mounted, Specimen 1020990

Dog Skeleton (*Canis lupus familiaris*), Size L, Flexibly Mounted, Specimen 1020991



Dog Skull (*Canis lupus familiaris*)

Real skull of an adult domestic dog with movable jaw. You can choose between sizes M and L.

Skull length:

Size M: approx. 17.5 cm

Size L: approx. 22.5 cm

Dog Skull (*Canis lupus familiaris*), Size M, Specimen 1020994

Dog Skull (*Canis lupus familiaris*), Size L, Specimen 1020995 \$228.00

Dog Skull

(*Canis lupus familiaris*), Replica
Medium-sized dog skull, cast from nature, with removable lower jaw. Made of unbreakable plastic.
Length: approx. 19 cm
Weight: approx. 0,3 kg
1005104

Domestic Cat (*Felis catus*)

Taxonomy:

Class: Mammals
Order: Predators
Family: Cats
Diet: Carnivore
Size: approx. 50 – 60 cm
Weight: approx. 2 – 8 kg
Age: 10 – 18 years
Skeleton: Up to approx. 240 individual bones

Dentition formula:

Number: 30
Incisors (I): 3/3
Canines (C): 1/1
Premolars (P): 3/2
Molars (M): 1/1

Cat Skeleton (*Felis catus*)

Prepared skeleton of a real domestic cat consisting of more than 230 bones (depending on the length of tail) mounted on a wooden base. You can choose between two variants. The bones of the rigidly mounted skeleton are firmly attached to each other for better stability. The flexibly mounted skeleton is particularly suitable for learning and understanding the locomotory system of a cat.

Length: approx. 50 – 70 cm

Width: approx. 27 – 35 cm

Height: approx. 40 – 60 cm

Weight: approx. 3.6 – 4.5 kg

Cat Skeleton (*Felis catus*), Specimen 1020969

Cat Skeleton (*Felis catus*), Flexibly Mounted, Specimen 1020970 \$1,235.00

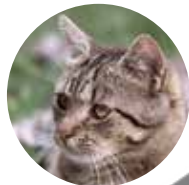

Cat Skull (*Felis catus*), Specimen

Real skull of an adult domestic cat with movable jaw. The shape of the skull may vary depending on the breed.

Length: approx. 10 cm

1020972 \$192.00

Domestic Rabbit (*Oryctolagus cuniculus* var. *domestica*)

Taxonomy:

Class: Mammals
 Order: Lagomorphs
 Family: Leporidae
 Diet: Herbivore (browser)
 Size: approx. 20 – 45 cm
 Weight: approx. 1 – 4 kg
 Age: approx. 10 years
 Skeleton: approx. 210 individual bones

Dentition formula:

Number: 28
 Incisors (I): 2/1
 Canines (C): 0/0
 Premolars (P): 3/2
 Molars (M): 3/3



Rabbit Skull (*Oryctolagus cuniculus* var. *domestica*), Specimen

Bone specimen of the skull of an adult domestic rabbit with movable jaw. The typical features of a rabbit skull, fine bone lamellae, are clearly visible.

Length: approx. 10 cm
1020987 \$250.00



Rabbit Skeleton (*Oryctolagus cuniculus* var. *domestica*), Specimen

Prepared, real skeleton of an adult domestic rabbit consisting of about 210 individual bones, which are rigidly connected to each other. It represents a typical example of the order of lagomorphs. Mounted on a base plate.

Dimensions: approx. 48x11x27 cm³

Weight: approx. 3 kg
1020985 \$1,185.00

Mouse and Mouse Skeleton (*Mus musculus*) in Display Case, Specimens

High-quality, lifelike and anatomically correct specimens of a house mouse and of a mouse skeleton, which have been prepared by technicians who have been trained at the highest level. Only in this way is it possible to ensure the durability of the specimens. In display case.

Dimensions: approx. 16x11x10 cm³

Weight: approx. 1 kg
1021039 \$537.00



Mouse (*Mus musculus*)

Taxonomy:

Class: Mammals
 Order: Rodents
 Family: Murids
 Diet: Omnivore
 Size: approx. 5 – 10 cm
 Weight: approx. 20 – 30 g
 Age: approx. 1 – 3 years
 Skeleton: approx. 145 individual bones

Dentition formula:

Number: 16
 Incisors (I): 1/1
 Canines (C): 0/0
 Premolars (P): 0/0
 Molars (M): 3/3



Rat (*Rattus rattus*)

Taxonomy:

Class: Mammals
 Order: Rodents
 Family: Murids
 Diet: Herbivore
 Size: approx. 10 – 28 cm
 Weight: approx. 100 – 450 g
 Age: approx. 1 – 3 years
 Skeleton: approx. 145 individual bones

Dentition formula:

Number: 16
 Incisors (I): 1/1
 Canines (C): 0/0
 Premolars (P): 0/0
 Molars (M): 3/3



Rat (*Rattus norvegicus*), Plastinated Slice (not shown)

Longitudinal section through a real brown rat encapsulated in acrylic glass. The plastinate enables the observation of real anatomy down to the finest detail as well as the interaction of the systems and the structure of the body.

Dimensions: approx. 20x16x2.3 cm³

Weight: approx. 1.1 kg
1005385

Rat Skeleton (*Rattus rattus*), Specimen

Bone specimen of a real rat skeleton consisting of approximately 145 individual bones, rigidly mounted on a base plate.

Length: approx. 30x12x10 cm³

Weight: approx. 1.2 kg
1021036 \$580.00



Rat Skull (*Rattus rattus*), Specimen

Prepared real skull of an adult black rat.

Length: approx. 3.5 cm

1021038 \$130.00



Chicken (*Gallus gallus domesticus*)

Taxonomy:

Class: Birds
 Order: Landfowl
 Family: Phasianids
 Diet: Omnivore
 Size: approx. 30 – 40 cm
 Weight: approx. 2 – 5 kg
 Age: approx. 4 – 8 years



Chicken Skeleton (*Gallus gallus domesticus*), Specimen

Our anatomical skeleton model of a domestic chicken consists of natural, prepared bones, which are rigidly connected to each other for better stability. It represents a typical example of a bird. The chicken skeleton is excellently suited to anatomical studies or comparative anatomy because even the smallest chicken bones are clearly visible. Mounted on a base plate.
 Length: approx. 50 – 60 cm
 Width: approx. 40 – 60 cm
 Height: approx. 60 – 70 cm
 Weight: approx. 3.5 – 4.5 kg
1020966 \$660.00



Chicken Skull (*Gallus gallus domesticus*), Specimen

Bone preparation of a real chicken skull. A particularly striking feature of the skull is its relatively large eye sockets.
 Length: approx. 6 cm
1020968



Chick (*Gallus gallus domesticus*), Plastinated Slice

Longitudinal section through a real chick encapsulated in acrylic glass. The plastinates are created using high-quality plastics with specific refractive indices that are tailored to suit the relevant tissue. These plastics permeate the tissue during the manufacturing process and make it transparent.
 Dimensions: approx. 20x16x2.3 cm³
 Weight: approx. 1.7 kg
1005383



Pigeon Skeleton (*Columba livia domestica*), Specimen

Pigeons skeleton using real, prepared bones, which are rigidly connected with each other for stability. It is particularly suitable for studying the special features of the bird skeleton. Rigidly mounted on a base plate.
 Height: approx. 60 – 70 cm
 Width: approx. 40 – 60 cm
 Length: approx. 50 – 60 cm
 Weight: approx. 3.5 – 4.5 kg
1020982 \$468.00



Pigeon (*Columba livia domestica*)

Taxonomy:

Class: Birds
 Order: Columbiformes
 Family: Columbids
 Diet: Omnivore
 Size: approx. 20 – 35 cm
 Weight: approx. 180 – 350 g
 Age: approx. 1 – 4 years



Pigeon and Pigeon Skeleton (*Columba livia domestica*), in Display Case, Specimens

Bone preparation of a pigeon skeleton and, for comparison, a pigeon that is prepared to be lifelike and covered with real feathers. The longevity of the specimen is assured thanks to the first-class preparation work. In display case.
 Dimensions: approx. 35x25x25 cm³
 Weight: approx. 3 kg
1021040 \$747.00



Pigeon Skull (*Columba livia domestica*), Specimen

Real, prepared pigeon skull. A striking feature of the skull is its relatively large eye sockets.
 Length: approx. 5.5 cm
1020984



Pigeon Wings and Feathers (*Columba palumbus*), Specimen

Prepared, real pigeon wing and feathers from a wood pigeon in a display case. Wing features and feathers are labelled in English. Wing divided to show primary and secondary flights.
Types of feather:
 Down, flight feathers, tail feathers and coverts.
 Dimensions: approx. 40x30x4 cm³
 Weight: approx. 1.4 kg
1002557 \$373.00

Duck Skull (*Anas platyrhynchos domestica*), Specimen

Prepared, real skull of an adult domestic duck. Rigidly mounted.

Length: approx. 11 cm
1020981



Duck (*Anas platyrhynchos domestica*)

Taxonomy:

Class: Birds
 Order: Anseriformes
 Family: Anatids
 Diet: Omnivore
 Size: approx. 40 – 55 cm
 Weight: approx. 1 – 1.5 kg
 Age: 5 – 10 years



Duck Skeleton (*Anas platyrhynchos domestica*), Specimen

Prepared, real skeleton of an adult domestic duck. It is the largest and most commonly occurring swimming duck and represents a typical example of the order of anseriformes. The bones are rigidly connected with each other for stability. Rigidly mounted on a base plate.

Length: approx. 45 – 60 cm
 Width: approx. 20 – 25 cm
 Height: approx. 40 – 50 cm
 Weight: approx. 3.5 – 4.5 kg
1020979 \$675.00

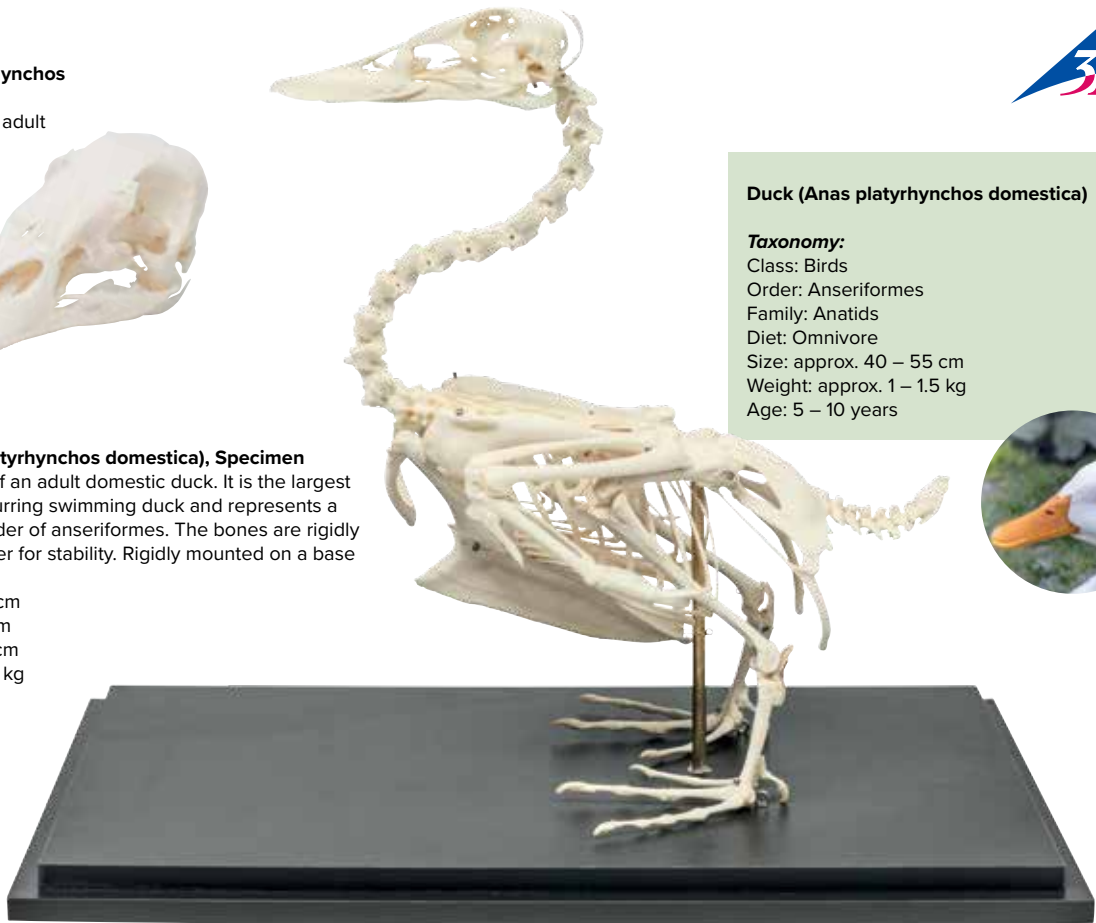

Goose (*Anser anser domesticus*)

Taxonomy:

Class: Birds
 Order: Anseriformes
 Family: Anatids
 Diet: Omnivore
 Size: approx. 80 – 90 cm
 Weight: approx. 6 – 10 kg
 Age: 10 – 20 years



Goose Skeleton (*Anser anser domesticus*), Specimen

Prepared, real skeleton of an adult domestic goose. Even the smallest bones are visible on this goose skeleton. Well suited to comparative anatomy. Rigidly mounted on a base plate.

Dimensions: approx. 40x22x45 cm³
 Weight: approx. 5 kg
1021033 \$767.00



Goose Skull (*Anser anser domesticus*), Specimen

Professionally prepared, real skull of an adult domestic goose with all the features typical of a goose's head. Rigidly mounted.

Length: approx. 13.5 cm
1021035

Carp Skeleton (Cyprinus carpio), Specimen

Complete, real skeleton of a carp, carefully prepared, reassembled and mounted on a base plate. It represents a typical example of the order of cypriniformes. The specimen is particularly suitable for the study of the structure of bony fish. The following typical features of bony fish are mounted separately:

- Complete gill with gill arches, filaments and rakers
- Pharyngeal bone with teeth
- Typical cycloid scales of the cypriniformes with growth rings
- Thoracic vertebrae with neural and pleural arches

Length: approx. 40 – 50 cm
Width: approx. 10 – 15 cm
Height: approx. 10 – 20 cm
Weight: approx. 1.5 – 2.0 kg
1020962 \$610.00

Carp (Cyprinus carpio)

Taxonomy:

Class: Ray-finned fishes
Order: Cypriniformes
Family: Cyprinids
Diet: Primarily insectivore
Size: approx. 30 – 120 cm
Weight: approx. 5 – 25 kg
Age: approx. 10 – 40 years
Pharyngeal dentition formula: 1.1.3 – 3.1.1



**Carp Head (Cyprinus carpio), Specimen (not shown)
1020963**

European Catfish (Silurus glanis)

Taxonomy:

Class: Ray-finned fishes
Order: Catfishes
Family: Silurids
Diet: Mainly fish-eater
Size: Up to 300 cm
Weight: Up to 60 kg
Age: approx. 20 – 80 years



Skeleton of European Catfish (Silurus glanis), Specimen

The professionally prepared skeleton of a European catfish shows the typical features of a catfish: the elongated body with its large, wide head as well as the barbels around its mouth. The European catfish is the heaviest and largest freshwater fish that is native to Europe.

Length: approx. 65 – 75 cm
Width: approx. 30 – 40 cm
Height: approx. 25 – 35 cm
Weight: approx. 1.5 kg
1020964



Catfish Head (Silurus glanis), Specimen

This specimen of the head of a European catfish, consisting of real bones, shows the broad, strong and downturned mouth on a flattened head with barbels that is typical of catfishes. It is studded with many small teeth, which are located at the outer edge of the mouth.

1020965

Trout (Salmonidae)

Taxonomy:

Class: Ray-finned fishes
Order: Salmoniformes
Family: Salmonids
Diet: Insectivore / fish-eater
Size: 12 – 150 cm
Weight: Up to 40 kg
Age: approx. 6 – 17 years



Trout (Salmonidae), Plastinated Slice

Longitudinal section through a real salmonid, prepared and encapsulated in acrylic glass. The plastinated slice is particularly suitable for the study of the internal anatomical structures of fishes and their functional relationships.

Dimensions: approx. 20x16x2.3 cm³
Weight: approx. 0.7 kg
1005384



Limbs of Different Mammals (Mammalia)

The dissected real limbs enable scientific comparison of the anatomy of the front or rear legs of selected mammals and allow conclusions to be drawn about their walking and running behaviour. In order to be able to compare human with animal, an original plastic cast of a human hand or human foot is included in each case. This makes it possible to explain clearly e.g. the difference between plantigrades, digitigrades and unguligrades. The individual limbs are supplied as separate items and must be mounted on a wooden base. Assembly instructions are included.



Hind Legs of Different Mammals (Mammalia)

Included are four real bone specimens: the hind leg of a dog and the hind foot of a horse, a cow and a pig respectively, as well as an original plastic cast of a human foot.

1021042

Structure of a Bird and a Mammal Bone, Specimen

Longitudinal and cross section of a prepared, real bird bone and mammal bone respectively, mounted on a base plate. The product illustrates the difference between the long bones of a bird and a mammal. Bird bones are hollow inside and have large air chambers. Mammal bones, in contrast, are filled with bone marrow and spongy tissue.

Including display case for protection.

1021045



Tooth Types and Shapes of Different Mammals (Mammalia)

A comparison of the different tooth shapes and types allows conclusions to be drawn about the various sources of nutrition as well as the feeding and hunting behaviour of omnivores (pigs, dogs), carnivores (cats) and herbivores (cows, rabbits, rats).

Tooth Types of Different Mammals (Mammalia), Deluxe Version

The deluxe version of this article contains a half set of prepared, real teeth from the upper and lower jaw of a rabbit, a cat and a pig respectively. Mounted on a base plate.

1021046



Front Legs of Different Mammals (Mammalia)

Included are four real bone specimens: the front leg of a dog and the front foot of a horse, a cow and a pig respectively, as well as an original plastic cast of a human hand.

1021043

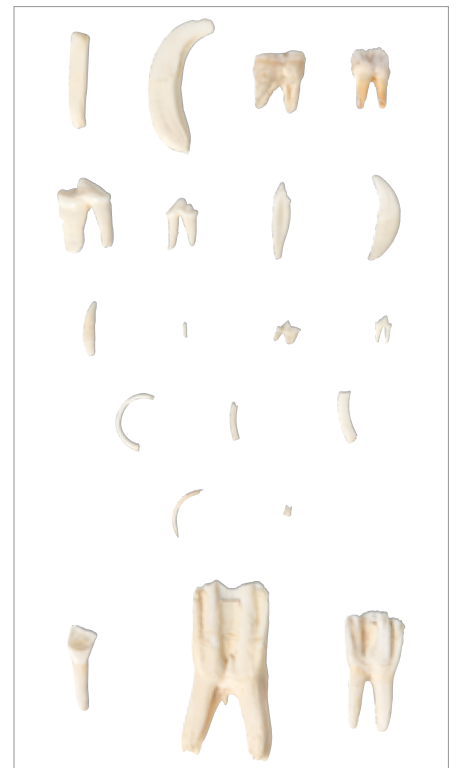

Tooth Types of Different Mammals (Mammalia)

The product includes one example of each of the tooth types, giving a total of 20 prepared, real teeth.

Pig, dog, cat: one incisor, one canine, one premolar and one molar tooth
Cow, rabbit: one incisor, one premolar and one molar tooth

Rat: one incisor and one molar tooth

1021044



➤ Perfect for students and teachers!
3B Scientific® Microscopes:
 Basic, intermediate, advanced, and
 research microscopes.



➤ Intermediate Microscope

Binocular Microscope

Head: Siedentopf binocular head, 30° inclined and 360° rotation
Eyepieces: Paired 10x DIN wide-field eyepieces
Objectives: Triple nosepiece DIN achromatic objectives
 4x, 10x, 40xR, 100xR (oil)
Condenser: Abbe N.A.1.25 spiral type, iris diaphragm, filters and filter holder
Stage: Plain stage 127 x 132 mm with spring clips
Illumination: Built-in fluorescent bulb, 5W
3004968 \$282.00

➤ Advanced Microscope

Construction:

The coaxial focusing via metal rack & pinion with ball bearing guide provides stable and smooth movement. The focusing stop is adjustable to prevent damage to slides and objectives.

Objectives: Quadruple nosepiece; DIN achromatic objectives
 4x, 10x, 40xR, 100xR (oil)
Stage: Built-in mechanical stage 125 x 130 mm with specimen clamp.
 Coaxial knobs for X-direction and Y-direction with range
 70 x 30 mm.
Condenser: Abbe condenser NA1.25 with iris diaphragm; Filter holder is
 focusable by rack and pinion
Illumination: Built-in illuminator with fluorescent bulb 5W, main power 115V

Monocular Microscope

3007245 \$224.00

Binocular Microscope

3007246 \$282.00

Research microscope

Monocular Microscope

The coaxial focusing with ball-bearing guide works accurately and smoothly over the focusing range. It comes with built-in tension adjustment. The focus stop is adjustable.

Focusing range: 15 mm. Fine focusing graduation: 0.002 mm

Objectives: Quadruple nose piece; DIN plan achromatic objectives 4x, 10x, 40xR, 100xR (oil)

Stage: Built-in mechanical stage 132mm x 145mm with specimen holder offers a moving range of 50 x 76mm. It is controlled by coaxial knobs at low position for comfortable operation.

Condenser: Abbe NA1.25 with iris diaphragm & filter holder is focusable by rack and pinion

Illumination: Built-in electrical illuminator with a halogen bulb 20W/6V offers bright and even illumination over the whole field of view, and the brightness is adjustable continuously

3007247 \$315.00



Optional Equipment for Research Microscopes:
Condenser (Wet) 3007266 \$105.00

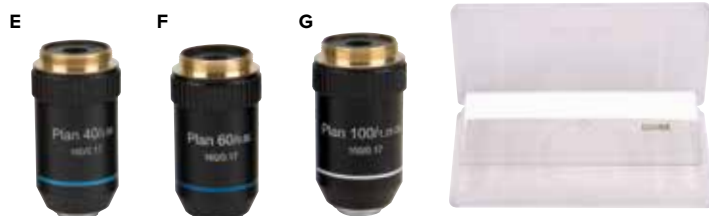
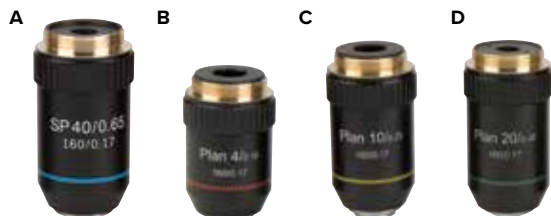

Upgrades for basic, intermediate, advanced & research microscopes:

Widefield-eyepieces (not shown)

| | | |
|---------------------------|---------|---------|
| WF 10x-18 mm with pointer | 3007253 | \$14.00 |
| WF 10x-18 mm with scale | 3007254 | \$24.00 |

Semi-plan Achromatic Objectives

| | | |
|---------|---------|---------|
| A. 40xR | 3007257 | \$35.00 |
|---------|---------|---------|

Plan Achromatic Objectives

| | | |
|---------------|---------|---------|
| B. 4x | 3007259 | \$19.00 |
| C. 10x | 3007260 | \$35.00 |
| D. 20xR | 3007261 | \$54.00 |
| E. 40xR | 3007262 | \$66.00 |
| F. 60xR | 3007263 | \$89.00 |
| G. 100xR(oil) | 3007264 | \$89.00 |

Micrometer Slide

| | | |
|---|---------|---------|
| H. Size: 76 x 26 mm (1mm/100div./0.01 mm) | 3007267 | \$31.00 |
|---|---------|---------|



➤ **Bring Science to life with these hands-on kits! Teacher's Manual and student study guides included.**

DNA/Chromosome Staining

Prepare your own squashed stained slide and be able to identify the phases of plant mitosis and chromosomal development. With the DNA/Chromosome Staining Kit, students will be able to prepare, stain and mount slides using specifically prepared onion root tips. Kit contains enough material for 15 groups. Teacher's Manual and Student Guide copymasters are included. See online for included materials.

3004929 \$59.99



DNA Extraction

In this lab students will learn the history of the discovery of DNA and DNA structure. Understand the nature of genetic inheritance and the role of DNA and proteins in genetic expression while using biological detergents, enzymes, and ethanol to isolate DNA from plant material. You need to supply the plant material. Kit contains enough materials for 15 groups. Teacher's Manual and Student Study Guide copymasters are included. See online for included materials.

3007471 \$38.15



Acid Rain and the Environment: Acidity and Plant Growth

The problem of acid rain is quite often associated with its effects on aquatic systems. Unfortunately, acid rain can also have devastating effects on terrestrial environments as well. In this activity, students will examine the detrimental effects of acidic conditions on plants. Plants will be grown under normal soil conditions, mildly acidic soil conditions, and very acidic soil conditions. Through physical observation, students will determine if the acidity has any impact on the growth of the plant. Kit contains enough materials for 15 groups. See online for included materials.

3007480 \$69.00



Osmosis and Diffusion Lab

This lab allows you to learn about two forms of passive transport: diffusion and osmosis. You will compare and contrast similarities and differences in the processes of diffusion and osmosis. Use a colorimetric test to demonstrate the movement of a solute across a semi-permeable membrane. Set up an environment likely to facilitate osmosis and gather data to determine whether or not osmosis may have occurred. Kit contains enough materials for 15 groups. Teacher's Manual and Student Study Guide copymasters are included. See online for included materials.

3004930 \$52.50



Diffusion and Cell Size

Why are cells microscopic? The answer relates to the needs for the cell to effectively move materials in and remove waste. In this activity, students will create simulated cells (agar blocks) of different sizes and examine how effectively a substance is able to diffuse into the cell in a set period of time. A special indicator in the cells will allow students to visualize the degree of diffusion. The results will clearly display the fact that a smaller volume creates a more favorable condition for the exchange of material across a cell membrane. Kit contains enough materials for 15 groups of students. Teacher's Manual and Student Study Guide copymasters are included. See online for included materials.

3004932 \$46.50



Kidneys and Blood Filtration

Learn the role of the kidney in blood filtration and waste removal along with the many functional tasks performed by nephrons, as well as nephron structure. Students will create an artificial kidney model to filter simulated blood. This will allow them to visually determine if filtration of the simulated blood may or may not have occurred. Chemically test the resulting filtrate to detect any possible waste material that may have been removed by the kidney. Kit contains enough materials for 15 groups. Teacher's Manual and Student Study Guide copymasters are included. See online for included materials.

3007873 \$49.65



Urinalysis Using Simulated Urine

Urinalysis, one of the oldest medical diagnostic tests performed, is to this day still one of the most common. In this activity, students will use simulated urine to avoid the unpleasantness of using the real thing while still performing actual tests used on real urine samples. Students will examine the simulated urine for factors such as pH, color, clarity, as well as test for the presence or absence of proteins, glucose and calcium. The students will then examine the samples microscopically to determine if crystals may be present in any of the samples. Kit contains enough materials for 15 groups of students. Teacher's Manual and Student Guide copymasters are included. See online for included materials.

3007473 \$61.50



Gun Shot Residue Presumptive Test Kit

This is a two part test to determine whether a surface has been exposed to a discharged firearm. A rapid color change takes place to verify the presence of nitrates and lead in this gunshot residue test kit. Each kit contains instructions and enough materials for 30 tests for gun shot residue. See online for included materials.

3007859 \$35.50

➤ More kits available at 3bscientific.com!



Presumptive Blood Test Kit

Test for the presence of blood on materials using phenolphthalein. The Presumptive Blood test will not distinguish between animal and human blood. Further serology tests are needed for this type of blood distinction. Included in the Presumptive Blood test are instructions, blood standard and reagents to complete 30 tests. See online for included materials.

3007468 \$21.25



Forensic Chemistry of Document Analysis

The Forensic Chemistry of Document Analysis kit sets up the following crime to solve:

The school library's computers have been stolen. Left behind was a ransom note demanding money. Help solve the crime using thin-layer chromatography to separate the ink on the ransom note and ink found in markers tied to possible suspects. It may be possible to provide evidence as to whether or not the ransom note could have been written with a particular marker. Kit contains enough material for 15 groups. Teacher's Manual and Student Guide copymasters are included. See online for included materials.

3004918 \$97.00



Forensic Chemistry of Blood Types

Blood typing is a method of classifying blood based on the presence or absence of specific proteins, called antigens, on the surface of red blood cells. Blood type, an inherited characteristic, is valuable to know in that it affects medical procedures, such as surgery and transfusions, paternity testing, as well as serving as evidence in criminal investigations. Determining blood type can help provide supporting evidence or eliminate a possible suspect's involvement in a crime. This Forensic Chemistry of Blood Types activity includes a Teachers Manual and Student Guide and Analysis copymasters. There is enough material for 15 groups of students. See online for included materials.

56607 \$44.65



Enzymes and The Process of Digestion

All the food in the world is of no use if the human body does not have the ability to extract necessary nutrients from it. With this activity, students will be able to expose three nutrients (carbohydrates, proteins and lipids) to different digestive enzymes. These samples will be compared to nutrients to which no enzymes are added and chemical tests will be used to determine if the enzymes were effective in digesting the compounds. Upon completion, students will not only understand the importance of the digestive system but also the vital role enzymes play in releasing nutrients from food and converting them to a form usable by the body. Kit contains enough materials for 15 groups. Teacher's manual and student guide copymasters are included.

3007877 \$63.00



Environmental Chemistry: Acid Rain, Weathering, and Erosion

Acid rain is a term used generically to describe any type of acidic moisture, be it rain, snow, or fog. Acid rain can have devastating effects on not only aquatic ecosystems but also terrestrial areas. Acid rain not only affects naturally-occurring surfaces, such as exposed rocky surfaces of mountainous regions, but also human-made surfaces as well. Different stone and metal substances used in the construction of buildings, statues, monuments, etc. may all be affected by acid rain. The rates of erosion and weathering may increase rapidly depending on the degree of acidity in the precipitation. In this activity, students expose many rock materials and metals, both naturally-occurring and common in construction, to an acidic environment and examine the reaction of these materials in contrast to the same materials exposed to "normal" rain (tap water). Kit contains enough materials for 15 groups. Teacher's Manual and Student Study Guide copymasters are included. See online for included materials.

3007479 \$53.65



Green Chemistry: Electrochemical Remediation of Wastewater

Water pollution is one of the largest threats facing the global population. Water is a finite resource. Once polluted, it cannot be set aside in the hopes that the environment will "make" new, clean water. One procedure often employed to treat wastewater is coagulation/flocculation. While the coagulation/flocculation procedure in wastewater treatment is effective, it involves the addition of chemical components to the water being treated. Recently, a great deal of attention has been given to less traditional alternatives to the typical process of coagulation/flocculation. One such approach receiving a good deal of attention is a process called electrocoagulation. Electrocoagulation is a coagulation process carried out by an electrical charge. Kit contains enough materials for 15 groups of students. Teacher's manual and student study guide copymasters are included. See online for included materials.

3007476 \$64.79



Green Chemistry: The Production of Biodiesel

In this activity, students will be performing a two-phase process to produce small batches of crude biodiesel. The crude biodiesel produced is of sufficient quality for use in the demonstration of the burning qualities of both biodiesel and vegetable oil. Included is an optional small-scale exercise where the students will use a washing procedure to experience the full process of producing biodiesel to meet quality levels necessary for use in vehicles. Kit contains enough materials for 15 groups of students. Teacher's manual and student guide copymasters are included. See online for included materials.

3007475 \$63.95



EARTH SCIENCE

The earth is the only planet known so far on which higher forms of life exist. Many factors, including the inner structure and the outer form, contribute to this. To better understand our environment, we have developed interesting new products, working with renowned experts, and have summarized them on the following pages.

PLATE TECTONICS & VOLCANIC ACTIVITY



Relief Globe

Tabletop globe with lighting on a metal-reinforced plastic stand with double-image map and tactile 3D relief of mountain ranges. When the globe is not lit up, it shows a physical map of the earth. When it is lit up, the current political position is shown with a contrasting delimitation of the countries and their borders. Labels in English.

Technical information:

Diameter: 30 cm
 Total height: 43 cm
 Meridian: Plastic, transparent
 Power supply: 230 V, max. 25
 Lamp socket: E14

1018440 \$157.00

Vertical circle:

Calibration: 90°-0°-90°
 Scale value: 5°
 Dimensions: 80 x 65 x 20 mm³
 Weight: Approx. 240 g including leather bag



Mid-Atlantic Spine

This model shows the shaped course in 3D of the volcanic mountain range produced by tectonic shifts in the Atlantic Ocean.

Size at the Equator: 1:320.000.000
 Material: PVC
 Dimensions: 64 x 48 x 8 cm
 Weight: 6.5 kg

1017594 \$513.00

Geological Compass

Surface areas and linear measurements in space can be measured in one step. The angle is measured laterally on a vertical circle, and the direction is measured with an integrated Pendel clinometer. This structural compass is ideally suited to working in the field. The circular level, the mirror and the pelorus are also integrated. Oscillation time of themagnetic needle: 30 - 60 seconds. Includes a leather bag with a belt clip, and a special tool to adjust the compass rose and the lid hinge.

1018441 \$195.00

Pendel clinometer:
 Calibration: 90°-0°-90°
 Scale value: 1°

Horizontal circle:
 Calibration: 0-360°
 Scale value: 1°

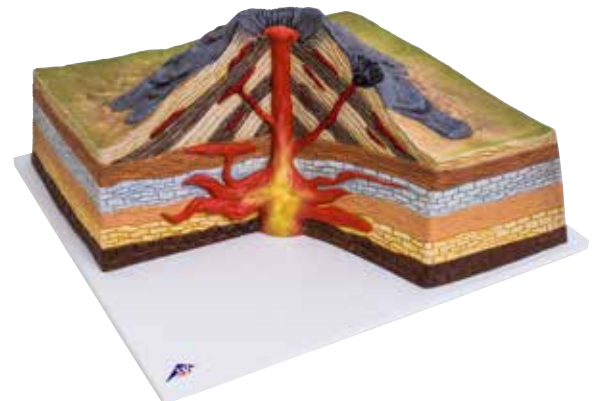

Stratovolcano

This hand-painted model shows the inside of a stratovolcano with the path of liquid magma to earth's surface.

Material: PVC
 Dimensions: 47 x 35 x 19 cm
 Weight: 2.4 kg

1017595 \$327.00

ROCKS & MINERALS

› Minerals and rock collections

The collections contain 24 frequently occurring examples of various stone and mineral groups. The examples are approx.

3 x 3 x 3 cm to 5 x 5 x 5 cm in size, and come in a robust box that includes numbering, labels and an information booklet.



Collection of 24 volcanic rocks and minerals

The collection contains volcanic rocks and minerals.

The collection contains:

1. Volcanic rocks: basalt, phonolite, pitchstone, rhyolite
2. Lava: Lava from Vesuvius, basaltic lava and rhyolitic lava
3. Pyroclasts: lapilli, volcanic ash, pumice stone
4. Minerals: anorthite, anorthoclase, augite, cristobalite, hauyne, leucite, natrolite, nepheline, pickeringite, sanidine, sulphur, thaumasite, tridymite, obsidian

1018442 \$182.00



Collection of 24 rocks

The collection contains frequently occurring examples of metamorphic, sedimentary and magmatic rocks as well as important examples of industrial rocks.

The collection contains:

1. Magmatic rocks, plutonites: foyaitite, gabbro, granite, granodiorite, larvikite and monzonite
2. Magmatic rocks, vulcanites: basalt, pumice stone, phonolite, rhyolite
3. Sedimentary rocks: breccia, dolomite, gypsum, limestone, chalk, quartzite and sandstone
4. Metamorphic rocks: amphibolite, eclogite, mica schist, gneiss, marble, phyllite and serpentinite

1018443 \$182.00



Collection of 24 minerals

The collection contains examples of ten classes of minerals: elements, sulphides, halogenides, oxides, carbonates, borates, sulphates, silicates, phosphates and organic compounds.

The collection contains:

1. Elements: graphite and sulphur
2. Sulphides: bournonite, galenite and pyrite
3. Halogenides: fluorite and halite
4. Oxides: hematite, quartz and rutile
5. Carbonates: calcite and dolomite
6. Borates: ludwigite
7. Sulphates: barite, coelestine and gypsum
8. Phosphates, arsenates and vanadates: apatite and vanadite
9. Silicates and germanates: actinolite, amonite, muscovite, sodalite and talk
10. Organic compound: copal

1018444 \$182.00



Set of three volcanic rocks

Set of three vulcanite rocks consisting of three little bags, each containing ten pieces of either lava rock, obsidian or pumice stone.

1018462 \$78.00

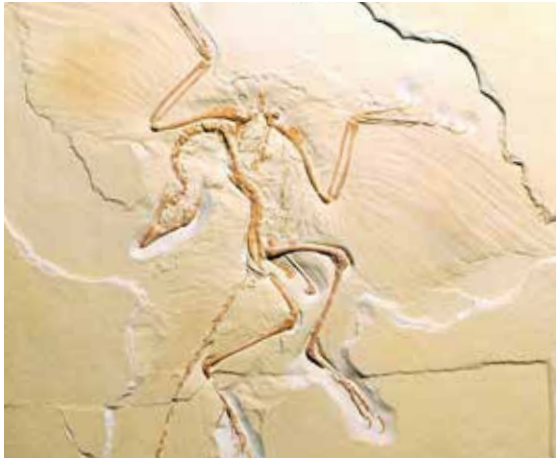

Archaeopteryx lithographica

Liquid wood mold of the well-known archaeopteryx lithographica fossil from Bavaria. The clear avian characteristics, flight feathers and furcula, as well as reptilian characteristics, the bony tail and front claws, are recognisable. It is therefore considered a transitional form of both species. The fossil is considered one of the few complete findings of the archaeopteryx lithographica, which lived around 150-200 million years ago.

Weight: 1.8 kg
 Height: 47.5 cm
 Width: 40 cm
 Length: 1.5 cm
1018509 \$569.00

Ammonite, model
 An exact and scientifically-based reproduction of what an ammonite may have looked like. The model shows all the important organs on the head such as the eyes, the tentacles, the funnel and the jaw that resembles the beak of a parrot.
 Length: 15 cm
 Width: 9 cm
 Height: 8 cm
 Weight: 121 g
1018515 \$34.00

Ammonite, polished
 Polished shell of a fossilised ammonite from Madagascar.
 Size: 5 - 9 cm
 Period: Cretaceous (~ 90 Mya)
1018511 \$63.00

Ammonite, 2 polished halves
 Polished shell divided into two halves of a fossilised ammonite from Madagascar.
 Size: 8 - 12 cm
 Period: Cretaceous (~ 90 Mya)
1018510 \$74.00

> An introduction to Paleontology

Stratigraphic collections

These collections contain carefully selected animal and plant fossils from all the important groups that are representative of certain geological time periods. The fossils are placed in chronological order and gives an overview of the development of life from the Precambrian to the Triassic period. Each item is stored individually in boxes with a label, date and details of where it was found. They come in a wooden box with a detailed booklet in English, German and French. The items delivered may vary depending on availability. We will ensure that we provide at least one example from each period.

Stratigraphic collection 20 fossils 1018512 \$574.00
Stratigraphic collection 40 fossils 1018513 \$981.00



Examples from the collection:



Name: Hexacorallia: *Pattalophyllia sinuosa*
 Age: Tertiary, Eocene: 56-38 Mya
 Place found: Pyrenees, Spain

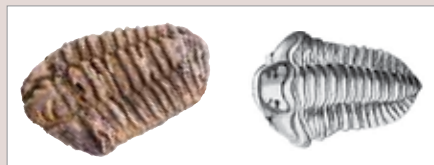

Name: Trilobite: *Diacalymene ouzrequi*
 Age: Ordovician: Middle Ordovician
 485.4-443.4 Mya
 Place found: Alnif, Morocco

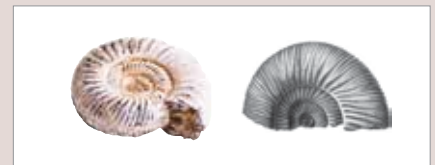

Name: Ammonite: *Divisosphinctes (Perisphinctes) besairiei*
 Age: Jurassic, Late Jurassic, Oxfordium: 163.5-157.3 Mya
 Place found: Sakaraha, Madagascar

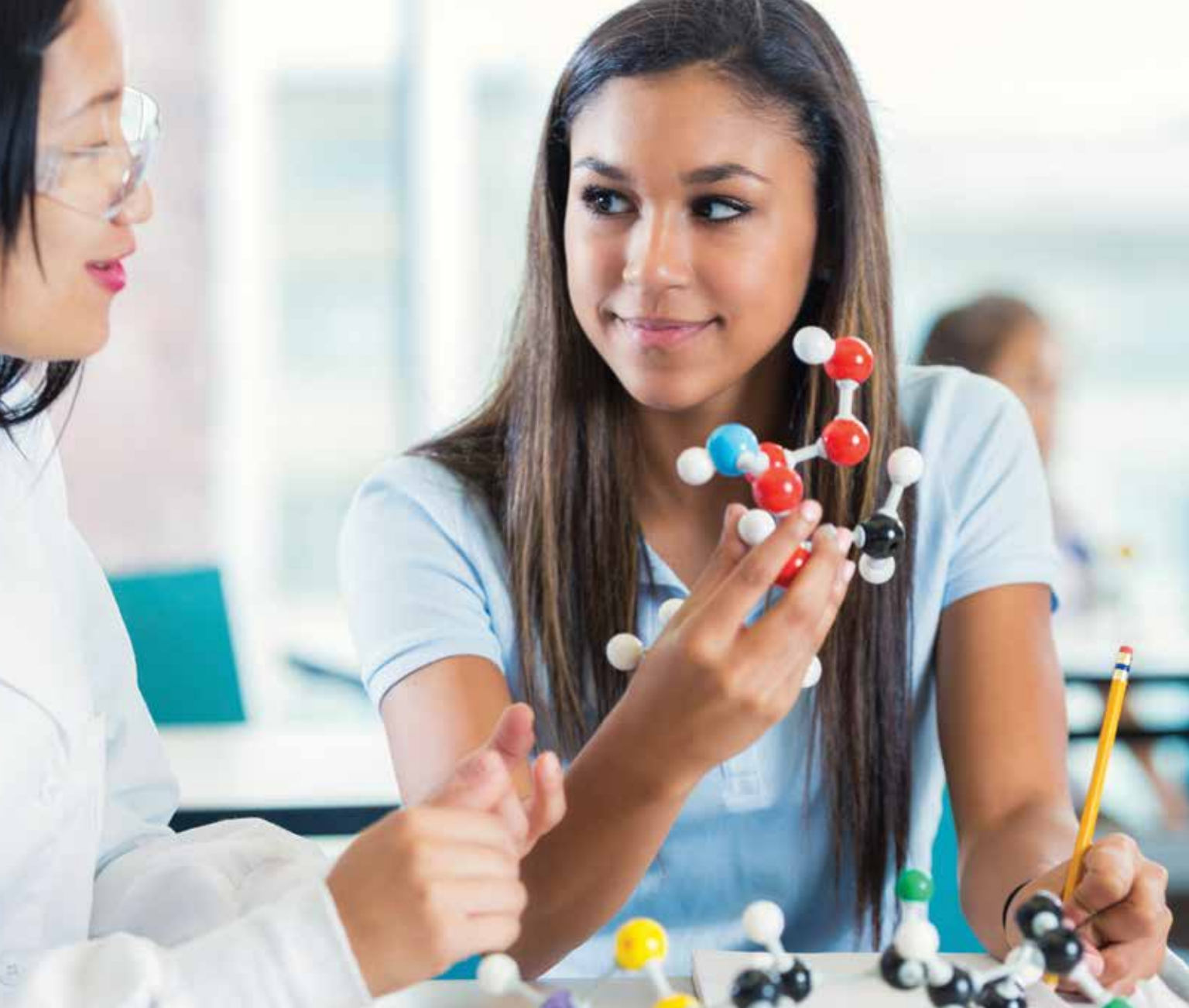

CHEMISTRY

Students will gain hands-on experience in the fundamentals of chemistry by constructing models of organic and inorganic structures representing numerous chemicals, molecules, crystals and other compounds. Build hundreds of different structures while gaining an understanding of elemental particles.



Interactive Atomic Model According to Bohr - Teacher Edition

Interactive atomic model class set with 8 student training models and 2 magnetic demonstration atoms functions and structures for your physics, chemistry and biology classes. With this completely magnetic demonstration atom you will be able to clearly and quite easily explain Bohr's atomic model to your students on the blackboard. Using the training atom your students will be able to construct their own atoms, isotopes, and even ions.

1005319 \$444.00

Interactive Atomic Model According to Bohr - Student Edition

This student model applies tactile learning to chemistry, physics and biology! This excellent model greatly simplifies the understanding of Bohr's model of the atom. The base and lid double as the nucleus of an atom surrounded by its' electron orbits. Visualize the protons, neutrons and electrons which provides a greater understanding of the overall charge of an atom. When you're finished conveniently store the protons, neutrons and electrons inside the model at the end of studying. All the components needed to create atoms, isotopes, ions, noble gas configurations, covalent bonds, and more are provided.

1005320 \$59.00



The Blue Marble Vinyl Periodic Chart

It's vinyl, it's huge! Go ahead, just try and tear it, almost as indestructible as the elements themselves. PLUS it's two posters in one. We took our most popular poster (The Ultimate Periodic Chart) and printed another Periodic Chart on the back side with 103 gorgeous color photos of the minerals that provide the elements we use.

36" x 54"

3005201 \$21.00

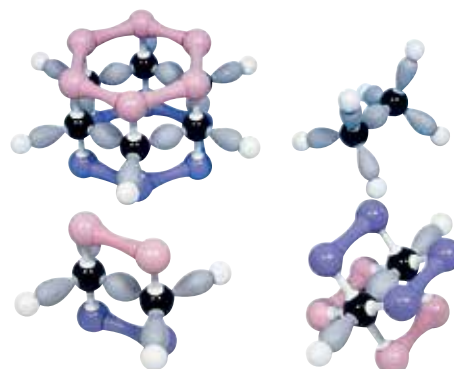

Molyorbital™ Molecular Organic Structures Set

This 4 model collection set contains sufficient parts to make benzene, ethane, ethene, and ethyne. Shows sigma and pi bonding orbitals, and concepts of hybridization and delocalization. Top row: Benzene, Ethane; bottom row: Ethene, Ethyne.

Contents:

- 12 Carbon
- 18 Hydrogen
- 9 Carbon-carbon (oval shaped)
- 18 Carbon-hydrogen (pear shaped) sigma bonds
- 9 pi-bonds (21 pink and 21 purple pieces)

1005292 \$55.00

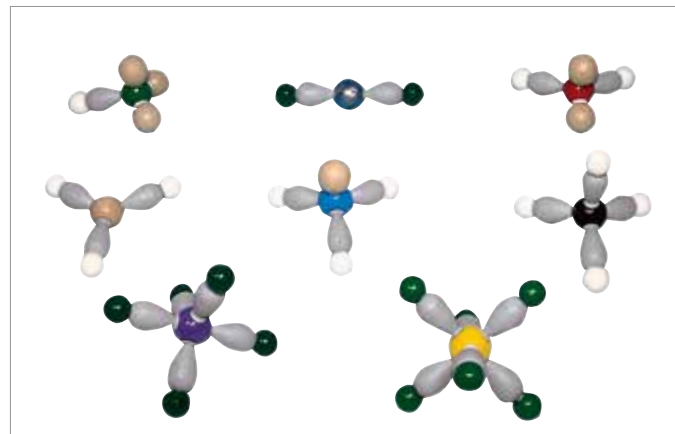

Molyorbital™ 8 Model Collection Set - Electron Repulsion Theory

This 8 model collection set contains sufficient parts to make the eight atomic models shown. The different shapes are examples of the orientations of the bonds and cover coordination numbers 1 to 6. Lone pairs are represented by brown spheres or brown pear shaped parts. The two extra pear shaped parts are included in the set to enable protonated models to be made, e.g. Acid/Base theory, the formation of H₃O as a result of the migration of H⁺ from hydrogen chloride.

1005294 \$30.00

Contents:

- 13 Hydrogen (white)
- 7 Chlorine (green)
- 9 Fluorine (light green)
- 1 Metal (Beryllium) (grey)
- 1 Boron (beige)
- 1 Chlorine (light green)
- 1 Oxygen (red)
- 1 Nitrogen (blue)
- 1 Carbon (black)
- 1 Phosphorus (purple)
- 1 Sulphur (yellow)
- 26 Sigma bonds (grey)
- 6 Lone pair orbital (beige)
- 6 Protonated lone pair orbital (beige)
- 6 Short Link (white)

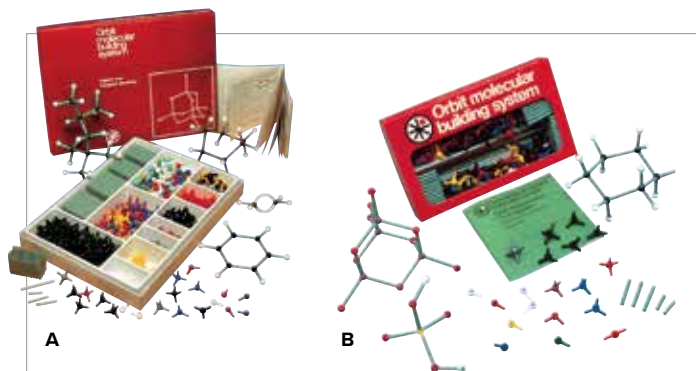

A

B

A. Inorganic/Organic Chemistry Class Set

This set comprises 500 atom centers, scale 3 cm = 100 pm. The atoms consist of plastic centers having prongs set at the correct bond angles. The centers are color coded according to the element, and the bond angles are engraved on the centers and marked by bars. The items consist of: Molecular shape, methane, butane and alkanes, isomerism, carbon compounds with multiple bonds, ring structures, molecules with nitrogen, phosphorous and sulphur, benzene, optical isomerism, sugars, carbohydrates, polymers and complex ions.
20 x 30 x 3 cm; 0.4 kg
1005306 \$85.00

B. Inorganic/Organic Chemistry Student Set

This set comprises 240 atom centers, scale 3 cm = 100 pm. The atoms consist of plastic centers having prongs set at the correct bond angles. The centers are color coded according to the element, and the bond angles are engraved on the centers and marked by bars. The items consist of: Molecular shape, methane, butane and alkanes, isomerism, carbon compounds with multiple bonds, ring structures, molecules with nitrogen, phosphorous and sulphur, benzene, optical isomerism, sugars, carbohydrates, polymers and complex ions.
15 x 20 x 2 cm; 0.2 kg
1005307 \$35.00

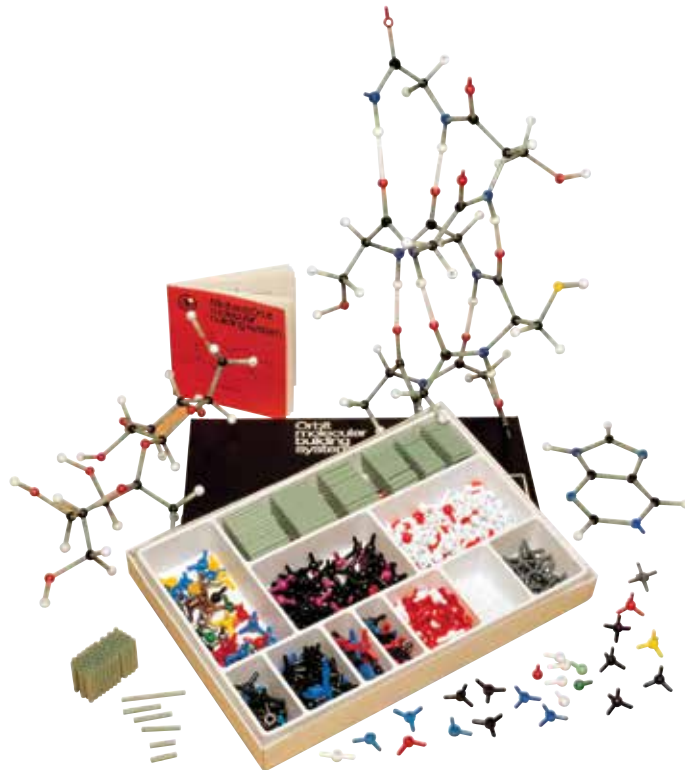

Biochemistry Class Set

This set comprises 390 atom centers, scale 3 cm = 100 pm. The centers are color coded according to the element and the bond angles are marked. Bonds between atoms are made from plastic straws, which can be cut to any required length. The items consist of: Amino acids, monosaccharides, glycerol, fatty acids, steroids, purines and pyrimidines, peptides, disaccharides, lipids, nucleosides, nucleotides, proteins, polysaccharides, nucleic acids.
30 x 20 x 3 cm; 0.3 kg
1005303 \$87.00

Carbon-Carbon Bond

Orbital molecule models representing the sigma and pi bonds found in carbon-carbon pairs: -ethane -ethylene -acetylene -benzene.
51 x 34.5 x 14 cm; 3.0 kg
1002526 \$495.00



Hydrogen Bridge Bond

Hydrogen bonds represent some of the most common and important secondary bonds. *Use this model to illustrate the hydrogen bonding found in:*

- Ice
- Water
- Acetic acid
- HF₂

100 x 26 x 36 cm; 5.0 kg
1002529 \$225.00

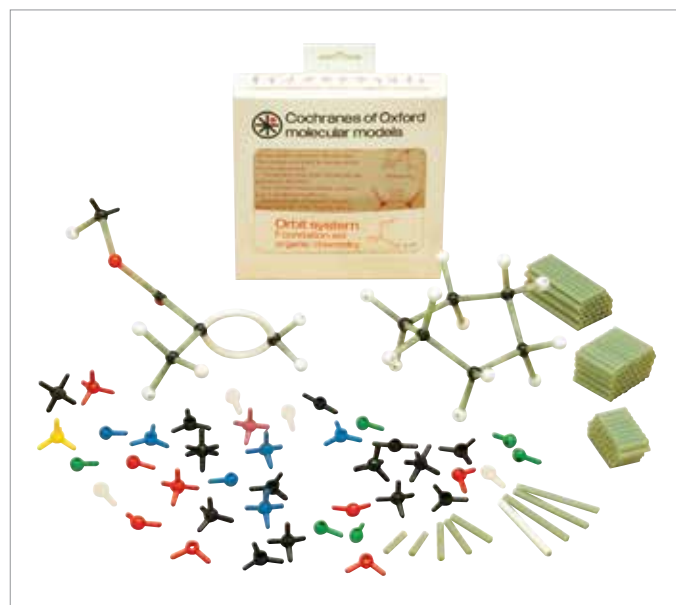
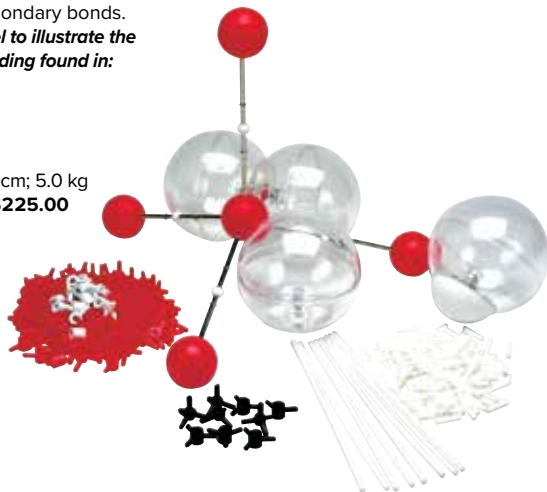

➤ Great for organic & biochemistry

The Orbit Molecular System Foundation Set

This Molecular System is a set of 65 atom centers, scale 3 cm = 100 pm. Capable of building simple organic models, including sugar. The colors of the centers represent the elements. The centers are joined by bonds which fit over the prongs. For simple model building, bonds of 2 or 3 lengths are sufficient.
15 x 15 x 2 cm; 0.1 kg
1005308 \$15.00



Organic Chemistry Teacher Set

Demonstrate the key areas of organic chemistry, including all functional groups, alkanes, alkene, alkynes, alkyhalides, alcohols, ethers, aldehydes, ketones, carboxylic acids, nitriles, amines, esters, aromatic and heterocyclics. Each set comes packed in a plastic box for convenient storage. A wide variety and quantity of atom-parts enables a vast number of possible organic or inorganic models to be assembled and reassembled.

1005278 \$59.00

111 atom-parts:

- 24 Carbon, 4-holes Tetra. black
- 14 Carbon, 6 Tribipy: 2 lin. 6 trig.
- 12 Oxygen, 2-holes Ang. red
- 40 Hydrogen, 1-hole White
- 4 Nitrogen, 4-holes Tetra. blue
- 1 Sulphur, 4-holes Tetra. yellow
- 1 Sulphur, 6-holes Octa. yellow
- 4 Phosphorus, 4-holes Purple
- 8 Halogen, 1-hole Green 17 mm
- 3 Metal, 2 1-hole 17 mm 1 Ang.
- 55 Links grey medium ML-12
- 25 Links grey flexible long ML-13
- 60 Links white short ML-10
- 1 Link remover tool



Biochemistry

A set for making compact models having a very wide range of biochemical structures. The mushroom style atom links are used to give a compact appearance.

Examples of structures include, amino-acids, monosaccharides, fatty acids, glycerol, steroids, purines and pyrimidines, peptides, disaccharides, nucleosides, nucleotides, coenzymes, proteins, polysaccharides, and nucleic acids. Supplied in two large boxes.

1005280 \$111.00

257 atom-parts:

- 42 Carbon, 4-holes Tetra.
- 26 Carbon, 2 Lin. 24 trig. black
- 34 Nitrogen, 12 Tetra 12 trigl. 10
- 40 Oxygen, 20 Ang. 10 lin. 10
- 100 Hydrogen, Atom link white
- 2 Hydrogen, 2-hole Linear white
- 2 Sulphur, 2-holes Ang. yellow
- 6 Phosphorus, 4-holes Purple
- 2 Metal, 1 Tetra. 1 octa. grey
- 150 NV Links colorless
- 100 Linkshort white
- 10 V-links Grey
- 1 Link remover tool

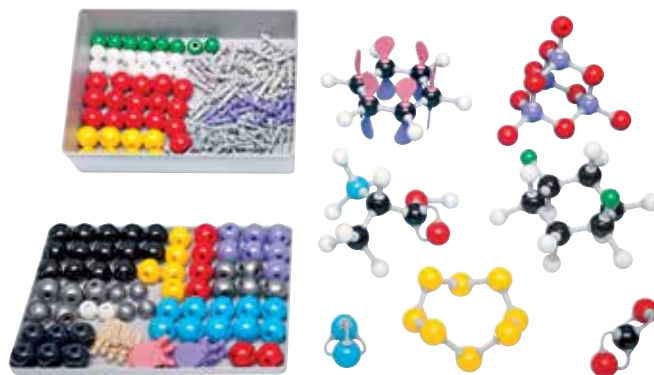

Inorganic/Organic Teacher Set

Each Teacher Set comes with a set of instructions and is packed in a plastic box containing eight trays in two layers for convenient storage of the individual components. A wide variety and quantity of atom-parts enables a vast number of possible organic or inorganic models to be assembled and reassembled.

23.6 x 17.3 x 5.8 cm; 0.82 kg

1005279 \$60.00

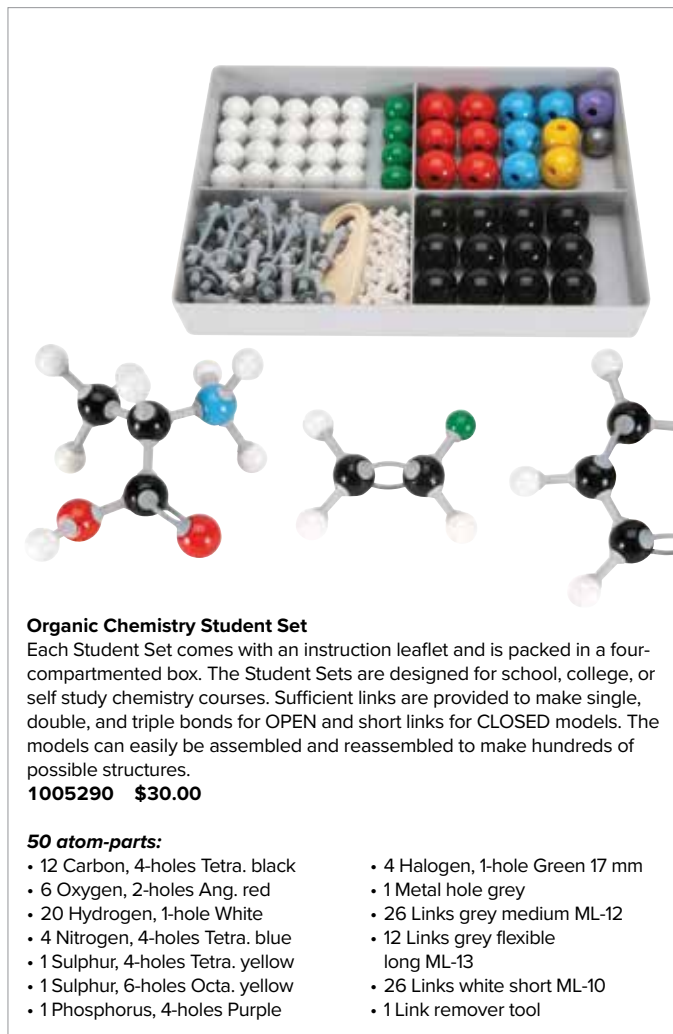

Organic Chemistry Student Set

Each Student Set comes with an instruction leaflet and is packed in a four-compartmented box. The Student Sets are designed for school, college, or self study chemistry courses. Sufficient links are provided to make single, double, and triple bonds for OPEN and short links for CLOSED models. The models can easily be assembled and reassembled to make hundreds of possible structures.

1005290 \$30.00

50 atom-parts:

- 12 Carbon, 4-holes Tetra. black
- 6 Oxygen, 2-holes Ang. red
- 20 Hydrogen, 1-hole White
- 4 Nitrogen, 4-holes Tetra. blue
- 1 Sulphur, 4-holes Tetra. yellow
- 1 Sulphur, 6-holes Octa. yellow
- 1 Phosphorus, 4-holes Purple
- 4 Halogen, 1-hole Green 17 mm
- 1 Metal hole grey
- 26 Links grey medium ML-12
- 12 Links grey flexible long ML-13
- 26 Links white short ML-10
- 1 Link remover tool

**Have a question about our chemistry sets?
Call us at 1.866.448.5846!**

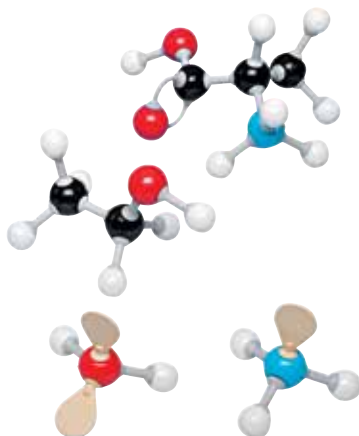

Inorganic/Organic Student Set

Simple inorganic molecules or empirical formulae representations are possible in addition to many organic structures. Examples: Carbon dioxide, ammonia, sulphuric acid, calcium hydroxide, metal salts, copper sulphate, alkanes, alcohols, glucose and benzene. The three brown atoms can be used to represent any element having one sp^3 , one dsp^3 , and one d^2sp^3 in addition to existing element hybridizations. Each set is packed in a four-compartmented box. Designed for school, college or self study chemistry courses. Sufficient links are provided to make single, double, and triple bonds for OPEN and short links for CLOSED models. The models can easily be assembled and reassembled to make hundreds of possible structures.

1005291 \$30.00

These simple yet elegant model sets are the perfect companion for any classroom and a great way to demonstrate chemical compounds in three dimensions.

The Molymod® system is the original, unique, dual-scale system of high quality low-cost molecular models. These enormously popular sets are ideal for students at school and university, and are also used by scientists all over the world.

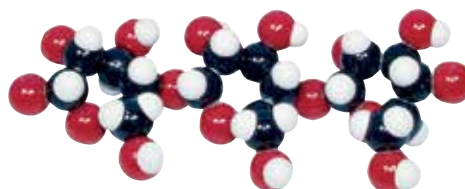

Starch or Cellulose

Self-assembly, three glucose units,
63 Atom-parts, 66 NV links, 1 Tool.

3002540 \$25.00

➤ Ideal for classroom demonstrations or permanent display



Glucose

Self-assembly, two molecules,
48 Atom-parts, 46 NV links, 1 Tool.

1005286 \$19.00



Sucrose

Self-assembly, one molecule,
45 Atom-parts, 46 NV links, 1 Tool.

3002539 \$18.00



Fat (glyceryl tristearate)

Self-assembly, one molecule,
173 Atom-parts, 65 NV links, 1 Tool.

1005287 \$49.00



Polypeptide

Self-assembly, five peptide units, 30 Atom-parts,
12 NV links, 1 Tool.

3002509 \$16.00



Soap

Self-assembly, one molecule, 56 Atom-parts, 24 NV links, 1 Tool.

3002536 \$21.00

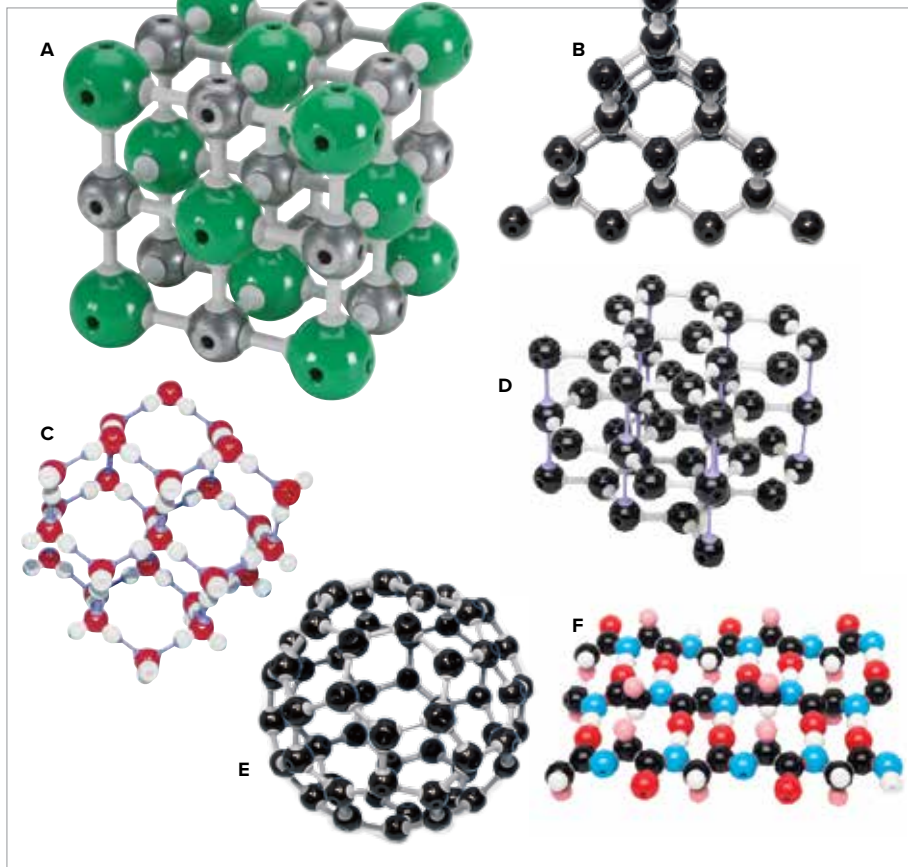

A. Sodium Chloride Molecular Kit

27 Atoms, 13 Metal (grey octa.),
14 Halogen (green octa.), 54 Links (grey medium).
1005281 \$29.00

B. Diamond Molecular Kit

30 Carbon, tetra (black), 40 Links (medium grey).
1005282 \$21.00

C. Graphite Molecular Kit

45 Carbon, tribipyr (black), 51 Links (medium grey),
16 Links long flexible purple.
1005283 \$29.00

D. Ice Molecular Kit

78 Atoms, 26 Oxygen (red), 52 Hydrogen (white),
52 NV links,
45 Medium purple ML-11, 97 Links.
1005285 \$32.00

E. Buckminsterfullerene Kit

60 Carbon, tribipyr (black), 90 Links (medium grey).
1005284 \$33.00

F. Protein-Beta Pleated sheet

Self-assembly, 105 Atom-parts,
60 NV links, 1 Tool.
3002510 \$43.00

➤ Unlock the secrets of the genetic code!

These beautiful models are made of specially shaped, brilliantly colored plastic pieces for easy self-assembly. Display these stunning models on their stand or “unzip” them by removing the central support rod and pulling the helix apart along the hydrogen bonds. Possibly the best models you have ever seen!

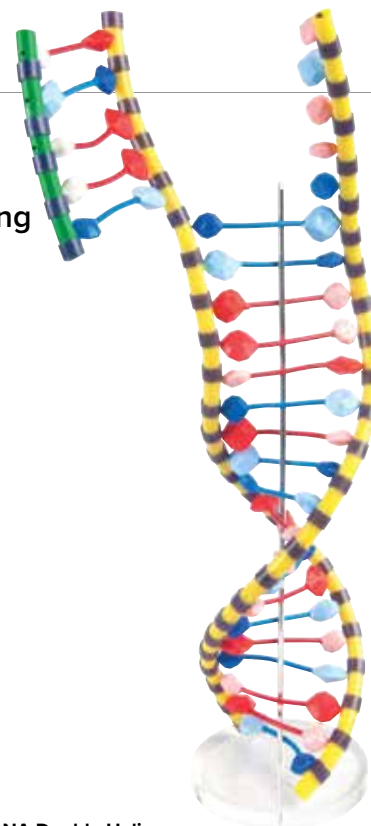

Two Layer Model

A compact model version to make two base pairs, thymine-adenine and cytosine-guanine with ribose-phosphate side chains. Self-assembly. Layers are supported on a small stand and models can be easily dismantled to keep as units in a storage box supplied. 128 atom-parts, 110 links, and 1 tool. On Stand.
3002512 \$64.00



RNA 12 Base Kit

Easily assemble this single strand molecule which consists of the 4 bases, as in DNA, and Uracil. Contains enough material to make all 64 different codons and provides handon investigation into protein synthesis.
3002550 \$21.00

Contents:

- 3 Uracil (light blue)
- 3 Adenine (blue)
- 3 Guanine (green)
- 3 Cytosine (yellow)
- 12 Ribose (red)
- 12 Phosphate (purple)

DNA Double Helix

Three coils of the DNA double helix, consisting of nucleic acids, are represented to demonstrate base pairing. At the top end one RNA cord is attached to show the basis of transcription. On base. 31 x 9 x 9 cm; 0.2 kg
1005128 \$160.00



PHYSICS

At 3B Scientific, we believe hands-on, inquiry-based education lies at the heart of producing new generations of creative, impassioned scientists that are destined to make the world a better place.



- Teacher's manual included
- Kits contain all experiment equipment & digital manuals
- Convenient space-saving container
- Fast experiment setup

Advanced Heat & Thermodynamics Kit

Begin your calorimetry experiments using the universal base plate as a non-tipping experiment platform. The equipment set contains all the components needed for the experiments, apart from consumables no other accessories are needed.

The following experiments may be performed:

- 5 Expansion of bodies by heating experiments
- 4 Heat experiments
- 6 Transmission of heat experiments
- 7 Changing of phase state experiments

1008528 \$302.00

Additionally Required:

Base Plate 1000789 \$96.00



> Required for all SEKs

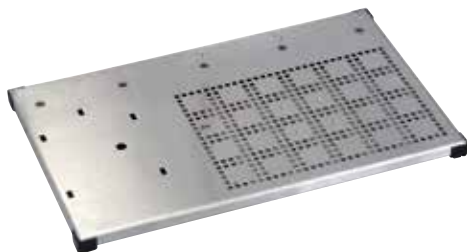

Advanced Kit Base Plate

Tilt-resistant stainlesssteel base with five special threads for stand rods, threads for mounting a dismantlable transformer and expansion slots for the insertion of electrical components. The base has rubber feet for a stable, steady working platform.

400 x 245 x 15 mm
1000789 \$96.00



Advanced Electricity & Magnetism Kit

Nearly two dozen experiments on electricity are ready to be performed with this sturdy, easy-to-use, system. The textured plug-in surface on the universal base plate encourages ordered experiment set-ups.

The following experiments may be performed:

- 5 Electric current experiments
- 3 Electrical voltage experiments
- 10 Electrical resistance experiments
- 2 Electric field in a capacitor experiment
- 5 Magnetic fields experiments
- 3 Electromagnetic induction experiments
- 3 AC circuits experiments
- 3 Transformers experiments

1008532 \$461.00



Advanced Mechanics Kit

Set of equipment for carrying out 23 student experiments in classical mechanics. Comes with comprehensive student and instructor experiment manuals and instructions. In a tough Grattell tray containing a foam insert with cut-outs for the equipment and featuring a transparent lid. Experiments are set up and performed on the Advanced Kit Base Plate (U8408035) so that they are compact but still clear in their layout and objectives.

The following experiments may be performed:

- 10 Force experiments
- 8 Machines for the transformation of forces experiments
- 2 Oscillation experiments

1008527 \$388.00



Advanced Radioactivity Kit

This is a set of apparatus that can be used to carry out 10 basic student experiments on radioactivity. Everything is contained in a durable plastic box with protective form-fitting foam inserts plus a transparent lid. Includes a CD with instructions for the experiments.

Includes 10 experiments on the subject of radioactivity:

- Determining background radiation
- Determining pulse rates for various radioactive preparations
- Statistical distribution of counter pulses
- Determination of equivalent dose for various radioactive preparations
- Penetrative capacity and range of radiation
- Deflection of alpha and beta radiation by a magnetic field*
- Absorption of alpha rays
- Absorption of beta rays
- Absorption of gamma rays
- Inverse square law

1006804 \$241.00



Contents:

- 1 Base plate 340 x 250 mm
- 3 Work templates
- 1 Holder for sources and deflecting magnet
- 1 Deflecting magnet
- 1 Thorium irradiation module I (weld filler wire)
- 1 Uranium glass cube
- 2 Aluminium plates, 0.5 mm
- 1 Aluminium plate, 1 mm
- 1 Lead plate, 2 mm, in plastic cover

Additionally Required:

Base Plate 1000789 \$96.00

Advanced Optics Kit

Individual optical components can be attached by magnets to the universal base plate in a non-slip fashion. Template masks with silhouettes show students the precise positions for the components, ensuring experimental results are reproducible and easily checked. Teachers can copy the masks, modify them and even make masks of their own. Copies of the masks, on which the optical components and the rays observed in the experiments can be drawn, serve as experiment documentation and evaluation for the students.

38 experiments in optics



The following experiments may be performed:

- 4 Light propagation experiments
- 5 Reflection experiments
- 7 Refraction experiments
- 9 Lenses experiments
- 3 The eye experiments
- 5 Optical equipment experiments
- 3 Colors experiments

1008530 \$361.00

Additionally Required:

Base Plate 1000789 \$96.00



- Teacher's manual included
- Kits contain all experiment equipment & digital manuals
- Convenient space-saving container
- Fast experiment setup

Quantity discounts for sets of 8 or more!
Visit 3bscientific.com or call us at 1.866.448.5846

Advanced Electrostatics Kit

This set is used to carry out 15 basic student experiments on electrostatics, and includes parts like an electroscope, charge indicator, charge storage unit and Piezo charger. Everything is contained in a durable plastic box with protective form-fitting foam inserts plus a transparent lid. Includes a CD with instructions for the experiments. The experiments are designed to occupy as little space as possible in the apparatus frame, while remaining clear and easy to perform.

Includes 15 experiments on the subject of electrostatics:

- Electrostatic charging of hair
- Forces on uncharged particles
- Charge indicator
- Forces between charged bodies
- Build your own electroscope
- Electroscope
- Shock of hair
- Demonstrating charge on a capacitor
- Charge pendulum
- Spinner
- Charging due to induction
- Transfer of charge using a charge spoon
- Faraday's cup
- Faraday's cage
- Plate capacitor

1009883 \$442.00



Contents:

- 1 Stand base
- 1 Apparatus frame
- 2 Aluminium rods
- 1 Aluminium rod w/ magnet
- 1 Electroscope
- 1 Plastic plate, angled
- 1 Plastic rod
- 1 Glass rod
- 1 Conductor body
- 1 Set of needles
- 1 Spinner
- 1 Pendulum bob (polystyrene)
- 1 Screw-on needle
- 1 Set of plasticine
- 2 Experiment leads
- 1 Set of papers with 1 plastic cloth
- 1 Set of balloons
- 1 Set of metal strips
- 1 Piezo charger
- 1 Faraday cage

- 1 Faraday cup
- 1 Charge indicator
- 1 Charge storage unit
- 2 Capacitor plates
- 1 Dielectric

Additionally Required:

Basic Student Kit 1000730 \$192.00

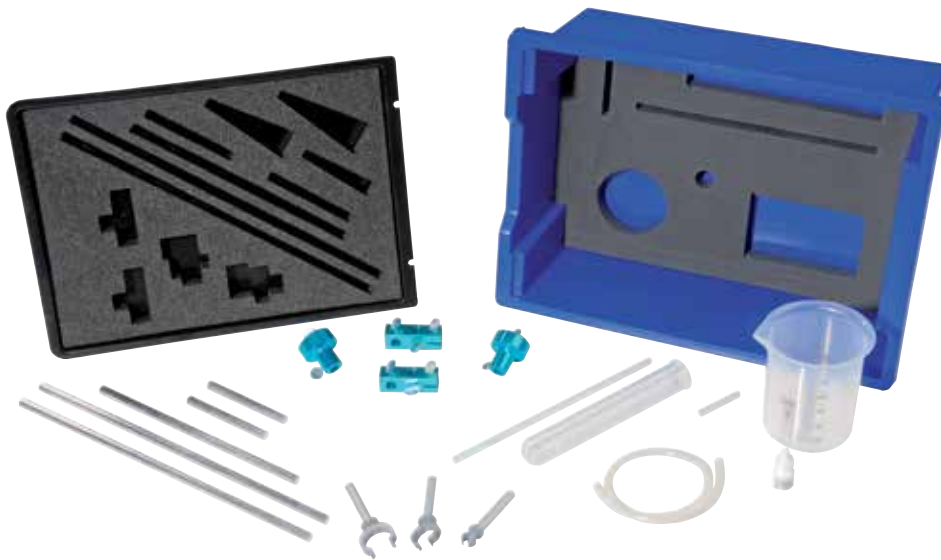

Quantity discounts for sets of 8 or more!
 Visit 3bscientific.com or call us at 1.866.448.5846

Basic Student Kit

Basic set of apparatus for use with student kits for mechanics (U60020) and heat (U60040). Consisting of a robust plastic base-plate, anodized aluminum stands, clamps and various other components used in both mechanics and heat experiments. Everything is contained in a durable plastic box with protective form-fitting foam inserts plus a transparent lid.

1000730 \$192.00

Contents:

- 1 Base plate
- 2 Stand bases
- 2 Stand rods, 360 mm
- 1 Stand rod, 250 mm
- 2 Stand rods, 100 mm
- 2 Double clamps
- 2 Double clamps with slot
- 1 Clip, 8 mm dia.
- 1 Clip 22 mm dia.
- 1 Clip 27 mm dia.
- 1 Beaker, 500 ml
- 1 Test tube
- 1 Glass tube, 50 mm
- 1 Glass tube, 250 mm
- 1 Silicone tube, 500 mm x 6 mm dia.



Basic Optic Kits

Equipment set for carrying out 23 basic student experiments in optics. Everything is contained in a durable plastic box with protective form-fitting foam inserts plus a transparent lid. Includes a CD with experiment instructions.

Optics Experiments:

- Propagation of light
- Light and shadows
- Reflection at a plane mirror
- Concave and convex mirrors
- Refraction of light
- Refractive index
- Optical lenses (paths of rays)
- Focal point of convergent lenses
- Focal length of convergent lenses
- Magnifying glasses
- Function of the eye
- Function of spectacles
- Principle of a camera
- Principle of a slide projector
- Principle of a Galilean telescope
- Principle of an astronomical telescope
- Principle of a microscope
- Breaking down light into its components
- Mixing of colors

1000733 \$319.00

Content:

- 1 Screen
- 1 Optical lamp
- 1 Lens, $f = 50$ mm
- 2 Lenses, $f = 100$ mm
- 1 Lens, $f = 300$ mm
- 1 Lens, $f = -100$ mm
- 2 Slide-holders
- 1 Semi-circular shape
- 1 Lens shape, rectangular
- 1 Lens shape, concave
- 1 Lens shape, convex
- 1 Prism
- 1 Single-slit aperture
- 1 Triple-slit aperture
- 1 Aperture in the shape of an F
- 1 Mirror with magnetic holder
- 2 Small candles
- 1 Opaque object
- 1 Color slide



Basic Mechanic Kit

Set of apparatuses for carrying out 25 basic student experiments on the mechanics of solids, liquids, and gases. Everything is contained in a durable plastic box with protective form-fitting foam inserts plus a transparent lid. Includes a CD with experiment instructions. The experiments are designed to occupy as little space as possible on the base plate of the Student kit set (U60011), while remaining clear and easy to perform.

Mechanics Experiments

- Effects of forces
- Action and reaction
- Deformation by forces (2 experiments)
- Masses and densities of bodies
- Friction (2 experiments)
- Second/third class levers (2 experiments)
- First class lever (2 experiments)
- Fixed pulley
- Moving pulleys
- Combinations of fixed and moving pulleys
- Inclined plane (2 experiments)
- Connected vessels
- Pressure in liquids
- Principle of the U-tube manometer
- Pressure due to weight of fluids
- Buoyancy in liquids
- Floating and sinking
- Air as a body
- Pressure and volume
- Temperature and volume
- Effects of atmospheric pressure

1000731 \$283.00

Contents:

- 1 Steel leaf spring
- 1 Lever arm
- 1 Ruler
- 1 Pulley
- 1 Pulley with hook
- 1 Weight, 100 g
- 3 Weights, 50 g
- 2 Weights, 25 g
- 1 Dynamometer, 2 N
- 1 Metal pivot
- 4 Washer rings to fit metal pivot
- 1 Pulley with cord
- 1 Trolley
- 1 Friction pad
- 1 Coil spring
- 1 Iron block
- 1 Aluminium block
- 1 Wooden block
- 1 Silicone tube,
- 1 Tubing connector
- 1 Clip, 8 mm dia.
- 1 Clip, 14 mm dia.
- 1 Syringe, 50 ml
- 1 Syringe, 30 ml
- 1 Plastic sphere
- 1 Rubber stopper (30 mm x 31/25 mm dia.)
- 1 Funnel, 40 mm dia.
- 1 U-tube manometer
- 1 Measuring cylinder
- 100g Modelling clay
- 500 mm x 3 mm dia.

Additionally Required:

Basic Student Kit 1000730 \$192.00



Student Kit – Heat

Set of apparatus for carrying out 10 basic student experiments on heat. Everything is contained in a durable plastic box with protective form-fitting foam inserts plus a transparent lid. Includes a CD with instructions for the experiments. The experiments are designed to occupy as little space as possible on the base plate of the Student Kit basic set (U60010), while remaining straight-forward and easy to perform.

Heat Experiments:

- Principle of a thermometer
- Heating of solid bodies
- Heating of liquid bodies
- Heating of gases
- Behavior of bimetallic objects
- Conduction of heat
- Radiation of heat
- Condensation
- Distillation
- Temperature of mixtures

1000732 \$116.00

Contents:

- 1 Conical flask, 100 ml
- 1 Bimetallic strip
- 4g Glycerine
- 1 Concave mirror mounted on stem
- 1 Aluminium rod 200 mm
- 1 Thermometer, -10°C – $+100^{\circ}\text{C}$
- 1 Glass tube with 90° bend
- 1 Rubber stopper, 25 mm x 24/19 mm dia.
- 1 Spirit burner
- 1 Ceramic mat

Additionally Required:

Basic Student Kit 1000730 \$192.00

TELTRON® ELECTRON TUBES



Teltron® Luminescence Tube S

Used for investigating luminescence during and after electron bombardment of a phosphorous anode, as well as excitation of fluorescence and phosphorescence. Luminescence can also be observed following irradiation of the phosphorous anode with ultraviolet light.

Cathode filament voltage: $U_f = 7.5 \text{ V}$, $I_f = 1.8 \text{ A}$
 Anode voltage: $U_a = 5 \text{ kV}$
 Anode current: typically $I_a = 150 \mu\text{A}$ at $U_a = 4.0 \text{ kV}$
1000615 \$795.00



Teltron® Perrin Tube S

Used for demonstrating the negative polarity of electron beams through magnetic and electric deflection of the beams towards a laterally positioned Faraday cage connected with an electroscope (i.e. U17250). Also for investigating electron beams in two perpendicularly aligned magnetic alternating fields (operation of a cathode-ray oscilloscope, Lissajous figures) and estimating specific electron charge e/m .

Filament voltage: $U_h \leq 7.5 \text{ V}$ / approx. $I_h \leq 0.35 \text{ A}$
 Anode voltage: $U_a \leq 5 \text{ kV}$
 Anode current: typically $I_a = 150 \mu\text{A}$ at $U_a = 4 \text{ kV}$
 Beam current: typically $I_a = 0.4 \mu\text{A}$ at $U_{aa} = 4 \text{ kV}$
 Deflection voltages: $U \leq 350 \text{ V}$
1000616 \$882.00



Teltron® Maltese Cross Tube S

Used for demonstrating the linear propagation of electron beams in field-free spaces by projecting the shadow of a Maltese cross on a fluorescent screen. Also intended for observing the focusing of electron beams by magnetic fields as an introduction to electron optics. Comparison between the Maltese cross shadows of electron beams and electromagnetic radiation (light) in a magnetic field.

Cathode filament voltage: $U_f = 7.5 \text{ V}$, $I_f = 1.8 \text{ A}$
 Anode voltage: $U_a = 5 \text{ kV}$
 Anode current: typically $I_a = 150 \mu\text{A}$ at $U_a = 4.0 \text{ kV}$
1000011 \$773.00

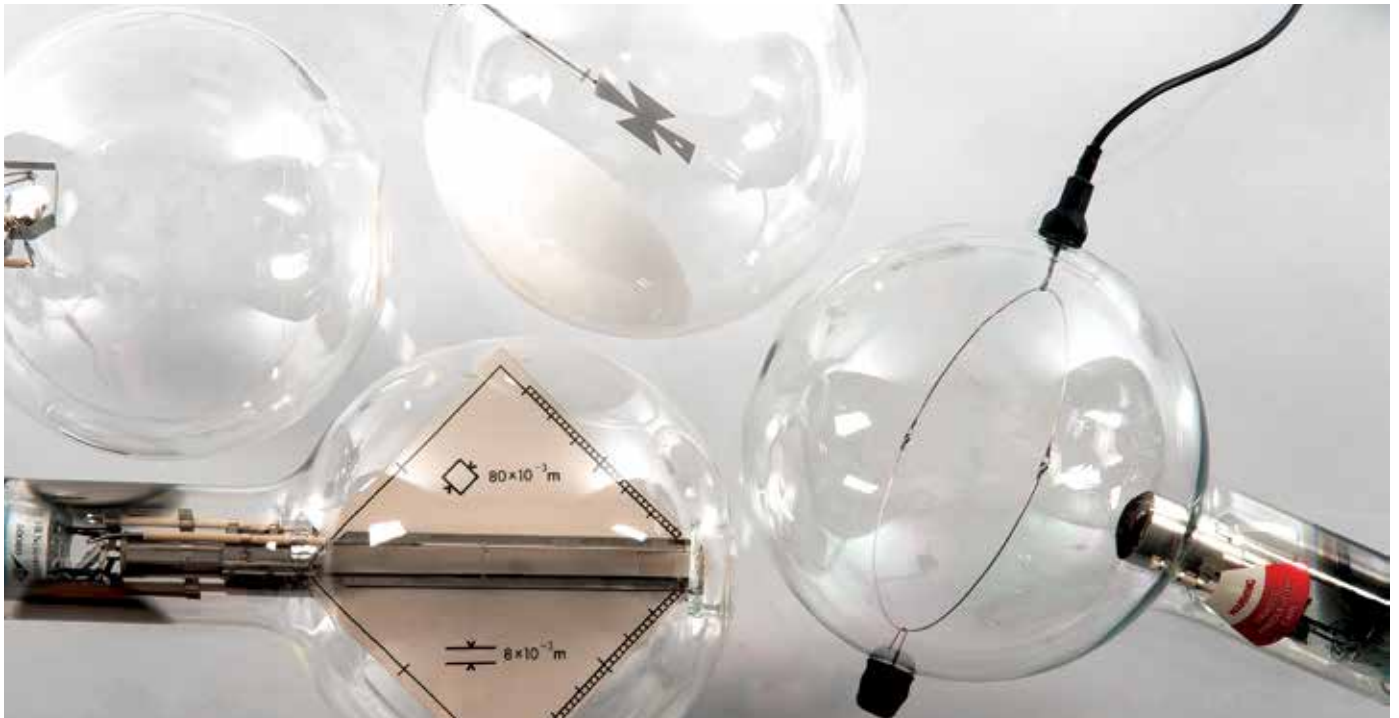

A. Teltron® Diode S

Used for investigating the Edison effect (thermionic effect) representing emission currents as a function of the heating power of the hot cathode. Recording the characteristics of diodes and demonstrating their application as rectifiers is possible. Also intended for determining specific charge e/m by means of the magnetron method (Helmholtz coils, U185091).

Cathode heating voltage: $U_h \leq 7.5 \text{ V}$, $I_h \leq \text{approx. } 3 \text{ A}$
 Anode voltage: $U_a \leq 300 \text{ V}$
 Anode current: typically $I_a = 6.0 \text{ mA}$ at $U_h = 7.5 \text{ V}$, $U_a = 300 \text{ V}$

1000613 \$552.00

B. Teltron® Triode S

Used for quantitative investigations of controllable high-vacuum tubes. Recording triode characteristics, determining the negative polarity of electron charges and generating cathode rays (model of an "electron gun") is possible. Also intended for investigating technical applications of triodes as amplifiers and oscillators (with Helmholtz coils, U185091).

Cathode heating voltage: $U_h \leq 7.5 \text{ V}$ / $I_h \leq 3 \text{ A}$
 Anode voltage: $U_a \leq 300 \text{ V}$
 Anode current: typically $I_a = 1.4 \text{ mA}$ at $U_h = 7.5 \text{ V}$, $U_a = 300 \text{ V}$
 Grid voltage: $-300 \text{ V} \leq U_g \leq 300 \text{ V}$
 Grid current: typically $I_g = 0.9 \text{ mA}$ at $U_h = 7.5 \text{ V}$, $U_a = 300 \text{ V}$

1000614 \$631.00





Teltron® Thomson Tube S
 Used for investigating electron beams in electric and magnetic fields and determining specific charge e/m through compensation of magnetic deflection by electrostatic deflection or ascertaining the radius of curvature of the electrons in the magnetic field. Also used for estimating the speed of electrons.
 Cathode filament voltage: $U_f = 7.5 \text{ V}$, $I_f = 0.4 \text{ A}$
 Anode voltage: $U_a = 5 \text{ kV}$
 Anode current: typically $I_a = 0.2 \text{ mA}$ at $U_a = 4 \text{ kV}$
 Deflection voltage: $U = 350 \text{ V}$
1000617 \$1,102.00



Teltron® Electron Diffraction Tube S
 Highly evacuated electron tube for determining the wavelength of electrons as a function of the anode voltage from the radii of the diffraction rings and the distance between the lattice planes of graphite (Debye-Scherrer-diffraction) and rendered visible on a fluorescent screen. Also intended for determining the wavelengths of monochromatic radiation at different anode voltages from the radii of the diffraction rings and the lattice plane spacing of graphite, as well as confirming de Broglie's hypothesis.
 Filament voltage: $U_f \leq 7 \text{ V}$, $I_f \leq 0.4 \text{ A}$
 Anode voltage: $U_a \leq 5 \text{ kV}$
 Anodenstrom: approx. $I_a = 0,1 \text{ mA}$ at $U_a = 4.0 \text{ kV}$
 Lattice constant of graphite: $d_{10} = 0.213 \text{ nm}$, $d_{11} = 0.123 \text{ nm}$
1013889 \$1,323.00



Teltron® Gas Triode S
 For quantitative investigations of the typical properties of a gaffled triode. Allows user to record the $I_a - U_a$ characteristics of a thyratron, as well as observe independent and dependent discharge and discontinuous energy release comprising He and Ne atoms during inelastic collisions with free electrons.
 Filament voltage: $U_h \leq 7.5 \text{ V}$ / approx. $I_h = 3 \text{ A}$
 Anode Voltage: $U_a \leq 300 \text{ V}$ (He)
 Grid Voltage: $-300 \text{ V} \leq U_g \leq 300 \text{ V}$ (He)
 $100 \text{ V} \leq U_g \leq 100 \text{ V}$ (Ne)
1000618 \$728.00

A. Helmholtz Coils S

For generating magnetic fields for electron beam deflections in the tube holder (U185001).

Number of coil turns: 320 each
 Coil diameter: 138 mm

Load rating:

Continuous operation: 3000 A/m (12 V DC, 1.0 A)
 Short-term operation: 4500 A/m (18 V DC, 1.5 A)
 DC resistance: $R = \text{approx. } 6 \Omega$
 Connection: via 4 mm jacks

1000611 \$616.00

B. Tube Holder S

The tube holder serves as a mounting for the entire Teltron tube line (U18552–U18571), for the student experiments and related accessories such as Helmholtz coils (U185051) and auxiliary coil (U19100).

The tube holder with its five pole socket allows easy access to almost all tube connections via 4 mm jacks. In addition, a cathode protection circuit is integrated in the tube holder to safeguard the hot cathode against overvoltage.

1014525 \$609.00





Fine Beam Tube Power Supply

- Beam voltage / accelerating voltage: 15 – 400 VDC adjustable with front panel control
 - Coil current: 0 – 4.5 A adjustable with front panel control
 - Fine tuning of the filament voltage from 4 to 7 V
 - Fine tuning of the focusing cup voltage from 0 to -50 VDC
 - Meters: two 3-digit LED panel meters for the Beam voltage and the Coil current
 - Low voltage measuring outputs (4 mm plugs) for Beam voltage and Coil current
 - Rotatable Tube over an angle of 270°
 - Coil diameter: 30 cm
 - Magnetic Field: max. 3.4 mT @ 4.5 A or 0.75 mT / A
 - Dimensions: 310 x 275 x 410 mm³
 - Weight: 71 kg (without tube)
- 1013843 \$2,160.00**

Additionally Required:

e/m Fine Beam Tube 1008505 \$936.00



Teltron® Auxiliary Coil D

Used for generating two perpendicularly aligned magnetic fields in conjunction with the demonstration Helmholtz coils (U185091) for the purpose of deflecting electron beams in a Perrin tube.

1000645 \$275.00



Control Unit for Critical Potential Tubes

Control unit for operating the critical potential tubes; equipped with an output for sawtooth acceleration voltages; adjustable upper and lower limits of the acceleration voltage; integrated pico-ammeter amplifier for anode-current measurement. Allows recording of the acceleration voltage as a function of the anode current.

1000633 \$648.00

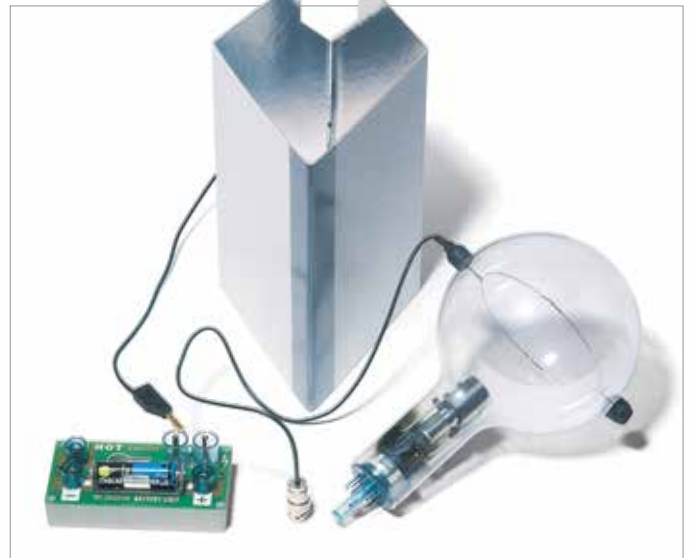

Teltron® Critical Potential Tube S

Used for quantitative investigations of inelastic collisions of electrons with inert gas atoms, determination of ionization energy and excitation energies of helium or neon, resolution of the energy states of various primary and orbital angular-momentum quantum numbers, as well as demonstrating meta-stable states. Includes shielding as well as a discharge tube and battery unit (battery included in the scope of delivery) for the collector voltage. (He) TEL 2533.02 (Ne) TEL 2533.10. See 3bscientific.com for additional items required.

Cathode filament voltage: $U_f = 3\text{ V}$, $I_f = 1.3\text{ A}$
 Anode voltage: $U_a = 60\text{ V}$
 Anode current: $I_a = 10\text{ mA}$
 Collector voltage: $U_c = 1.5\text{ V}$
 Collector current: $I_c = 200\text{ pA}$

Helium Filled 1000620 \$1,138.00
Neon Filled 1000621 \$1,138.00



Teltron® Dual Beam Tube S

Used for Helium-filled tube with a tangential and axial electron gun. The electron paths are rendered visible in the form of fine luminescent beams through impact excitation of the helium atoms. For determining the charge to mass ratio from the diameter of the electron beam in the case of tangential bombardment and a perpendicularly aligned magnetic field, and observing spiral paths of electrons in the case of axial bombardment and a co-axial magnetic field. **See 3bscientific.com for additional items required.**

Cathode filament voltage: $U_f = 7\text{ V}$, $I_f = 0.35\text{ A}$
 Anode voltage: $U_a = 300\text{ V}$
 Anode current: $I_a = 30\text{ mA}$
 Deflection voltage: $U = 60\text{ V}$

1000622 \$1,098.00



Advantages:

- Track cannot bend (on stable support with U-shaped profile)
- Length of track 1.9 m
- Sliders move with almost zero friction

Air Track

Track with square profile and 2 gliders for investigating frictionless linear motion. Mounted on a robust U-shaped base resting on three feet that can be adjusted to ensure horizontal alignment. The air is blown in from the front and escapes through small air outlets arranged in 2 rows along the track. This allows for practically frictionless movement of the gliders on the triangular track with no tilting. With millimetre tape measure.

| | |
|-----------------|--------------------|
| Material: | Anodized aluminium |
| Total length: | 2.00 m |
| Working length: | 1.90 m |

| | |
|--|-------------------------------|
| Maximum deviation from straight line over complete length: | 0.02 mm |
| Track profile: | Square, 63x63 mm ² |
| Thickness of walls: | 3 mm |
| Separation of air outlets holes: | 20 mm |
| Base profile: | U-shaped profile |
| Width of base: | 40 mm |
| Height of base: | 40 mm |
| Wall thickness of base: | 4 mm |

1019299 \$1,419.78

Contents:

- 1 Air track on U-shaped base profile resting on three feet
- 2 Gliders made of black anodised aluminium with 4-mm holes to accommodate velocity flags and other accessories, plus pins at the sides to hold additional weights, mass: 180 g, length: 125 mm
- 4 Additional 50 g weights
- 1 Velocity flag with plug for interrupting light barriers, mass: 10 g, width: 100 mm
- 2 Velocity flags with plug for interrupting light barriers, mass: 5 g, width: 25 mm
- 3 Forks with plugs and rubber bands for catapulting gliders and investigating elastic collisions, mass: 10 g
- 3 Plates with plugs for investigating elastic collisions, mass: 10 g
- 1 Needle with plug for investigating inelastic collisions, mass: 10 g
- 1 Small tube with plug and plastic filling for investigating inelastic collisions, mass: 10 g
- 1 Hook with plug for attaching a thread with accelerating weights on the end, mass: 10 g
- 1 Pulley for frictionless deflection of accelerated masses
- 1 Set of screws and tools for assembling air track
- 1 Manual

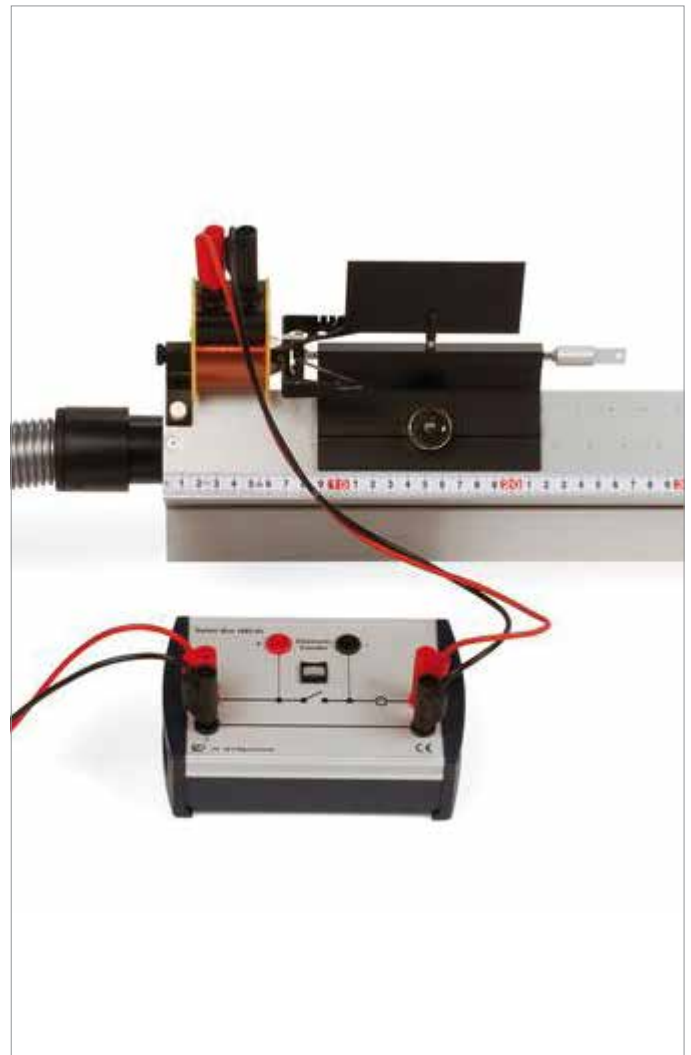

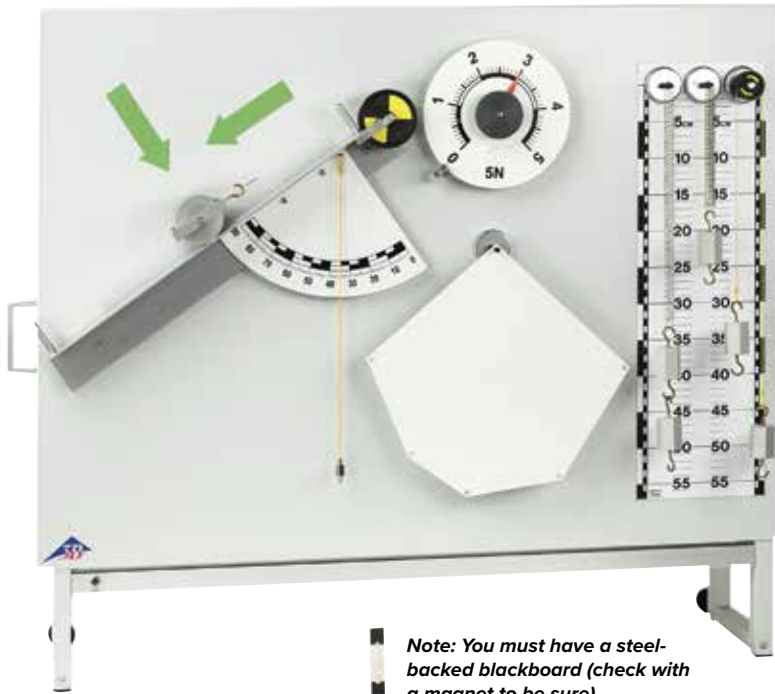

Note: You must have a steel-backed blackboard (check with a magnet to be sure).



Experiment Topics:

- Inclined plane
- Levers – 1st, 2nd and 3rd class
- Physical equilibrium (torques and forces)
- Forces on a crane
- Fisherman's scale
- Force vectors – addition
- Force vectors – components
- Pendulum motion
- Physical pendulum
- Pulley systems and mechanical advantage
- Hooke's Law
- Mass on a spring
- Coupled resonance
- Center of mass
- Static and sliding friction

Whiteboard Mechanics

The Whiteboard Mechanics system consists of large, colorful, and easy-to-see components, made of heavy-gauge aluminum and stored in a foam-cushioned wooden storage case. Setting up a demonstration is quick and simple!

All measuring parts mount on the whiteboard surface by means of high quality magnets and are large enough to be seen clearly from the back of a classroom or lecture hall. In minutes students or instructors can set up over 30 different experiments. The dramatic demonstrations promote a clear understanding of basic concepts of mechanics. Hang the masses, attach the scales, and let your students see the results for themselves.

Units of measure, vector diagrams and explanations can be written on the board right next to your demonstration set-up. Seeing the principles of mechanics operate while you explain them adds tremendous visual impact and makes lectures more memorable and understandable.

1000735 \$1,093.00

System includes:

- Inclined plane
- Rolling mass, 500 g
- Multipurpose beam, 54.5 cm
- Index rod, 40 cm long
- Counterweight, 20 g
- Double pulley block, 70 mm, 40mm
- Two pulleys – 70 mm and 40 mm
- Two round scale dynamometers, 5N
- Three anchor posts
- Three springs, $k=6.2\text{ N/m}$
- Linear scale, 55 cm long
- Four arrows and fulcrum
- Six masses – double-hooked, 100 g each
- Friction block
- Stringnylon
- Center of gravity plate
- Plumb bob
- Fitted storage case
- Instruction manual

Additionally Required:

- Whiteboard 600 x 900 mm 1002591 \$123.00**
- Whiteboard 900 x 1200 mm 1002592 \$182.00**

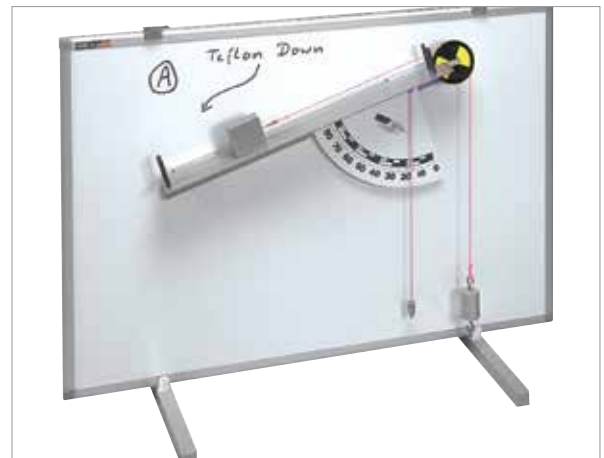
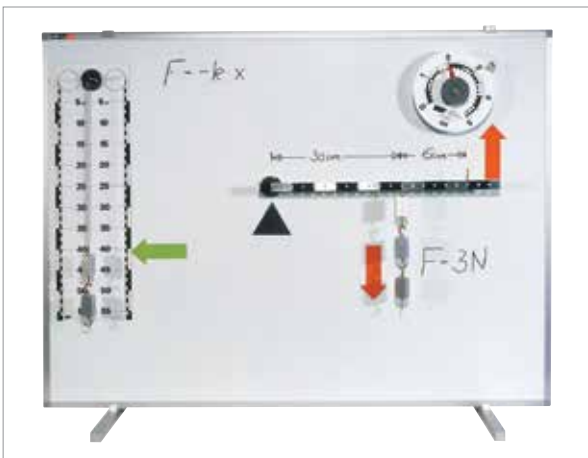

Record your demos with an HD camera!

A. Projectile Launcher

Experimental equipment for the quantitative investigation of projectile laws: vertical, horizontal and angled launch, recording of flight trajectories depending on launch angle and projectile range.

Includes:

- 1 Projectile Launcher
- 3 Spherical plastic projectiles
- 1 Ramrod
- 1 Wing nut M8x20

1002654 \$560.00

B. Clamp Mount

Table clamp for Projectile Launcher U10360.
Made of anodized aluminum.

1002655 \$158.00

C. Ballistic Pendulum

This apparatus is used for experiments on elastic and inelastic collisions and for performing projectile experiments using the projectile launcher. The lightweight anodized aluminum construction of the pendulum eliminates the need to use steel balls as projectiles. The equipment is attached to a bench via a clamp.

Includes:

- 1 Ballistic pendulum with table clamp
- 2 Extra weights

1002656 \$764.00

Additionally Required:

Projectile Launcher 1002654 \$560.00

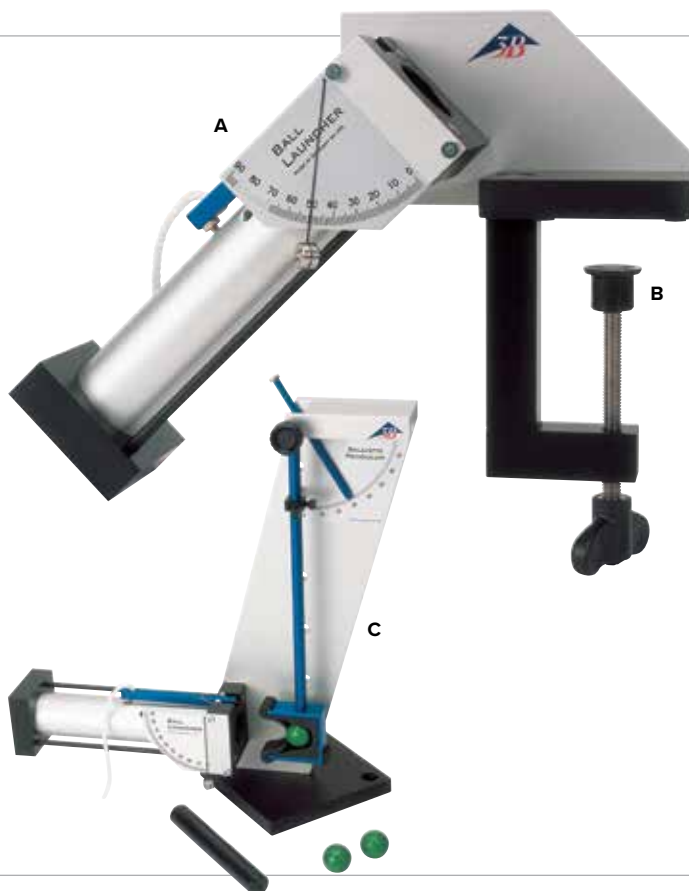

Stability Apparatus

Demonstrates the stability of an object in relation to its center of gravity. The supporting beams can be tilted so that the hanging weight will shift the object's center of gravity into differing locations.

1002950 \$90.00



Center of Gravity Plate

For introducing the concept of center of gravity and determining centroids. The plastic plate has six boreholes and washable labeling.

1008513 \$25.00



Springs Set for Hooke's Law

A set of 5 springs, each with pointer attached to provide a variety of spring constants. Use with hooked weights.

1003376 \$15.00



Student Force Table

This student force table is a complete set with these new features:

- Dual scale that allows students to take readings either clockwise or counterclockwise
- 3 Complete weight sets with (2x) 5g, 10g, 20g, 50g brass slotted weights and a 50 g hanger
- 3 pulleys with clamps and two sets of strings that allow students to investigate the equilibrium of either three or four forces
- A lightweight durable table top and a sturdy cast iron support that allows both ease of use and accuracy

1000694 \$467.00



Pulleys, Block and Tackle Experiment Set

Demonstrates how forces can be altered in direction and modified in magnitude by simple machines (fixed and movable pulleys, block and tackle). Also introduces the concepts of mechanical work, power and energy. Comes in a complete set consisting of a stable base plate, retort stand rods, pulley blocks, block and tackle, a set of pulleys of various diameters on an axle, weight holders, slotted weights and a reel of cord. Experiments are simple and easy to set up. The enclosed design of the pulley blocks' plastic frames ensures that the cord cannot slip off the pulley.

Base plate: 810 x 200 mm
 Stand rods: 810 x 12.5 mm Ø
 Slotted weights: 2 x 10 g, 2 x 20 g, 2 x 50 g, 4 x 100 g,
 4 x 200 g, 1 x 500 g
 Holders: 1 x 10 g, 1 x 20 g, 5 x 50 g

1003224 \$633.00

Additionally Required:

Measuring Tape **1002603 \$23.00**
 Dynamometer **1003106 \$27.00**



Economy Lever

Used to study mechanical leverage and balance. A movable fulcrum can slide along and be fastened on any point of a 50 cm stick. Various weights can then be applied to balance the system and to study leverage systems. Consists of a 50 cm stick, stand, three knife edge clamps, one 50 gram hooked weight and one 100 gram hooked weight. Instructions included.

3001293 \$36.00

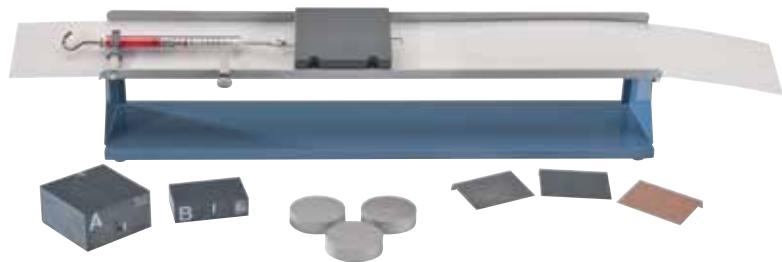

Apparatus for Measuring Friction

This demonstration apparatus is used to measure static and dynamic friction between various surfaces. The plane of friction – a coated, U-profile aluminum friction track – is hinged at one end to a steel base plate. A protractor scale is used to measure the angle of inclination.

1009942 \$550.00



Economy Spark Timer

Determine the rate of acceleration in a falling weight, calculate the speed of a moving cart or study the forces of friction. A paper strip is pulled through the device while sparks burn tiny dots on the paper at very precise time intervals. The faster the strip passes through the device the sparks the larger distance between dots. It is easy for the student to calculate the velocity and acceleration. Additionally everything on the spark timer is enclosed for safety. Instructions included.

3001298 \$31.00

Replacement Parts

Paper Roll **3001299 \$1.00**
 Carbon Disk **3001300 \$1.75**



Wooden Blocks for Friction Experiments

Each with a plastic coated surface. Complete with hooks for fastening a spring scale.

12 x 6 x 6 cm; 12 x 3 x 3 cm

1002944 \$34.00



Thermal Conductivity Equipment Kit

Kit for the qualitative investigation of the heat conductivity of aluminum (extremely high thermal conductivity) and expanded polystyrene (very low thermal conductivity). Even at room temperature the varying material temperatures are evident to the touch.

1003497 \$21.00

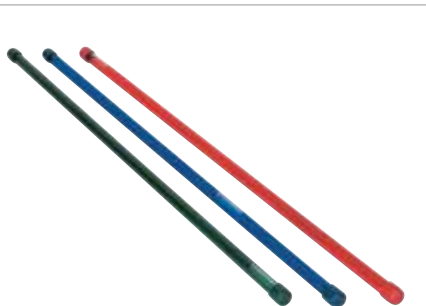

Constant Velocity Student Kit

Set of equipment for investigating the concept of velocity by means of student experiments. Consisting of three small colored plastic tubes in which an air bubble rises at constant velocity in a viscous liquid, provided the tubes are aligned vertically. Since the viscosities differ, the velocities also differ. The position of the air bubble is plotted against time. The three different resulting straight lines lead to a definition of velocity.

1003502 \$39.00

A. Free Fall Apparatus

Apparatus for measuring the time it takes for a ball to fall a certain distance using a digital timer. Very easy to set up and use but nevertheless highly accurate. Includes 3 steel balls. A micro-magnet holds the ball in its start position. Three contact pins under the release mechanism ensure that the start position of the ball can be reproduced and act as the contacts of a switch that opens when the ball is released, thus triggering the beginning of the timing measurement. When the ball strikes the contact plate at the bottom, the timer is stopped. The ball is also held firmly on the plate so that it does not bounce. The height through which the ball drops can be adjusted to a fraction of a millimetre and read off a scale on the column.

- Height scale: 20 – 960 mm
 - Scale divisions: 10 mm
 - Scale precision: 0.2 mm
 - Balls: Steel, 16 mm dia.
 - Dimensions: approx. 200 x 130 x 1000 mm
- 1000738 \$459.00**

Additionally Required:

- B. Millisecond Counter 1012833 \$170.00**
- C. Digital Counter 1001032 \$600.00**

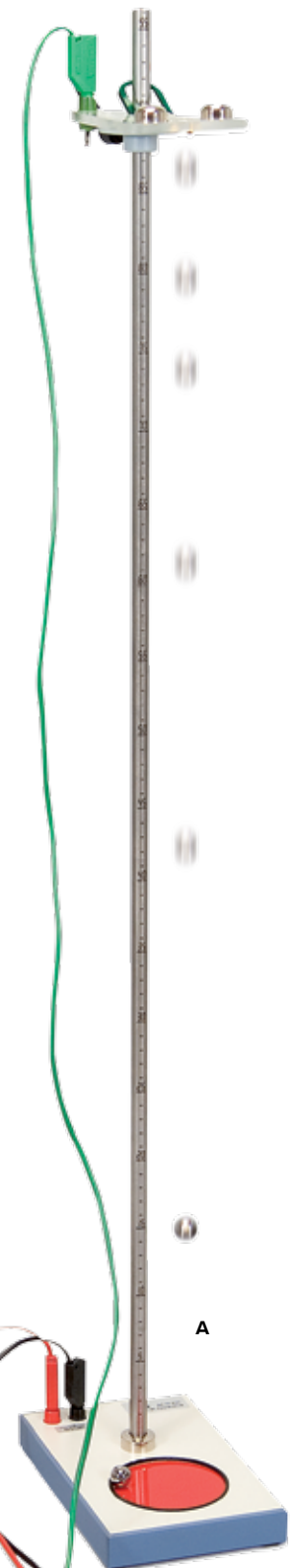
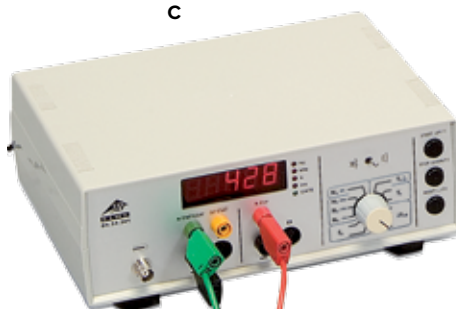
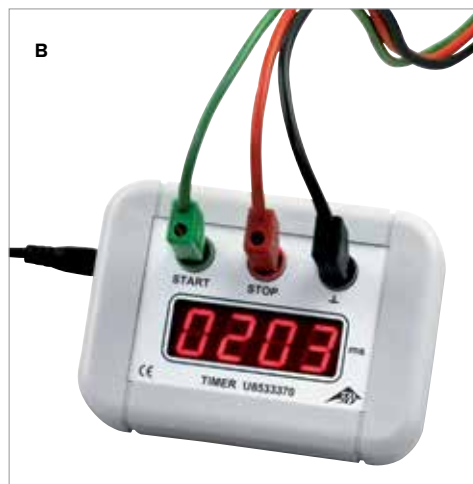

*Have questions about our products?
Contact us at 1.866.448.5846 or
visit 3bscientific.com*

Dual Launcher S

Experimental apparatus for studying vertical and horizontal trajectories as well as trajectories starting at intermediate angles. Also demonstrates the independence of the horizontal and vertical components of motion (for projectiles). Including stand rod and bench clamp.

Provides for three different launch velocities. Angle of launch can be adjusted to any arbitrary angle and read off from a protractor scale with a plumb line.

The projectile ball is held in place by a magnet until the moment of launch so that the height of the trajectory is independent of the launch angle. When a projectile is launched, a second ball can be released simultaneously from the other side of the launcher that then descends in free fall. The latter should strike the floor at the same time as the projectile if the launch angle is horizontal.

Launch angle: $0^\circ - 90^\circ$

Maximum range: 3 m

Projectile diameter: 16 mm

Projectile weight: 22 g

1000740 \$317.00

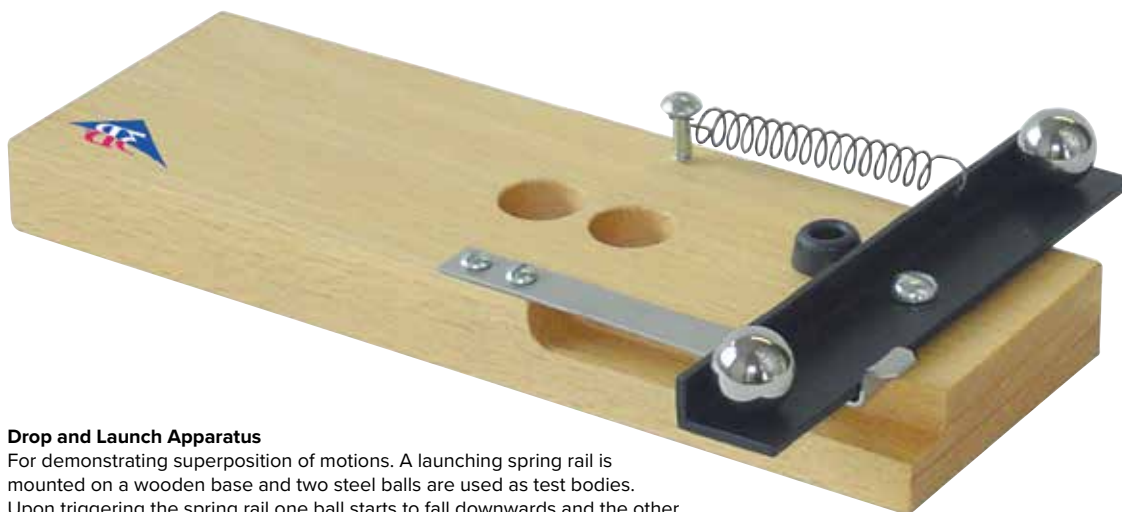

Drop and Launch Apparatus

For demonstrating superposition of motions. A launching spring rail is mounted on a wooden base and two steel balls are used as test bodies. Upon triggering the spring rail one ball starts to fall downwards and the other is simultaneously launched horizontally. Both balls hit the ground at the same time. Two holes in the base plate are provided for storing the balls.

Ball diameter: 15 mm

1000588 \$89.00



Deluxe Maxwell's Wheel

For demonstrating conversion of kinetic energy into potential energy and vice versa. By placing the equipment set directly onto scales, it can be used to measure inertial forces during acceleration. Two panels at the ends of the axles prevent the wheel from coming off. A photocell light barrier can be used to measure speed of translation. Includes retaining rod and adjustable mount.

Moment of inertia: approx. 10 kg cm^2

Diameter of wheel: approx. 130 mm

Mass of wheel: approx. 470 g

Retaining rod: $370 \times 12 \text{ mm } \varnothing$

1000790 \$195.00

Additionally Required:

Duplex Stand Base 1002836 \$66.00

2 Steel Rods 1002932 \$9.00

2 Universal Clamps 1002830 \$30.00

Gyroscope Kit

Gyroscope for qualitative and quantitative determination of gyroscopic laws by means of practical experiments. The experiment apparatus is a shaft that can tilt vertically and rotate horizontally while attached to a rod stand. On one side of the shaft there is a disc mounted on dual ball bearings, while on the opposite side there is a movable counterweight for establishing equilibrium. Fine adjustment is performed by thumb screw at the end of the shaft. To generate external torque an additional weight is provided that can also be moved along the shaft. The shaft's angle of inclination can be read from an easily readable scale. A spirit level allows the gyroscope to be adjusted to the horizontal. The disc can be set rotating by hand or by means of a cord. The dual ball bearing system ensures that rotation is nearly frictionless and continues for lengthy periods of time. The open construction of the gyroscope allows gyroscopic phenomena to be observed easily and clearly.

Scale: - 40° to 40°
 Scale divisions: 1°
 Disc: 250 mm Ø
 Mass of disc: 1500 g
 Mass of counterweight: 50 g, 1400 g

Experiment topics:

- Moment of inertia of a disc
- Torque
- Angular momentum
- Precession
- Nutation

1000695 \$804.00

Gyroscope Accessory Kit

Accessory kit for Gyroscope U52006 consisting of a gyroscope disc and counterweight. For demonstrating the canceling out of gyroscopic phenomena in the case of two discs rotating at the same speed in opposite directions.

1000698 \$241.00

Additionally Required:

| | | |
|-----------------------------------|----------------|-----------------|
| Duplex Stand Base | 1002836 | \$66.00 |
| Stainless Steel Rod, 47 cm | 1002934 | \$15.00 |
| Bosshead | 1002827 | \$12.00 |
| Mechanical Stopwatch | 1002810 | \$114.00 |



Duplex stand base



Bosshead

Laser Tachometer

This tachometer is an excellent tool for mechanics experiments or demonstrations as it allows non-contact RPM measurements of rotating objects. Simply apply reflecting tape on the object to be measured and point the laser for quick and easy measurements.

Features:

- Make non-contact RPM measurements of rotating objects
- Memory button holds last reading and recalls min/max readings
- Easy to read large 5 digit LCD display.
- Rugged double molded housing for better grip
- Includes 9V battery

3004161 \$159.99



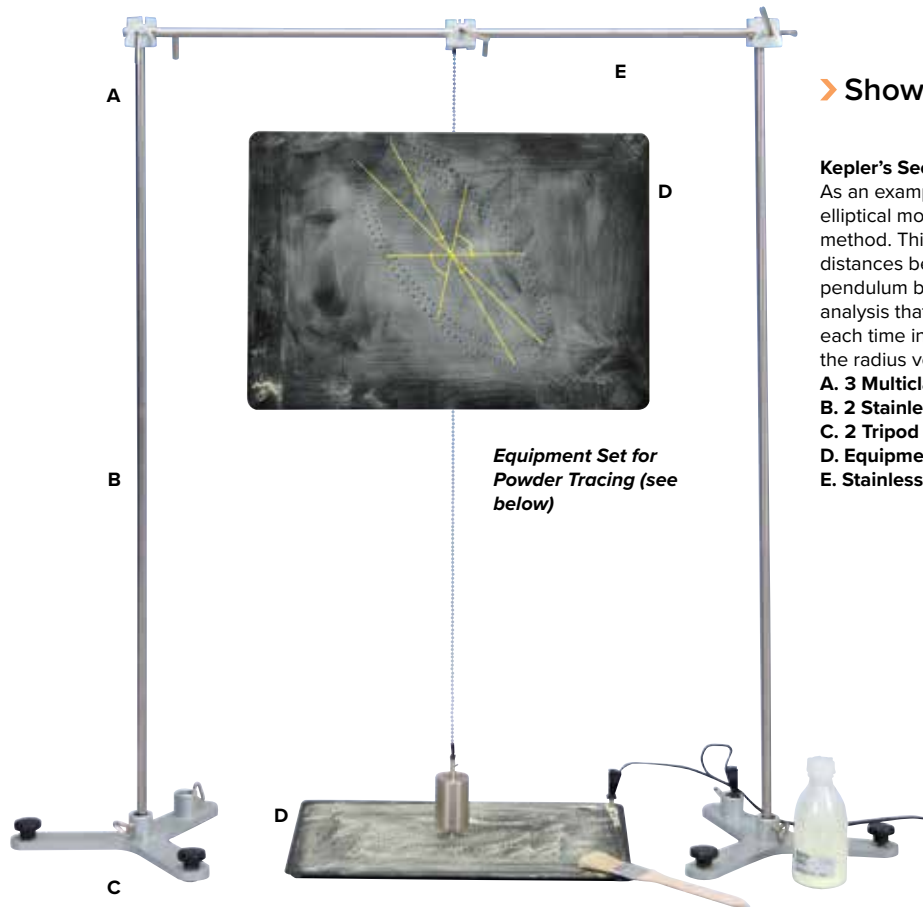

Equipment Set for Powder Tracing (see below)

➤ Show how the planets behave!

Kepler's Second Law Experiment

As an example of motion under the influence of a central force, the elliptical motion of a pendulum bob is recorded by the dust-marking method. This produces a trace with time-interval marks, and from the distances between these one can directly measure the velocity of the pendulum bob. Furthermore, it can be shown by a simple graphical analysis that the area swept by the radius vector of the pendulum in each time interval is constant, and is thus independent of the length of the radius vector.

| | | |
|--|----------------|-----------------|
| A. 3 Multiclamps | 1002830 | \$30.00 |
| B. 2 Stainless Steel Rods 100 cm | 1002936 | \$13.00 |
| C. 2 Tripod Stands 150 mm | 1002835 | \$62.00 |
| D. Equipment Set for Powder Tracing | 1000739 | \$188.00 |
| E. Stainless Steel Rod 75 cm | 1002935 | \$21.00 |



F. Experiment Motor with Gearbox

Experiment motor for universal use in experiments on rotational motion, e.g. for experiments using the rings demonstrating flattening of the earth (U8403120). Can also be used as a generator in conjunction with the included hand crank. Robust clockwise and counter-clockwise rotating IDC motor with epicyclic gearbox and quick-action chuck in a tough anodized aluminum casing with removable and adjustable stainless steel stand rod. Can also be mounted on the clamp for the projectile launcher (U10361). Speed of rotation is adjusted by altering the supply voltage. Adjustable torque. Includes 3 belt pulleys of different diameters on a mounting axle.

| | |
|---------------------|------------------------------------|
| Speed without load: | approx. 480 rpm at 12 V |
| Speed sensitivity: | approx. 40 rpm per V |
| Span of chuck: | 0.8 – 10 mm |
| Stand rod: | 12 mm dia. |
| Pulleys: | 10 mm dia., 20 mm dia., 40 mm dia. |
| Axle: | 10 mm dia. |
| Drive belt: | 130 mm dia. x 4 mm |
| Nominal voltage: | 12 V DC, 5A |
| Connection: | Via 4-mm safety sockets |

1002663 \$636.00

G. Watt's Governor

Demonstrate the principle of controlling rotational speed (e.g. steam engines). A dual pendulum is placed centrally on an axle. As it rotates, the metal cylinder on the axle experiences a force opposed to the force of gravity; this regulates the speed of rotation. A spring causes the pendulum to be restored to its initial position.

| | |
|--------------------|--------|
| Rotation diameter: | 300 mm |
| Height: | 230 mm |
| Diameter of axle: | 10 mm |

1009695 \$102.00

➤ Period of oscillation as a function of the inclination!



Deluxe Rotation Apparatus

For determining the angular acceleration as a function of torque and for determining the moment of inertia as a function of the distance of the body from the axis and its mass. A vertical, rotating axle with agate bearing supports a crossbar for holding the weights. The force of the driving weight is transferred via a pulley and a cord wrapped around a pulley wheel on the axis.

Dimensions of the base plate: 200 x 140 mm
 Length of crossbar: 600 mm
 Pulley wheel diameter: 9/18 mm
 Total weight: approx. 1.3 kg



Includes:

- Weights, 100 g, Set of 2
- Weight, 200 g
- Pulley
- Cord

1006785 \$501.00

Variable Gravity Pendulum

For determining the period of oscillation as a function of the pendulum length and of the acceleration due to gravity. Pendulum consisting of a virtually massless rod with sliding weight and clamp for attaching to a tripod with an infinitely variable plane of oscillation.

Max. length of pendulum: 280 mm
 Mass of pendulum: 0.5 kg
 Angle of plane of oscillation: 0° to 90°
 Dimensions: 300 x 250 x 550 mm
 Mass: approx. 5 kg

1000755 \$337.00

Additionally Required:

| | | |
|----------------------------|----------------|-----------------|
| Duplex Tripod Base | 1002835 | \$62.00 |
| Digital Counter | 1001032 | \$600.00 |
| Stainless Steel Rod | 1002934 | \$15.00 |





Deluxe Foucault Pendulum

For the quantitative measurement and qualitative demonstration of the earth's rotation. Oscillation of the pendulum is maintained by means of electromagnetic excitation. The position of the plane of oscillation can be read off to a high degree of accuracy via an optical measuring device with laser. Quantitative values for the angular velocity can be achieved within short experimental times.

Length of pendulum: 120 cm
 Mass of pendulum: 230 g
 Diameter: 38 mm
 Damping of elliptical motion: Charron ring
 Control: Via photosensor
 Mechanism for exerting excitation force: Electromagnet
 Excitation force: Infinitely variable
 Housing: Metal housing, fully glazed with front door, 4 leveling feet

Measurement of plane of oscillation: Shadow projection of pendulum cable

Angular resolution: 0.1°
 Dimensions: 400 x 400 x 1400 mm
 Mass: approx. 40 kg

1000747 \$6,702.00

Pendulum Rod with Angle Sensor

Pendulum system with low-friction cone bearings and electromagnetic angle sensor. For investigating harmonic oscillations, damping due to air resistance, coupled oscillations and Lissajous figures. The angle of the pendulum is converted into a proportional electrical signal by a Hall sensor. This signal can be used to record the oscillation using an interface, an XY plotter or an oscilloscope. The pendulum bob is movable.

Length of pendulum: 1 m
 Mass of pendulum: 1 kg
 Output voltage: ± 5 V
 Output resistance: 500 Ω
 Precision: $\pm 1\%$ for $d = 14^\circ$ (sin $d = 0.24$)
 Power supply: 12 to 16 V AC
 Diameter of tube: 10 mm

1000762 \$570.00

Pendulum Rod without Angle Sensor

1000764 \$206.00

Additionally Required:

| | | |
|----------------------|---------|------------|
| Duplex Stand Base | 1002835 | \$62.00 |
| AC/DC Power Supply | 1002775 | \$292.00 |
| Stainless Steel Rod | 1002934 | \$15.00 |
| Analog Oscilloscope | 3001445 | \$738.00 |
| Digital Oscilloscope | 3001448 | \$2,502.00 |

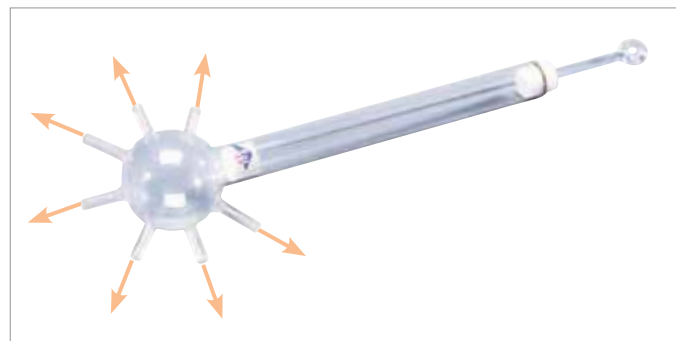

Pascal's Pressure Sphere

Excellent for viewing and class demonstrations. A piston distributes the pressure so that water is sprayed equally far in all directions.

1002892 \$187.00



Sphere for Weighing Gases 1000 ml

Glass sphere with two taps and nozzles for attaching tubing for demonstrating the weight of air from the difference in weight between the sphere when filled with air and when evacuated.

1003519 \$85.00

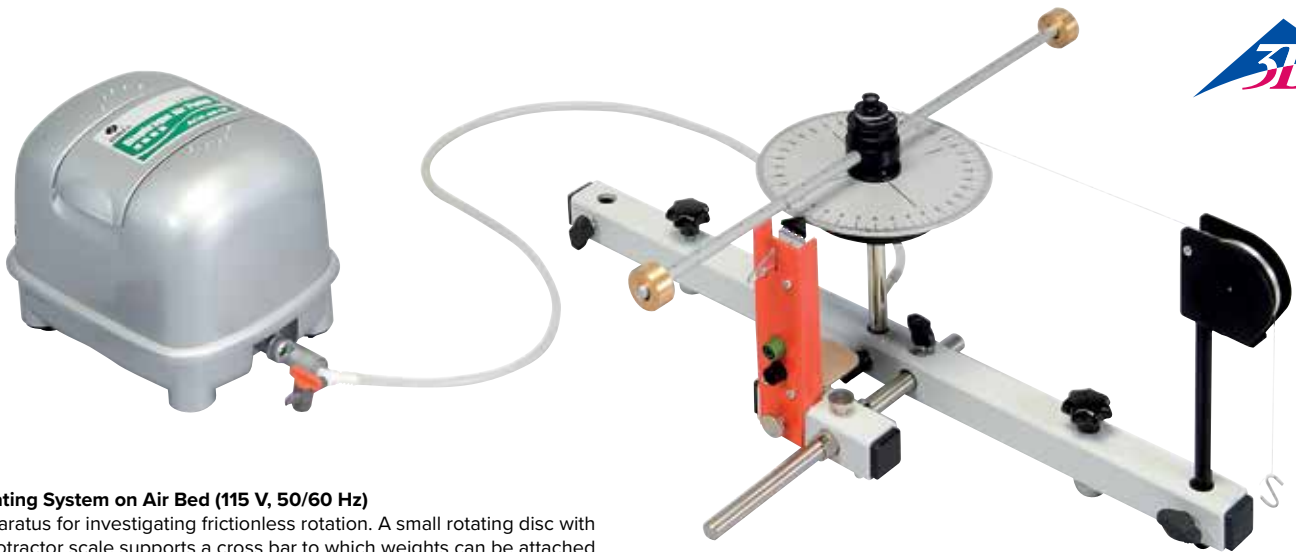

Rotating System on Air Bed (115 V, 50/60 Hz)

Apparatus for investigating frictionless rotation. A small rotating disc with a protractor scale supports a cross bar to which weights can be attached. The disc is supported by a bed of air in which its axis is centered. A driving weight is suspended from a hook at the end of a string that is passed over a single pulley on one side and a multiple pulley on the other. The rotation is very slow and can be measured using a stopwatch by hand. Alternatively, a digital timer may be used. This can be started by a mechanism that is supplied with the kit and halted by a signal from a laser reflection sensor when the wheel passes through angle zero.

1000781 \$1,236.25

Additionally Required:

Laser Reflection Sensor 1001034 \$561.00
Digital Counter 1001032 \$600.00

| | |
|---|------------------------------|
| Protractor scale: | 0 – 360° |
| Scale divisions: | 1° |
| Length of cross bar: | ca. 440 mm |
| Radii of perforations: | 30 – 210 mm |
| Separation of perforations: | 20 mm |
| Radii of multiple pulley: | 5.0 mm/10.0 mm/15.0 mm |
| Moment of inertia of disc with cross bar: | approx. 0.16 gm ² |
| Maximum moment of inertia: | approx. 7.1 gm ² |
| Minimum driving torque: | approx. 0.05 mN m |
| Maximum driving torque: | approx. 0.60 mN m |



Density Set, 12 materials

Twelve sets of test bodies made of the same material but with four different weights for deriving the concept of density in school experiments. Supplied in storage containers. Wood, polypropylene, polyamide, acrylic (2 colors), polyurethane, phenol, PVC (3 colors), Teflon and aluminum.

1003500 \$118.00

Density Set, 2 materials (not shown)

Two sets of test bodies made of the same material but with four different weights for deriving the concept of density in school experiments. Supplied in storage containers.

1003499 \$20.00



Set of 15 Bodies with 2 Different Densities

Set of 15 test bodies of various masses made of two identical looking materials for deriving the concept of density in experiments at school.

1003501 \$49.00

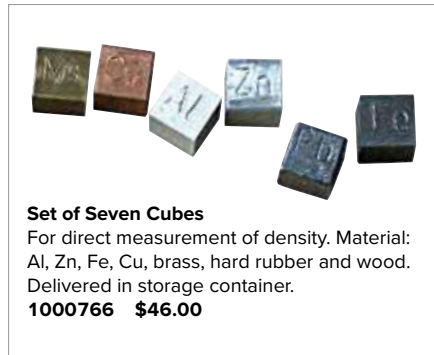

Set of Seven Cubes

For direct measurement of density. Material: Al, Zn, Fe, Cu, brass, hard rubber and wood.

Delivered in storage container.
1000766 \$46.00

Cartesian Diver

Demonstrates a body floating, sinking or rising in water. The body is a hollow figure made of colored glass, with a narrow opening. The figure floats upright in a cylinder filled with water and can be made to float, sink or rise by applying pressure to the rubber cap. The rubber cap fits cylinder diameters of approx. 30 mm to 40 mm.

Includes:

- 1 Cartesian diver
- 1 Rubber cap

1002867 \$31.00

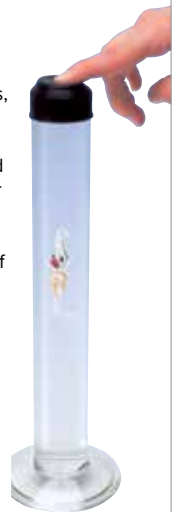

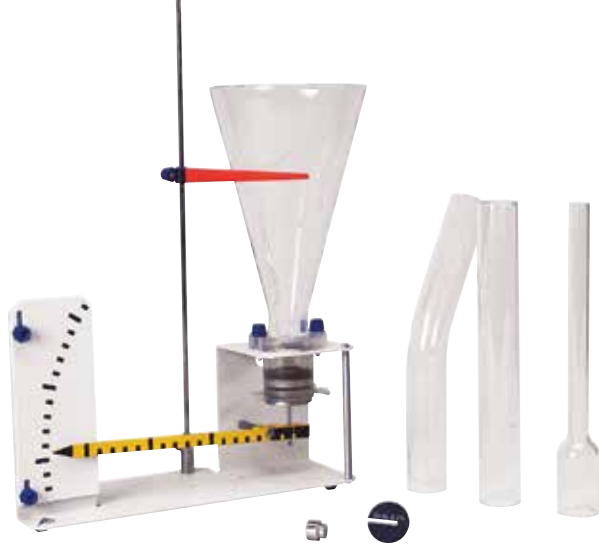

Pascal's Vane Apparatus

For demonstration of the hydrostatic paradox and quantitative measurements on ground pressure. This pressure is measured through the curvature of a membrane and indicated in magnified form with the help of a level multiplier. Allows compensation for comparative measurements. Includes four differently shaped vessels.

Tube diameter at the bottom: 2.6 cm
 Height of the vessels: 25 cm
 Total height: 35 cm
 Dimensions of base: 28 cm x 11 cm

1002957 \$256.00

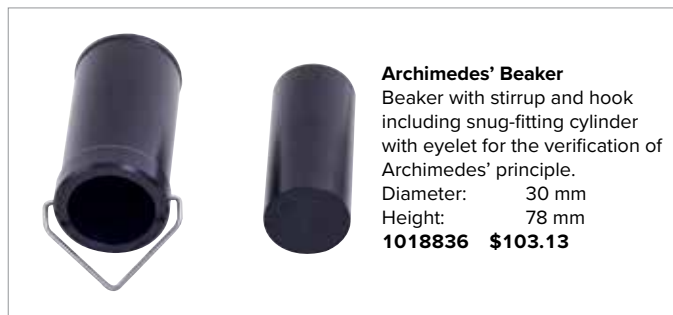

Archimedes' Beaker

Beaker with stirrup and hook including snug-fitting cylinder with eyelet for the verification of Archimedes' principle.

Diameter: 30 mm
 Height: 78 mm

1018836 \$103.13

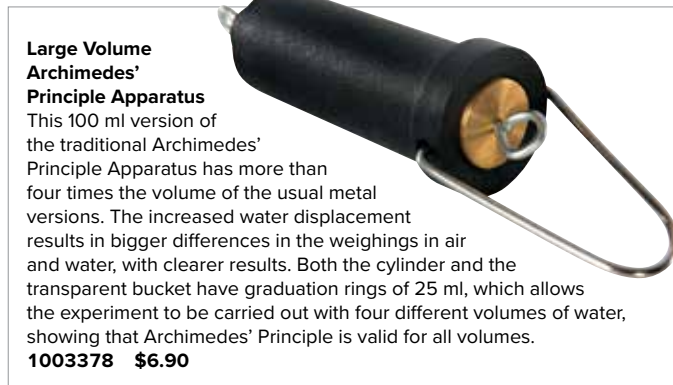

Large Volume Archimedes' Principle Apparatus

This 100 ml version of the traditional Archimedes' Principle Apparatus has more than four times the volume of the usual metal versions. The increased water displacement results in bigger differences in the weighings in air and water, with clearer results. Both the cylinder and the transparent bucket have graduation rings of 25 ml, which allows the experiment to be carried out with four different volumes of water, showing that Archimedes' Principle is valid for all volumes.

1003378 \$6.90



Pressure Apparatus with 2 Pistons

For introducing the concept of pressure and for studying transmission of pressure in liquids and gases as well as the functioning of a hydraulic press.

Includes:

- 2 graduated glass cylinders,
- 10 ml and 50 ml, with plungers
- Transparent hose
- T-piece and connecting sleeves
- Additional weights 2 x 50 g, 1 x 100 g, 2 x 200 g
- Aluminum rail with two boreholes for accommodating the glass cylinders

1002653 \$345.00



Glass Cylinder with 2 Tubes

Glass vessel for demonstrating communicating tubes. Consists of a glass cylinder with two openings and GL screw connections, as well as two differently shaped glass tubes.

1002891 \$72.00



Capillary Tubes Apparatus

Four capillary tubes each with a different internal diameter are connected to a glass reservoir with filling tube. Water rises to a different level in each of the tubes demonstrating the relationship between the bore of the tube and capillary pressure.

Capillaries: 2.0 mm, 1.5 mm, 1.0 mm and 0.5 mm inner diameter

Height: approx. 165 mm

1003510 \$51.00



Piston Vacuum Pump

For performing simple vacuum experiments – for instance, evacuation of the (e.g. vacuum bell jar U21851). Solid construction which enables you to generate a low vacuum without much effort. Piston with grips, heavy base bracket, connection for suction hoses with diameters of $d = 5 - 15$ mm.

Final pressure: 0.3 bars
 Dimensions: 160 x 235 x 560 mm Weight: approx. 1.7 kg
1000798 \$104.00

Additionally Required:

Vacuum Hose 1002619 \$28.00



Vacuum & Pressure Hand Pump

Simple mechanical air pump for filling and evacuating small containers; equipped with an ergonomic handle, a manometer with a pointer that rotates through a full 360°, a ventilation valve, two hoses (long and short) and six connecting adapters.

Final pressure: From -980 hPa to 4000 hPa
 Tubing nozzle: 8.5 mm diam.
 Hose: 850 mm x 6.5 mm internal diam.
 65 mm x 4.5 mm internal diameter
 Dimensions: approx. 180 x 60 x 260 mm
 Weight: approx. 0.3 kg
1012856 \$177.00

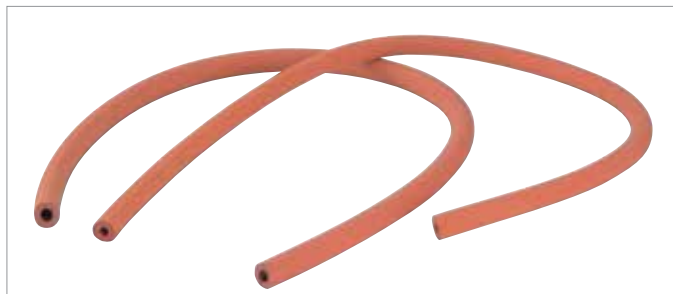

Vacuum Hoses

Our Vacuum hoses are made of natural rubber according to DIN 12865. Color red.

| Item Number | Price | Length | Internal Dia. | Wall Thickness | Temp Range |
|-------------|---------|--------|---------------|----------------|-------------|
| 1002619 | \$28.00 | 1 m | 8 mm | 5 mm | -30C to 85C |
| 1002620 | \$34.00 | 1 m | 10 mm | 5 mm | -30C to 85C |



Rotary-Vane Vacuum Pump, 100 L/min

High performance, compact, two-stage, oil-sealed rotary vane pump for vacuum experiments. With thermal overload protection, handle, air valve, manometer and hose nipple. Includes pump oil.

Suction capacity: 100 L/min
 Final pressure: 0.01 hPa
 Motor power: 245 W
 Manometer: 0 – 1000 hPa
 Hose nipple: 10 mm dia.
1003317 \$488.00

| | | | | |
|--|--|---|---|---|
| | | | | |
| <p>Crosspiece DN 16 KF Connection: DN 16 K Dimensions: 80 x 44 mm 1002924 \$92.00</p> | <p>2-Way Ball Valve DN 16 KF Connection: DN 16 KF Length: 100 mm 1002923 \$257.00</p> | <p>Tension Ring DN 10/16 KF Tension ring for mechanically secure connection of ISO-KF components. 1002930 \$22.00</p> | <p>Ventilation Valve DN 16 KF Connection: DN 16 KF Dimensions: 36 x 26 mm Ø 1002926 \$230.00</p> | <p>Adapter Flange DN 16 KF / NS 19/26 Connection: DN 16 KF Core: 19/26 NS Length: 40 mm 1002929 \$78.00</p> |

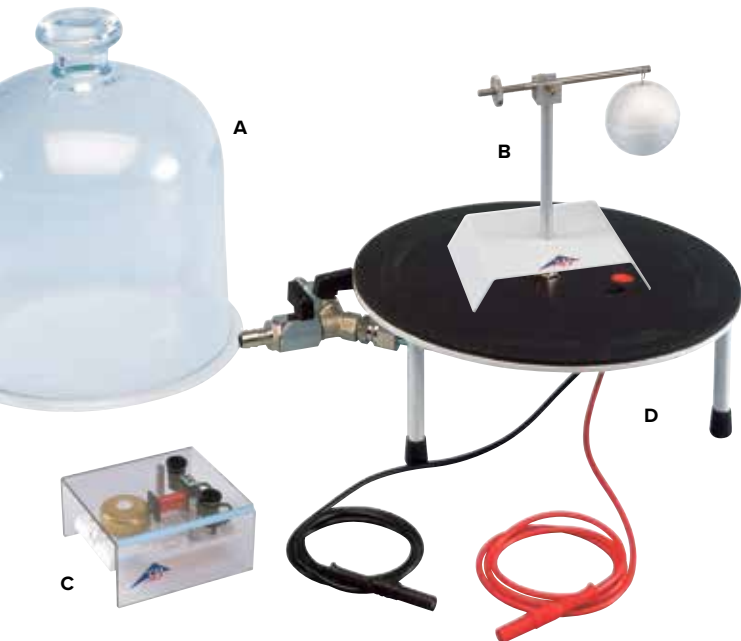

C. Electric Doorbell

Used for demonstrating electromagnetic operation of machinery and verifying that sound waves do not propagate in a vacuum (< 1 mbar). Open acrylic housing with 4-mm safety sockets.

Power supply: 6 V AC
 Dimensions: 100 x 95 x 50 mm
1003170 \$108.00

Experiment Topics:

- Bell in a Vacuum
- Boil water at room temperature
- Experiment with marshmallows, balloons and shaving cream
- Determining the mass of evacuated air and its density
- Effect of air pressure on a partially inflated balloon and a miniature bellows

A. Vacuum Bell Jar

Our Vacuum Bell Jar is made of glass with a secure grip knob and polished flange. Set this jar on top of the vacuum experiment plate (U21850) to create a vacuum chamber in your classroom.

Inner diameter: 190 mm
 Total height: 220 mm

1019299 \$136.00

B. Baroscope

Perform an undeniable demonstration illustrating the concept that the loss of weight of an object in air equals the weight of the air displaced by it. When the air in the bell jar is then evacuated the styrofoam sphere falls because of the reduction in lift.

Sphere: 50 mm \varnothing
 Base: 120 x 90 mm
 Height: 125 mm

1003169 \$113.00

D. Vacuum Experiment Plate

Assemble your own vacuum chamber, in conjunction with the Vacuum Bell Jar (U21851), to perform experiments in the coarse and fine vacuum range. The experiment plate is metal with sealing ring on a tripod. Includes hose connection on the pump-side, ventilation cock and vacuum-tight current feed with 4-mm safety sockets. Center bore with M12 thread for attaching experiment equipment.

Diameter: 250 mm
 Height: 90 mm
 Current feed-through: 2-pole with 4-mm safety sockets (red, black) via 2 cables (red, black) approx. 1 m long with 4-mm safety plugs
 Power feed: max. 48 V, max. 12 A

Electrical limit specs: max. 48 V, max. 12 A
 Vacuum connection: hose nozzle \varnothing 12 mm and 10 mm

1003166 \$260.00



Free Fall Tube

Used for proving that gravitational acceleration and the duration of fall in a vacuum is equal for all bodies, when air resistance and buoyancy are absent. Consists of a glass cylinder with two stoppers. One stopper has a stopcock and can be connected to a suction hose.

Falling bodies: Corks, feather, metal disc.
 Connection nozzles: 10 mm
 Dimensions: 800 x 36 mm (LxD)
 Weight: approx. 650 g

1000801 \$117.00

Pythagorean Cup

Pythagoras is known to most students today as the author of the Pythagorean Theorem ($a^2 + b^2 = c^2$). There was far more to Pythagoras' philosophy than this: he was a deep thinker on religion, the nature of the soul, and the harmony of the cosmos. With the "Pythagorean Cup" he illustrated to his students the virtues of moderation: when filled halfway, it retains its contents, but if it's too full, all of the liquid drains out through a hole in the bottom.

Our Pythagorean cup is made of hand-blown clear glass. The secret of the construction is a siphon, which is built in the center of the cup. Ideal for explaining to your students the principle of a siphon with an historical background.

Height: 25 cm
 Cup: 8 cm diameter

1002904 \$127.00



**Have questions about our products? Contact us at
 1.866.448.5846 or visit 3bscientific.com!**



Jet Nozzle (Flow Laminator)

For generating an almost homogenous air flow for flow experiments in connection with an air flow generator (e.g. fan U15425-115). The jet nozzle spreads the air blowing from the fan. The air mixes with the secondary air to form a total air current of a large diameter. Nozzle has no moving components, it does not produce any eddies and is very light and is suited for conducting almost all experiments connected with air currents.

Dimensions: 255 x 150 mm (LxD)

Air inlet: 33 mm

Air outlet: 120 mm

Stand holder: 10 mm

Weight: approx. 350 g

1000758 \$175.00

Additionally Required:

Variable Air Supply **1000605 \$552.50**

Component Balance

Consists of a clamping fixture for measuring air resistance and buoyancy on a wing or on resisting bodies U8404260. The component balance can be applied for measuring forces in any arbitrary direction.

Measuring range: 0 – 0.3 N

Diameter of the scale: 170 mm

Dimensions: 350 x 220 mm (LxW)

Shaft diameter: 10 mm

Weight: approx. 0.9 kg

1000761 \$184.00



Set of Aerodynamics Bodies

For measuring buoyancy and resistance to air flow of various bodies in an air current. Set of 7 wooden models with a shaft, in storage box.

1000760 \$128.00

Includes:

- 1 Streamlined body, smooth, l = 120 mm
- 1 Streamlined body, rough, l = 120 mm
- 1 Ball, d = 50 mm

- 1 Circular disc, d = 47 mm
- 1 Circular disc, d = 68 mm
- 1 Plate, 150 x 40 mm
- 1 Wing profile, l = 150 mm

Air Flow Generator

For demonstrating air flow patterns around bodies of different shapes. The air flow patterns can be projected on to a wide screen using an overhead projector. Two strings are fastened on one side at equal distances between two glass plates. The strings move according to the air currents between the two glass plates. Bodies of different shapes can be introduced in the air current. The inserted bodies can be moved to various positions in the air current from outside.

Dimensions: 385 x 310 x 75 mm

Weight: approx. 3.2 kg

1000765 \$806.00

Additionally Required:

For **1000765**

Variable Air Supply **1000605 \$552.50**

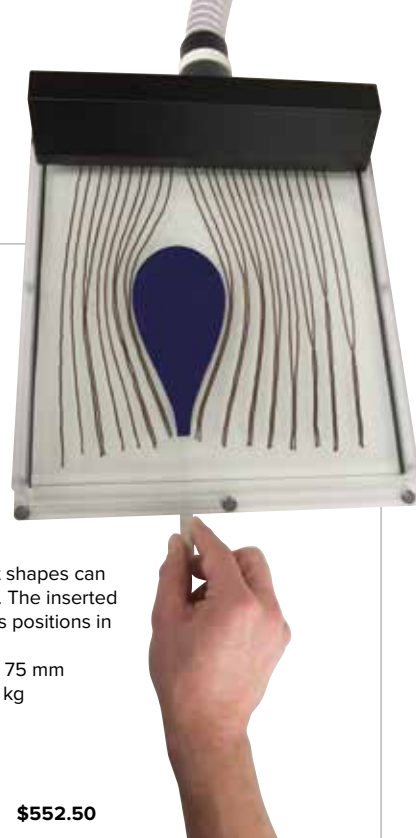

Laminar Flow Apparatus

Used for demonstrating and investigating the laminar flow properties of water. The emergence of currents in water, the flow of current in the case of straight laminar flow and the overflow of differently shaped bodies can be studied. A constricted flow of current can also be demonstrated clearly.

A rectangular piece of velour paper is placed in the apparatus consisting of an upper and lower trough. Due to capillary forces, water from the upper trough is drawn in by the paper. The water flows down into the velour paper. The flow of water in the upper level is marked with a dye at constant intervals. The low speed of flow (approx. 2 mm/s), the development of currents can be observed with the help of the dye. After the velour paper has been dried, a lasting current pattern remains, which can be copied and evaluated.

Dimensions: 220 x 140 x 240 mm (LxWxH)

Weight: approx. 1.3 kg

1006784 \$208.00

ACOUSTIC & WAVE THEORY

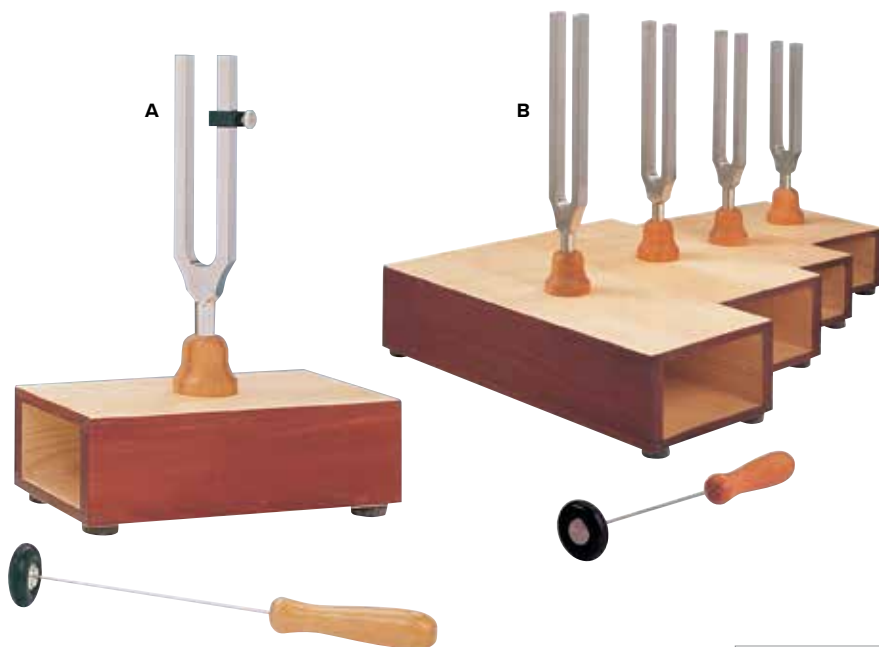

A. Tuning Fork, 440 Hz, on resonance box

We mounted a heavyweight 440 Hz tuning fork atop a clear-grain fir resonance box. The combination produces strong tones ideal for experiments in a large classroom or lecture hall. Complete with tuning weight and soft striking hammer. Natural frequency: 440 Hz, tuning fork measures: 18 x 9 x 5 cm in length and 20 cm in height with mount.

1002613 \$83.00

B. Set of Four C-major Tuning Forks, on resonance boxes

Set of four removable tuning forks on a wooden resonance box, for demonstrating the C-major chord, with particularly long-lasting tones. Includes a soft striking hammer.

Natural frequency: $c' = 256$ Hz, $e' = 322$ Hz, $g' = 384$ Hz, $c'' = 512$ Hz

1002615 \$398.00

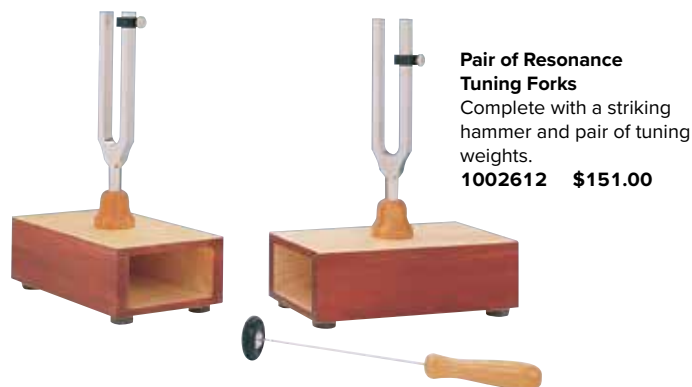

Pair of Resonance Tuning Forks

Complete with a striking hammer and pair of tuning weights.

1002612 \$151.00



Set of 8 Tuning Forks

A tuning fork is a time-honored device for demonstrating the connection between sound and vibrations, and the transfer of energy between resonant systems. This tuning fork set is made of high-quality, nickel-plated steel, and comes with its own fitted case.

Frequencies:

| | |
|---------------------------|---------------------------|
| $c' = 256$ Hz | $g' = 384$ Hz |
| $d' = 288$ Hz | $a' = 426 \frac{2}{3}$ Hz |
| $e' = 320$ Hz | $b' = 480$ Hz |
| $f' = 341 \frac{1}{3}$ Hz | $c'' = 512$ Hz |

1002605 \$185.00

Pair of Tuning Weights

Use these tuning weights to change the frequency of tuning forks for experiments; intended for the 440 Hz tuning fork on the resonance box (U10121).

1002611 \$21.00



Light Metal Tuning Fork, 1700 Hz

Suitable for use as an intensive source of high-frequency sound, e.g. for generating stationary waves in Kundt's Tube, after it has been tuned to resonance pitch.

Frequency: 1700 Hz
Length: approx. 10 cm

1002607 \$37.00

Light Metal Tuning Fork, 1000 Hz

Frequency: 1000 Hz
Length: approx. 12 cm

1002608 \$36.00



C. Hard Striking Hammer

Aluminum striking hammer. Particularly suitable for high-frequency tuning forks, for example, 2000 Hz.

1002610 \$17.00

D. Soft Striking Hammer

Rubber striking hammer. Particularly suitable for low-frequency tuning forks, for example, those on the resonance boxes.

1002614 \$18.00

> Over 2½ feet tall



E. Demonstration Tuning Fork

Used for visualizing the vibrating legs of the fork.
Length: 75 cm
1000700 \$85.00

F. 21 Hz Tuning Fork with Plotter Pen

Tuning fork that allows for plotting oscillations on a sheet of paper. The oscillation is triggered by pushing the prongs of the fork together. The oscillation of the tuning fork is highly visible both with the naked eye or with the aid of a stroboscope. Includes a plotter pen with holder and a counterweight.
Natural frequency: 21 Hz
Length: 245 mm
Total weight: approx. 170 g
1000805 \$62.00

G. Metallophone

Mounted on a base plate. C-major scale from c1 to g2. Notes, frequencies and intervals are printed on the base plate. Striking hammer included.
Dimensions: 320 x 210 mm (LxW)
Weight: approx. 510 g
1000804 \$89.00

H. Tuning Fork with Recording Stylus

Used for demonstrating and recording the vibrations of sound. For recording the oscillations on a sooted glass plate one of the two prongs has a pointed, metal nib. Complete with glass plate.
Characteristic frequency: 128 Hz
Total length: approx. 28 cm
1002606 \$56.00

I. Organ Pipe with Sliding Piston

An organ pipe provides a simple but effective demonstration of a resonant cavity and the relationship between cavity length and resonant frequency. This wooden organ pipe has a sliding piston so you can vary the length of the resonant cavity to provide tones of varying pitch. The pipe will produce frequencies from approximately 400 to 800 Hz.
Frequency range: g1 (392 Hz) to g2 (794 Hz)
Resonance space:
Area: 24 x 24 mm
Length: approx. 180 mm
Length with piston fully extended: approx. 550 mm
1009924 \$69.00

Digital Sound Meter

Features:

- +/- 2dB accuracy with 0.1dB resolution
- A&C weighting
- AC analog output
- Record max/min values over time
- Auto power off and Max Hold functions
- Utilizes 0.5" (12.7 mm) condenser microphone
- Tripod mountable
- 40 to 130 dB measuring range
- Fast/slow response time
- Complete with 4 AAA batteries and microphone windscreen

Dimensions: 9 x 2.2 x 1.7" (230 x 57 x 44 mm)

Weight: 5.6 oz (160g)

3004199 \$89.99



Tuning Fork, 2000 Hz

Made with a handle for demonstrating the Doppler effect, which can be exhibited very impressively by moving the fork slowly toward and away from the audience.

Natural frequency: 2000 Hz

Length of the tuning fork: 220 mm

1002609 \$71.00

Additionally Required:

Hard Striking Hammer

1002610 \$17.00



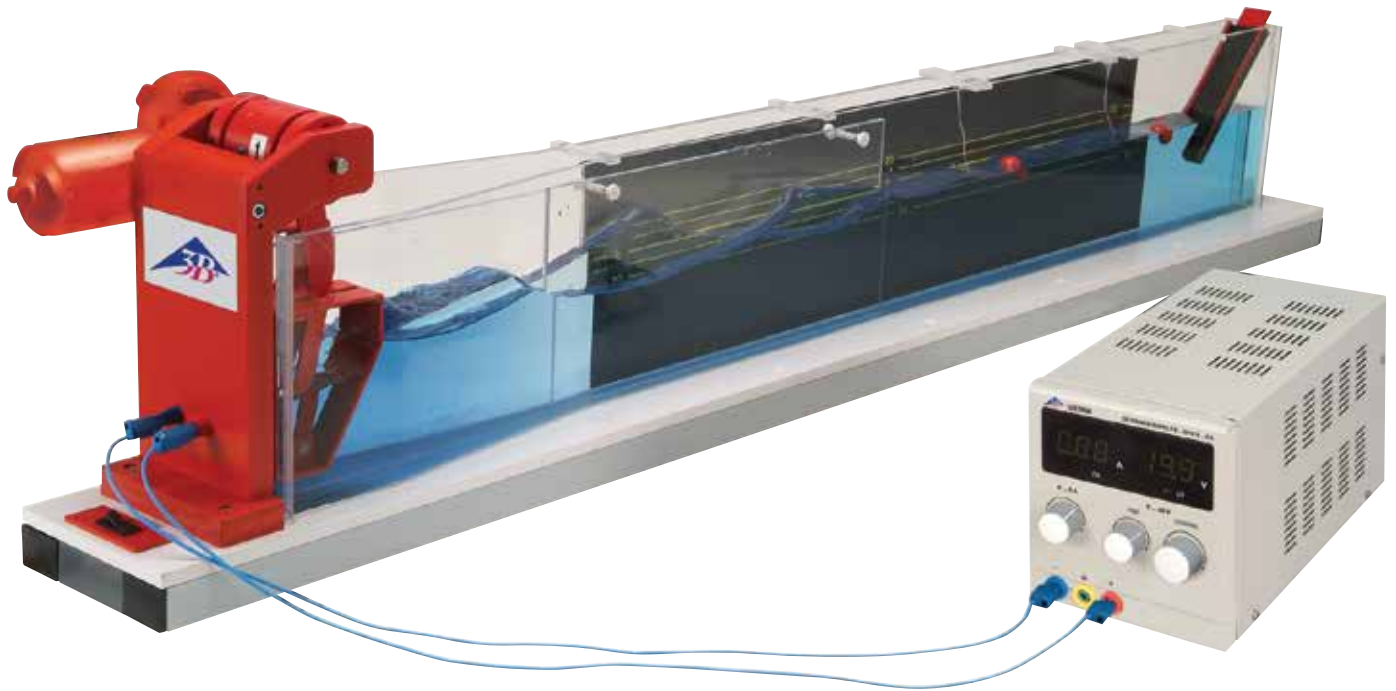

Experiment Topics:

- Reflection
- Dispersion
- Interference
- Frequency
- Wavelength

Wave Channel for Water

Demonstrate and investigate the wave properties of water with our new wave channel. The unit has a Y-shaped channel made of plexiglass with two wave exciters which can be used both in-phase and out-of-phase. By adjusting the frequency you can generate waves with varying wavelengths. Waves can be either absorbed or reflected by inserting or removing the absorber at the end of the channel.

1000807 \$2,645.00

Additionally Required:

DC Power Supply 1003311 \$348.00

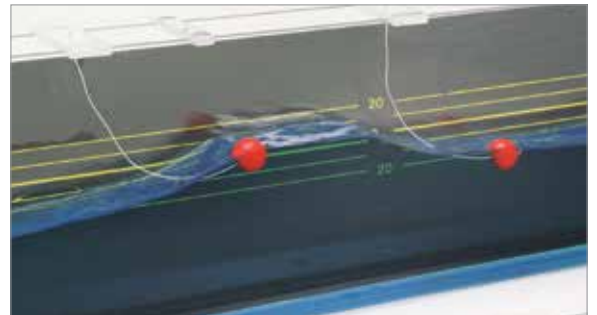

Ripple Tank

Equipment set for the graphic demonstration of fundamental phenomena found in wave theory based on waves made visible in water. The wave tank consists of a flat basin with a glass bottom set in an aluminum frame. The generation of waves in water is carried out by transferring the oscillations of an electromagnetic vibrator. The control unit is responsible for separately regulating both the frequency of the stroboscope as well as the frequency and amplitude of the vibrator.

Supply voltage: 9 V - 12 V via 4-mm safety sockets

Light source: LED lamp 12 V / 100 W, GY6.35

1017591 \$1,171.00

Additionally Required:

DC Power Supply 1003311 \$348.00

Kundt's Tube E

Sound tube made of transparent acrylic with loudspeaker and movable scale for quantitative investigation of sound waves in air or other gases, in particular for measurement of wavelength and speed of sound. With two stand bases, capillary disc, sensor disc, two hose connectors with stopcock for filling with gas, fitting and guide for long microphone probe, hole for short microphone probe, plus holder and connector for heating rod K.

Frequency range: 20 to 5000 Hz
 Length of sound tube: 1000 mm
 Diameter of sound tube: 70 mm
 Scale: 950 mm
 Hose connectors: 5 mm diameter
 Speaker power output: 2 W Impedance of speaker 50 Ω
 approx. 1.25 kg

Weight:
1017339 \$427.00

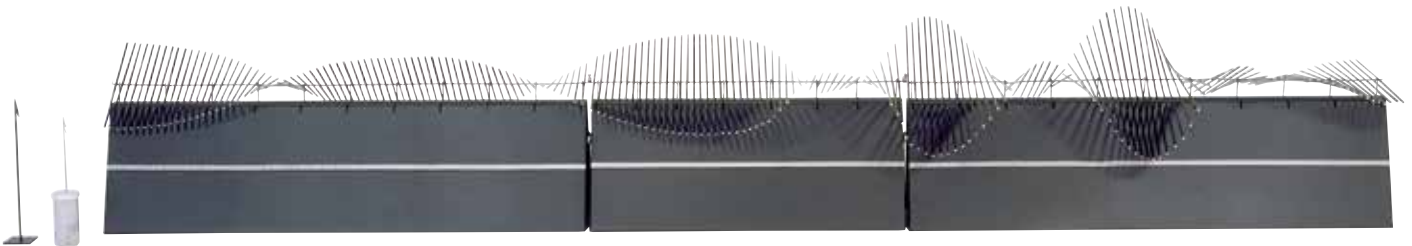

Demonstration Wave Machine, single module
 The single module can be used to perform demonstrations, except for reflections at transitions and transition coupling including Module, Damping device, & Retention clip on a rod.
1003492 \$350.00

Demonstration Wave Machine, triple module

This wave machine is intended for conducting a wide range of experiments to demonstrate the behavior and properties of transverse waves. The wave machine consists of three A-shaped modules which are made of sheet steel, and can be coupled together and folded for the purpose of storage. The steel rods for representing wave motion are soldered to a steel-rod spring on this structure. The rod ends are furnished with fluorescent paint on one side and white paint on the other side. The equipment set also includes a damping device, a retention clip for demonstrating reflections (fixed ends) as well as two module couplers.

Dimensions:

Module 1: 92 cm long with 73 rods each 46 cm long
 Module 2: 92 cm long with 73 rods each 23 cm long
 Module 3: 60 cm long with 47 rods, 46 cm long at one end, 23 cm long at the other end
 Total length: 2.44 m
1003491 \$895.00

Hand-Held Wave Machine

For demonstrating the propagation, reflection, refraction and superimposition of transverse waves. A chain of double pendulums is coupled by means of a bifilar torsion strip. Pendulum bobs for altering the moment of inertia are included in the scope of delivery. Two handles are used for manual excitation. 79 double pendulums.
1003524 \$171.00

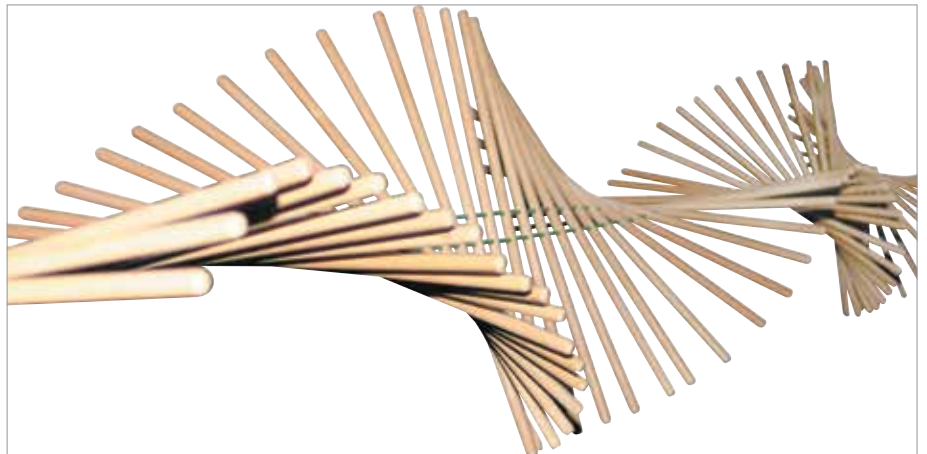



Acoustic Demonstration Kit

For presenting a comprehensive overview on the field of acoustics. Delivery in a plastic tray with foam liner to enable protective storage of the individual components. The demonstration apparatus includes 34 components and devices.

1000816 \$791.00



Three-String Monochord

Used for experiments with vibrating strings, e.g. for investigating the dependence of pitch on the length, tension and thickness of a string. Contains three strings stretched across a resonance body. Two of the strings can have their length and tension adjusted via a bridge and thumbscrew respectively. The third string has a guide pulley and hook which can be attached to a spring scale and fitted with weights to measure the string tension.

Scale length: 60 cm
 Scale division: cm and dm
 Dimensions: 70 x 9 x 6.5 cm
1002959 \$179.00

Additionally Required:

Set of 3 Monochord Strings 1002960 \$34.00

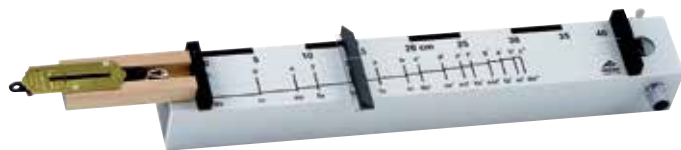

One-String Monochord

A wooden box, open on both sides, with clamping fixture for a string and reading device for the string tension.

Dimensions in mm: 490 x 70 x 60 (LxWxH)

Includes:

- Monochord
- Monochord Bridge
- Steel string (B)
- Perlon string (B)

1000806 \$239.00

Additionally Required:

Set of 3 Monochord Strings 1002960 \$34.00



Horn Loudspeaker

Point sound source for acoustic experiments e.g. for the excitation of Kundt's tube U8432845. The exit aperture of the loudspeaker can be used on the tube directly and is thus better suited than a larger loudspeaker. Barrel foot not included.

Frequency range: 300 Hz to 10 kHz
 Power rating: 6 W (max 10 W)
 Impedance: 8 Ohm
 Stationary diameter: 10 mm ϕ

1000811 \$170.00



Helmholtz Resonator

Hollow glass bulb with a narrow tube leading out for demonstrating acoustic resonance. The fundamental oscillation is generated by blowing into the opening or tapping on the outside of the bulb. The elasticity and inertial mass of the air in the bulb cause the bulb to act as an acoustic resonator with a highly distinct resonant frequency. The frequency is dependent on the dimensions of the bulb and the tube. With a whole set of Helmholtz resonators it is possible to demonstrate how tones combine to form a tonal mixture.

Opening on the glass bulb: 14 mm dia.
 Length of tube: 15 mm
 Internal diameter of tube: 6 mm

70 mm dia. 1003520 \$31.00
52 mm dia. 1003521 \$25.00
40 mm dia. 1003522 \$20.00
32 mm dia. 1003523 \$19.00

Vibration Generator

Used for experiments studying oscillations and resonance. Springs, plates, rubber bands, and other accessories can be attached and made to vibrate. The generator is encased in a robust plastic housing which includes a mounting pin with 4-mm socket for accessory attachment (Chladni plates, resonance wire, rubber band etc.). Also includes a holder for a stand rod (up to 8 mm \varnothing) on the rear side of the apparatus to demonstrate standing waves in a coil spring. The generator is equipped with overload protection.

Connection: Via 4-mm safety sockets
 Impedance: 8 Ohms
 Frequency range: 0 up to 20 kHz
 Overload protection: 1 A fuse
 Dimensions: 200 x 160 x 70 mm
 Weight: 1.4 kg

1000701 \$246.00



Recommended Accessories:



Rubber Band

Used for demonstrating stationary waves and wave propagation using the vibration generator U56001. 25 m, 2 mm \varnothing .

1000702 \$15.00



Chladni's Plates

Used for demonstrating Chladni's acoustic figures with fine, dry sand. Plates with 4 mm plugs.

Chladni Plate, square, 180 x 180 mm

1000706 \$46.00

Chladni Plate, circular, 240 mm \varnothing

1000705 \$56.00

Kinetic Gas Theory

Used for demonstrating the relationship between temperature, pressure and volume and elucidating molecular movements as a function of the state of aggregation. Differently colored balls (model gas) are put into a state of motion by a mechanical wave exciter. Includes: Plexiglass cylinder, 30 cm long; disc; and one set of colored balls.

1000704 \$71.00



Power Function Generator

Sine and square wave generator especially well-suited for student and demonstration experiments. Illuminated, digital display for frequency and signal shape. Built-in amplifier is controlled with the volume knob.

Signal wave: Sine, square, positive square-wave
 Frequency range (1): 0.05 Hz - 3 kHz
 Resolution: 0.05 Hz
 Frequency range (2): 1 Hz - 50 kHz
 Resolution: 1 Hz
 Output voltage: 0 - ± 12 V continuously adjustable, short-circuit proof

Output current: Max. 1 A
 Connection: Via 4 mm-safety sockets
 Power consumption: Max. 15 VA
 Dimensions: 45 x 195 x 115 mm
 Weight: 1.2 kg

1009956 \$991.00

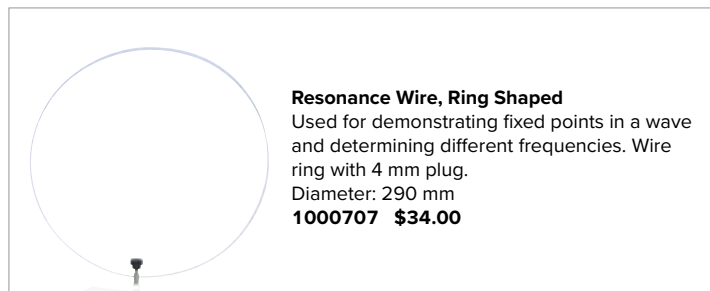

Resonance Wire, Ring Shaped

Used for demonstrating fixed points in a wave and determining different frequencies. Wire ring with 4 mm plug.

Diameter: 290 mm

1000707 \$34.00

Accessories for Spring Oscillations

Used for the demonstration of standing waves in a coil spring used in conjunction with the vibration generator U56001. Consisting of angled stand rod, coil spring and connector pin for attachment of the spring to the vibration generator.

Rod: 470 x 8 mm \varnothing
 Spring constant: 3.9 N/m

1000703 \$92.00

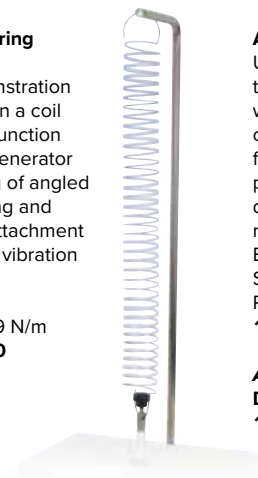

Accessories for Rope Waves

Used for investigating standing transverse waves and their wavelengths as a function of rope tension at constant frequency. Consists of a base plate with stand rod, holder for dynamometer, pulley and rubber rope.

Base plate: 180 x 180 x 25 mm
 Stand rod: 525 mm

Rope: 1 m

1008540 \$112.00

Additionally Required:

Dynamometer

1003105 \$27.00



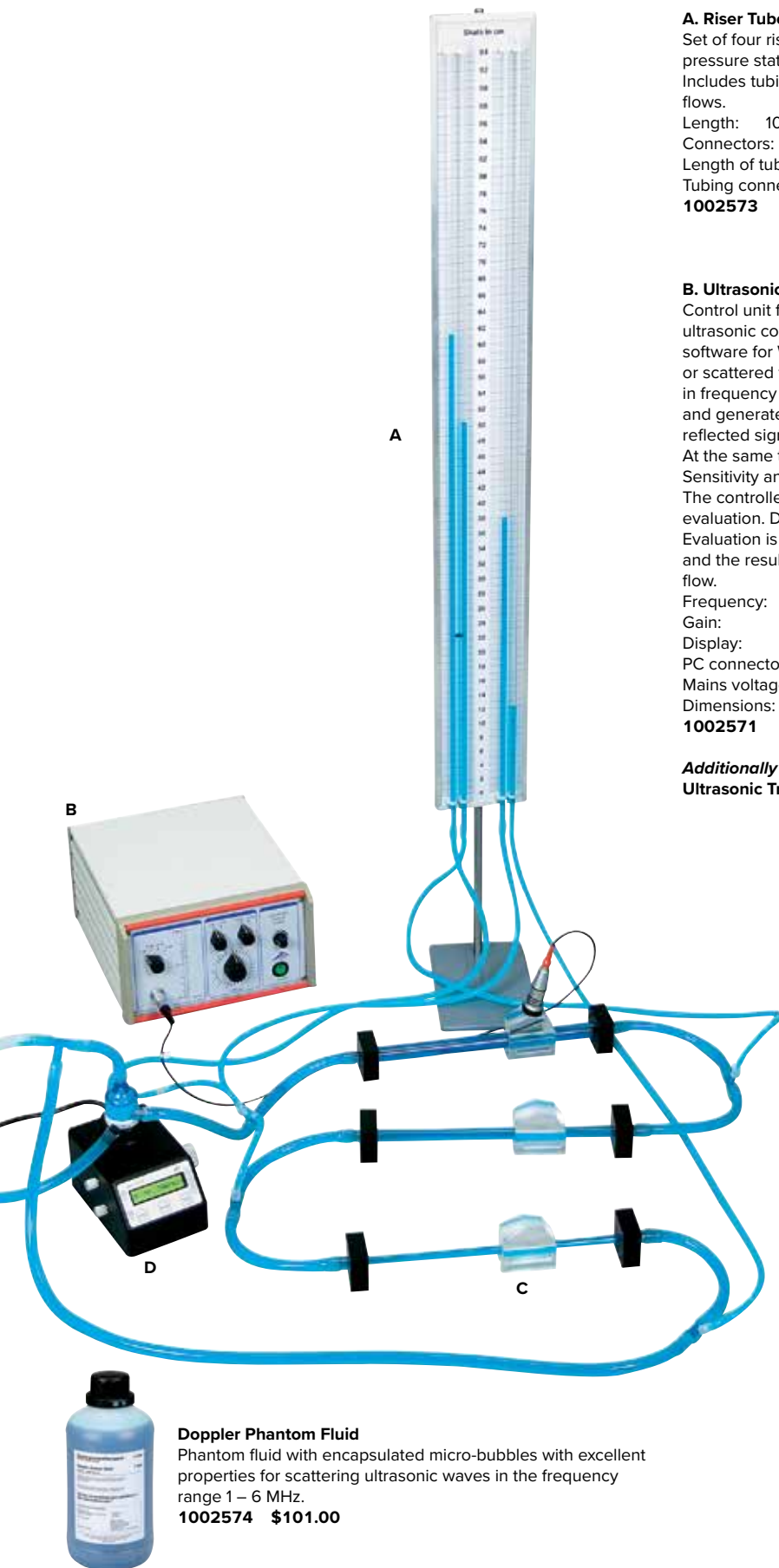

A. Riser Tubes for Pressure Measurement

Set of four riser tubes arranged in front of a millimetre scale for measuring pressure status at up to four measuring points along the line of a flow. Includes tubing and Luer Lock connectors to make a circuit in which the fluid flows.

Length: 1000 mm
 Connectors: Luer Lock, male
 Length of tubing: 1200 mm
 Tubing connector: 3/8" female Luer Lock connector
1002573 \$531.00

B. Ultrasonic Doppler Pulse Generator

Control unit for conducting ultrasonic Doppler experiments using 2 MHz ultrasonic converter (U10016). Includes measurement and evaluation software for Windows operating system. If the radiated waves are reflected or scattered from moving particles or bubbles in fluid flow, the Doppler shift in frequency can be detected. The equipment detects the scattered waves and generates an audio signal at a volume that reflects the amplitude of the reflected signal and a frequency that reflects the speed of the scattering. At the same time, the amplitude is also displayed on an LED bar display. Sensitivity and volume can be adjusted by means of appropriate controls. The controller can also pass on data to a PC for detailed recording and evaluation. During measurement the current LF Doppler signal is displayed. Evaluation is by means of a Fourier transformation in the frequency domain and the result can be interpreted as the distribution of velocity within the flow.

Frequency: 2 MHz
 Gain: 10 – 40 dB
 Display: LED bar display and acoustic signal with volume control
 PC connector: Parallel, LPT, Sub D 25
 Mains voltage: 90 – 230 V, 50/60 Hz
 Dimensions: approx. 256 x 185 x 160 mm³
1002571 \$6,871.00

Additionally Required:

Ultrasonic Transducer 2MHz 1002582 \$1,002.00

C. Flow Tubes and Hose Equipment Set

Equipment set including plastic tubes and hoses of various diameters and lengths for investigating flow phenomena using ultrasonic waves. Includes Doppler prisms for connecting an ultrasonic transducer to the tubes or hoses at three different angles.

1002572 \$1,354.00

D. Centrifugal Pump

Fluid pump for generating adjustable constant fluid velocity for investigating flow phenomena in a good approximation of laminar flow. The magnetic transmission of motor power to the pump head means the fluid is completely isolated from the drive module. To generate pulsing flows, the pump can be operated with a periodic signal.

1002575 \$2,314.00

Doppler Phantom Fluid

Phantom fluid with encapsulated micro-bubbles with excellent properties for scattering ultrasonic waves in the frequency range 1 – 6 MHz.

1002574 \$101.00

Experiment Topics:

- Propagation of longitudinal and transverse ultrasonic waves in solid bodies
- Determining velocity of longitudinal and transverse ultrasonic waves in solid bodies
- Determination of shear modulus, modulus of elasticity and Poisson number
- Attenuation of sound in solid bodies and liquids
- Frequency dependence of sound attenuation
- Time-dependent gain
- Frequency dependence of resolution
- Recording brightness images
- Recording ultrasonic echoes from moving boundaries (time-motion mode)
- Measurement of anomalies



1018616



Laptop not included



1018617
(pg. 159)

1002584
(pg. 159)

Ultrasonic Echoscope GS200

Operational device for conducting ultrasonic experiments in reflection mode (pulse echo) or in through-transmission mode with ultrasonic probes 1 MHz (1018617), 2 MHz (1018618) and 4 MHz (1018619). With the built-in transmission and receiving unit, time gain control (TGC), integrated analogue-digital converter and microprocessor for connection to the measuring and evaluating computer via the USB interface. Connection of the ultrasonic probes via robust snap-in sockets with automatic probe recognition. Compensation for losses of intensity in ultrasonic sound pulses passing through solid or liquid bodies by means of TGC with selectable threshold, start point, end point and TGC ramp. The most important function signals (trigger, TGC, A-scan signal (amplitude signal) and ultrasound signal) are available via BNC sockets on the front of the device. Includes measurement and evaluation software for Windows operating systems. Screen display of the ultrasound signals (echogram) and the simultaneous TGC signal, whereby the A-scan signal and ultrasound signal can be recorded individually or both simultaneously in the echogram as a function of time or penetration depth. Display of all currently set system parameters (operating mode, transmission level, gain, connected ultrasound probes) calculation of frequency and cepstrum of ultrasound signal (FFT), depiction of 2-dimensional ultrasonic images (B-image) and the time characteristic of time motion reflection layers (time-motion methods). Ultrasonic probes not included in scope of delivery.

1018616 \$6,956.00

| | |
|----------------------|--|
| Frequency range: | 1 – 5 MHz |
| Transmission signal: | Dirac pulse (< 1 μ s, 0 – 300 V) |
| Transmission power: | 0–30 dB, in 5 dB steps |
| Gain: | 0–35 dB, in 5 dB steps |
| TGC: | Continuously adjustable threshold value, start value, rise time and gain time, Maximum gain of approx. 32 dB |
| Outputs (front): | TGC, trigger, ultrasound signal, A-scan signal via a BNC socket in each case |
| Probes connectors: | 2, selectable for transmit, receive or duplex modes |
| PC connection: | USB |
| Scanning rate: | 10, 25, 50 and 100 MHz |
| Power consumption: | approx. 20 VA |
| Mains voltage: | 100 – 240 V, 50/60 Hz |
| Dimensions: | approx. 226x169x325 mm ³ |

Equipment:

Equipment Set " Ultrasound in Solids" 1002584 \$451.00

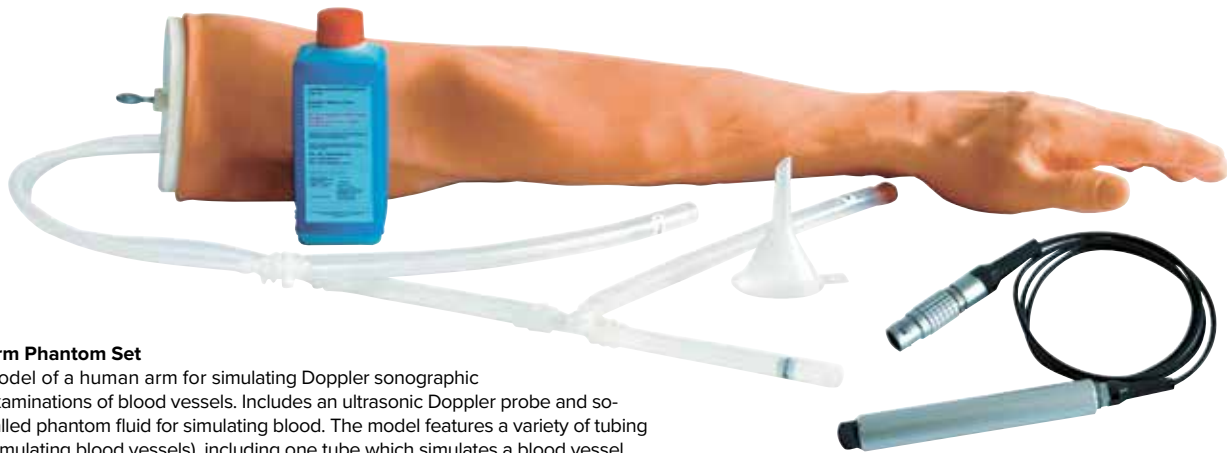

Arm Phantom Set

Model of a human arm for simulating Doppler sonographic examinations of blood vessels. Includes an ultrasonic Doppler probe and so-called phantom fluid for simulating blood. The model features a variety of tubing (simulating blood vessels), including one tube which simulates a blood vessel stricture or stenosis. Using the ultrasonic Doppler apparatus (U10001) and a centrifugal pump (U10005), it is possible to simulate typical examinations used in vascular diagnosis. Doppler spectra are measured for the flow through arteries and veins with both a pulsing flow (like a heart beat) and continuous flow, allowing sounds typical of Doppler sonography to be heard. One particularly interesting feature is the possibility of observing the change in the spectra and the Doppler sound due a stenosis (stricture) in the elbow. In addition, it is possible to calculate the flow index and resistance index from the curves measured with a pulsing flow.

Probe frequency: 2 MHz
 Probe dimensions: 200 mm x 15 mm diam.
 Length of lead: 1 m

1012880 \$2,338.00

Includes:

- Model arm with stenosis
- Silicone tubing
- 3/8" connectors
- Ultrasonic Doppler probe
- Phantom fluid to simulate blood
- 250 ml
- Funnel
- Rubber stoppers

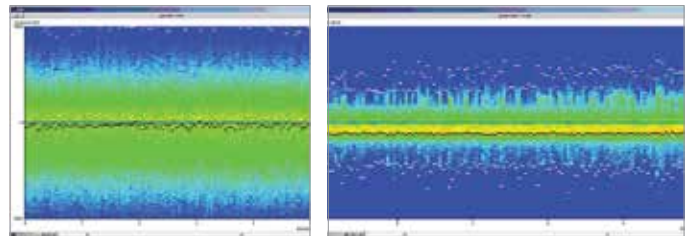

Model Eye for Ultrasonic Biometry

Model of the human eye, enlarged to a scale of 3 to 1, including the cornea, the lens and glass bodies for demonstrating the fundamentals of ultrasonic biometry. The biometric ratios in the human eye (distance between cornea and lens, thickness of lens, distance between lens and retina) are very well suited to demonstrating measurement using a pulse-echo method with ultrasound. With the help of an ultrasonic echoscope (U100101) and a 2-MHz ultrasonic probe (U10016), typical echoes and the speed of sound can be measured. This allows the geometry of individual objects in the eye to be calculated. A lesion close to the back of the eye becomes apparent due to the diffuse nature of its echo. Diameter: 80 mm



1012869 \$882.00

Additionally Required:

| | | |
|-----------------------------------|----------------|-------------------|
| Ultrasonic Echoscope | 1018616 | \$6,956.00 |
| Ultrasonic Probe 2 MHz | 1002582 | \$1,002.00 |
| Ultrasonic Coupling Gel | 1008575 | \$30.00 |
| Recommended for comparison | | |
| Model of the Human Eye | 1000259 | \$116.00 |

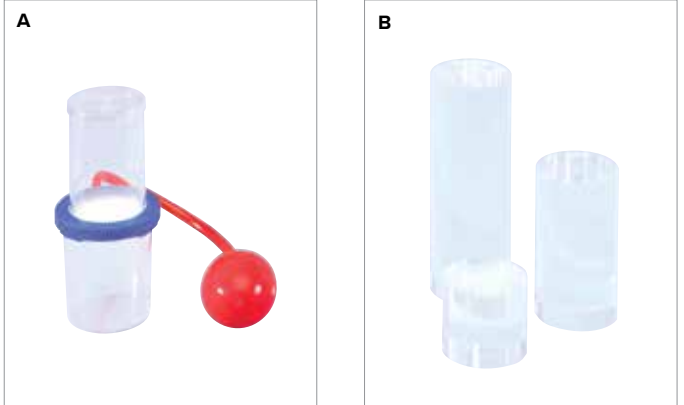

A. Heart Valve Model

Double-vessel with a rubber membrane and pressure regulator is used to demonstrate the operation of a heart valve. Tests conducted with the Heart Valve Model produce images similar to those of a beating heart's valve during echocardiography in medical diagnostics.

160 x 70 mm
1002590 \$195.00

B. Set of 3 Cylinders

These polished polyacrylate cylinders are used to ascertain the speed of sound and the attenuation of ultrasonic waves in transparent acrylic. Measurements can be performed in reflection mode or through-transmission mode.

Length : 40 mm, 80 mm and 120 mm
 Diameter: 40 mm
1002588 \$178.00

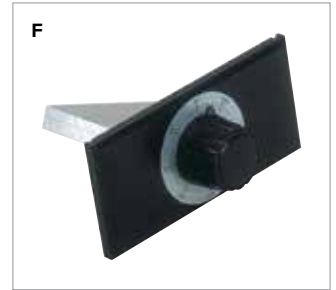
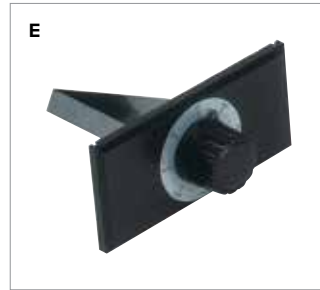
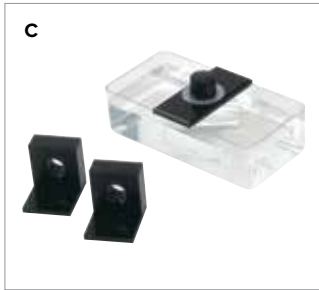

C. Ultrasound in Solids Equipment Set

Use the equipment set for the investigation of the propagation of longitudinal and transversal waves, known as shear waves. The equipment set also allows for the determination of the shear modulus, elasticity modulus and Poisson's ratio in solid bodies. Determine ultrasonic attenuation in liquids through time dependent amplitude measurement with the aluminum test block. Ultrasonic transducers are available in 1 MHz, 2MHz and 4 MHz and are not included in the scope of delivery.

Features:

- Acoustic basin
- Polyacrylic test plate with protractor scale
- Two holders for ultrasonic transducers

Sound trough: 20 x 10 x 6 cm
 Test plate: 10.4 x 7.5 x 5 cm
 Protractor scale: 360°, 5° divisions
 Polyacrylic block: 7 x 4.5 x 1 cm
1002584 \$451.00

E. Polyoxymethylene Test Block

The Polyoxymethylene Test Block is an accessory for use with the Ultrasound in Solids Equipment Set to examine the spread of transverse waves in plastic. Different properties of polyoxymethylene can be determined such as the elastic constants, the shear modulus, the modulus of elasticity and the Poisson ratio.

Protractor scale: 360°, 5° divisions
 POM block: 70 x 45 x 10 mm³
 Dimensions: 104 x 75 x 50 mm
1002586 \$245.00

D. Ultrasonic Probe, GS 200

Ultrasonic probe for investigations of penetration levels and depth resolution. It includes a 16-mm piezo-ceramic disc in a die-cast metal case, adapted to sound in water/acrylic glass, a 1 meter long cable with a frequency-coded snap-in plug.

Dimensions: 65 mm, 27 mm Ø
1 MHz 1018617 \$597.76
2 MHz 1018618 \$1,002.00
4 MHz 1018619 \$932.00

F. Aluminum Test Block

Accessory for use with the Ultrasound in Solids Equipment Set to examine the propagation of transverse waves in metals. Different properties of aluminum can be determined such as the elastic constants, the shear modulus, the modulus of elasticity and the Poisson ratio.

Features:

- High reflection coefficient in water
 - Measure attenuation in liquids
 - Protractor with scale
- Protractor scale: 360°, 5° divisions
 Aluminum block: 70 x 45 x 10 mm³
 Dimensions: 104 x 75 x 50 mm
1002585 \$249.00

➤ Measure the speed of sound in a variety of mediums!



Microphone probe, long

Miniature microphone at the end of a long rod for measuring changes in sound pressure in Kundt's tube E. With thread for attaching probe disc of Kundt's tube E.

Frequency range: 20 Hz – 16 kHz
 Diameter of rod: 6 mm
 Length of rod: 810 mm
 Connecting lead: 1 m approx., with 3.5-mm jack plugs
1017342 \$88.00



Acrylic Body with Drilled Holes

Polished polyacrylic block with bores of various diameters and varying distance from the surface. Both the 1 MHz and 4 MHz transducers are required for studying resolution.
 150 x 80 x 40 mm

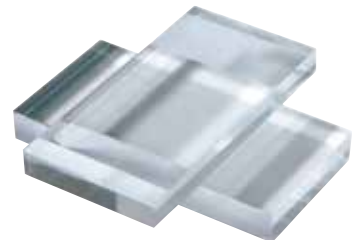

Pair of Reflection Blocks

Fine-tune your studies of sound by measuring attenuation as a function of frequency and multiple echoes from this polished polyacrylate block. A 4 MHz transducer (U10017) is especially suitable for such measurements. An echo pattern comprising at least 3 echoes is recorded, and the spectra of the individual echoes analyzed. The result of the analysis is a shift in the average frequency toward lower frequencies, due to a stronger attenuation of the signal's high-frequency components.
 80 x 40 x 10 mm
1002587 \$206.00

Experiment Topics:

- Determine the speed of sound and the attenuation of ultrasonic signals in polyacrylate
 - Localize defects
 - Investigate aberrations resulting from acoustic shadows and ground returns
 - Analyze frequency-dependent resolving power
 - Display manual B-images
- 1002589 \$205.00**

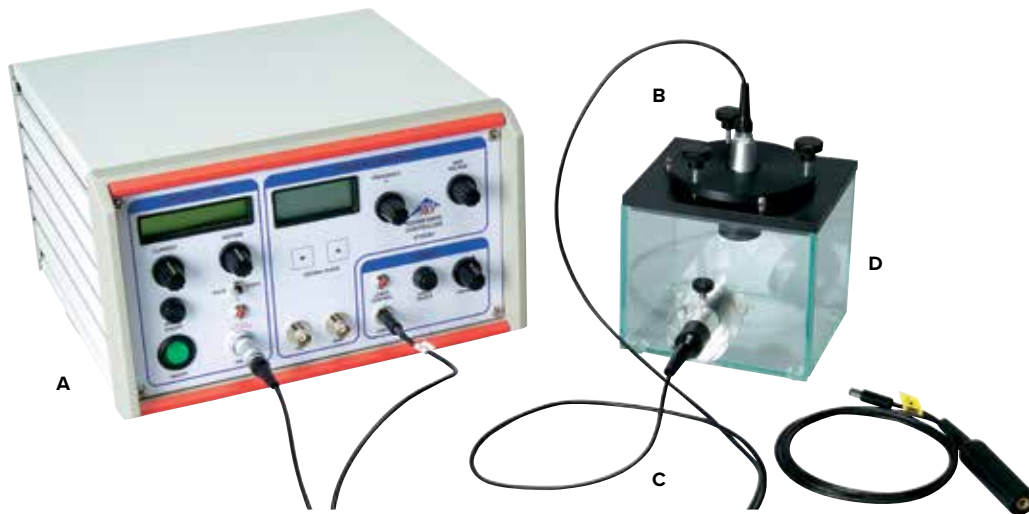

A. Ultrasonic Continuous Wave Generator

Use this apparatus to generate high-energy ultrasonic continuous waves (CW), or stationary waves. The generator's transmission power can be adjusted continuously and activated or deactivated independently via the voltage supply on the ultrasonic transducer. The integrated LCD display makes reading your measurements trouble-free.

Frequency: 2 MHz, 4MHz, 8MHz, adjustable via a selector switch
 Output signal: Sinusoidal, continuously adjustable from 5 V_{SS} to 50 V_{SS} w/ independent disconnect facility and indicator lamp

Output power: Max. 25 watt
 Connection: BNC jack
 Voltage display: 3-digit LCD
 Height of digits: 10 mm
 Monitor signal: TTL to BNC socket
 Laser output: 3 V DC, max. 300 mW at jack socket, with independent disconnect facility and indicator lamp

Dimensions: 256 x 86 x 156 mm
 Mains voltage: 115/230 V, 50/60 Hz
 Power consumption: Approximately 30 VA
 Ultrasonic transducer: Piezo-ceramic, 16 mm Ø
 Dimensions: 65 x 27 mm Ø

1002576 \$5,918.00

Additionally Required:

| | | |
|---------------------------------------|----------------|-----------------|
| Laser Diode | 1002577 | \$529.00 |
| Test Vessel | 1002578 | \$929.00 |
| Projection Screen | 1000608 | \$69.00 |
| Stand Base | 1002834 | \$32.00 |
| Laboratory Jack (160 x 130 mm) | 1002942 | \$122.00 |

B. Laser Diode for Debye-Sears Effect

Safety Class II.

Beam spot: < 6 mm Ø at a distance of 3 m
 Wavelength: 650 nm ±10 nm
 Power: < 1 mW
 Supply voltage: 3 V DC
 Current consumption: Max. 30 mA
 Connector: Jack plug, 3.5 mm Ø
 Dimensions: 80 mm x 18 mm

1002577 \$529.00

C. Ultrasonic Test Vessel

Made of transparent acrylic, the Ultrasonic Test Vessel possesses a lid and a transducer mounting. Three adjustment screws can be used to adjust the stationary wave. The device comes with a plano-convex lens on a square mounting for projection experiments.

Test vessel: ≥100 x 100 x 120 mm
 Testing volume: Approximately 1 liter
 Laser fixture: 8 mm Ø inside
 Lens: Plano-convex, f=100 mm, 16 mm Ø

1002578 \$929.00

D. Laser Diode for Debye-Sears Effect, Green

Laser diode of protection classification IIIa with 1 m connector lead and barrel connector for connecting ultrasonic cw generator (U100061).

Wavelength: approx. 432 nm
 Power: < 5 mW
 Supply voltage: 3 V DC
 Current consumption: Max. 250 mA
 Dimensions: 90 mm x 17 mm dia.

1002579 \$510.00

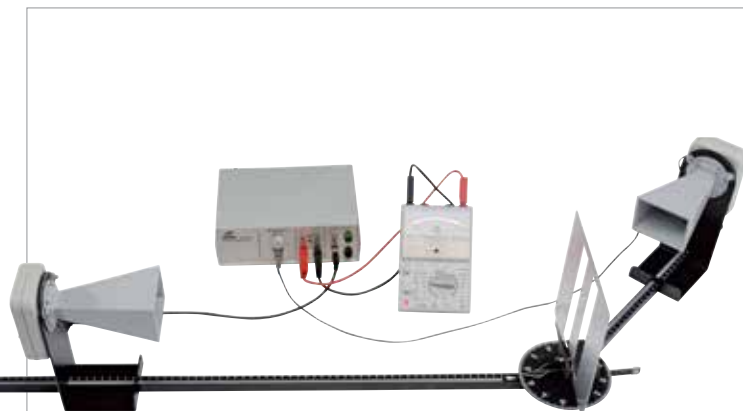

Microwave Set

Equipment set for conducting wave optics experiments involving wavelengths in the cm range. A transmitter with a horn antenna radiates a narrow beam of linearly polarised electromagnetic waves with a wavelength of about 3 cm. The direction of polarisation can be altered by rotating the antenna around the axis of propagation. To detect the waves, a horn antenna receiver and a microwave sensor are provided. A control unit converts the intensity of the signal received into a proportionally large output voltage that can be measured using a voltmeter. It is also possible to switch on an acoustic signal with a volume that is proportional to the intensity of the signal.

Oscillator frequency: 10.5 GHz (U8493600-115)
 Power of transmitter: 10–25 mW
 Internal modulator frequency: 3 kHz approx.
 Acoustic signal: Switchable
 External modulation: 100 Hz –20 kHz, 1 V max
 Output voltage: 10 V max.
 Receiver with horn antenna: Silicon diode with resonator
 Microwave sensor: Silicon diode with resonator
 Dimensions of basic apparatus: approx. 160 x 200 x 75 mm³
 10.5 GHz (115 V, 50/60 Hz)

1009950 \$1,780.00

ELECTRICITY & MAGNETISM



Electrostatics Experiments Kit

Used for vivid demonstration of important electrostatics phenomena. The set allows one to carry out a series of interesting experiments in electrostatics, including many recreations of famous historical experiments. Most parts are equipped with a 4 mm plug to mount them and are easily interchangeable on the included insulated stand. For connections to the charge source plug leads or the included metal chains can be used.

Includes:

- Insulated stand with terminal socket
- Sphere with plug, 30 mm Ø
- Moving sphere
- Pith cylinder pendulum
- Pieces of pith in box
- Housing with sphere-shaped electrode
- Housing with point-shaped electrode
- Electric whirl
- Tissue paper umbrella
- Lighting board
- Carillon
- Friction rod PVC with 4 mm bore hole
- Pair of metal chains

1000924 \$744.00



Additionally Required:

Wimshurst Machine 1002967 \$472.00
Van de Graaff Generator 1002963 \$1,158.00

Van de Graaff Generator with Discharge Electrode

Used for the generation of DC potentials with low current for multiple experiments in electrostatics. Detachable conductor sphere, drive motor with controllable speed, including small discharge sphere on rod.

Max. voltage: approx. 100 kV
 Length of sparks: Up to 5 cm
 Conductor sphere: 190 mm dia.
 Sphere on rod: 460 mm, dia. 90 mm
 Dimensions: approx. 24 x 19 x 62 cm

1002963 \$1,158.00



Deluxe Wimshurst Machine

A top-quality, hand-operated apparatus for performing electrostatic demonstrations. Designed to be "student-proof" in construction and materials. This unit is unique in that the current can be directed to the discharge spheres, the Leyden Jars or both simultaneously. For generating high DC voltages; complete with 2 Leyden jars as well as spark gap, hand-operated crank and V-belt drive.

Diameter: 31 cm
 Max. spark length: 12 cm
 Short-circuit current: approx. 30 μ A
 Base board dimensions: 29 x 36 cm
 Weight: 3.4 kg
1002967 \$472.00

Piezoelectric Charge Source

Hand-held unit used for the simple generation of safe voltages needed in electrostatic experiments. Featuring the functional principle of a piezoelectric gas lighter. With shortened earthing sleeve and 4 mm cable plug.

Charge: approx. 2 μ C
 Crystal capacitance: 100 pF
 Voltage: Max. 12 – 15 kV
 Dimensions: approx. 250 x 25 x 33 mm
 Weight: approx. 130 g

1000923 \$69.00



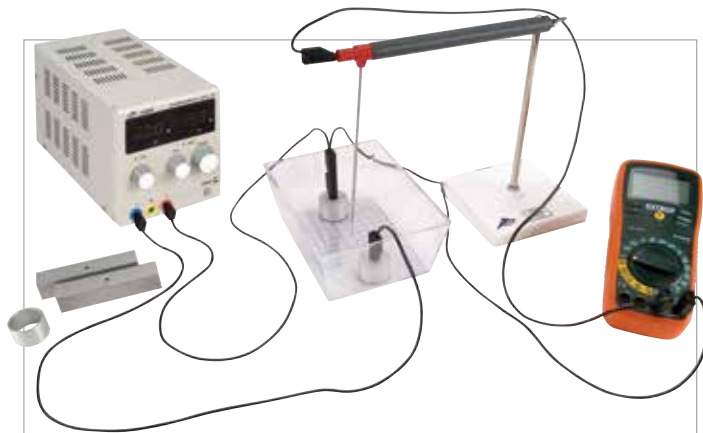

Electrolytic Trough

Equipment set for recording equipotential lines of electric fields. Electrodes of different shapes can be used to measure equipotential lines for a plate capacitor, dipole, induced surface charge and a Faraday beaker.

Includes:

- 1 Plastic trough
- 1 Stand with measurement electrode
- 2 Bar electrodes
- 2 Round disc electrodes
- 1 Ring electrode
- 20 Sheets of mm-grid paper

1009884 \$145.00

Additionally Required:

| | | |
|-------------------------|----------------|-----------------|
| Power Supply | 1003311 | \$348.00 |
| Multimeter | 3004188 | \$49.99 |
| Connecting Leads | 1002847 | \$115.00 |

Equipotential Lines of Point Charges

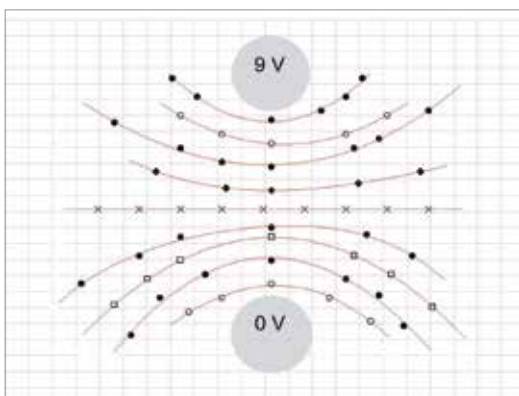
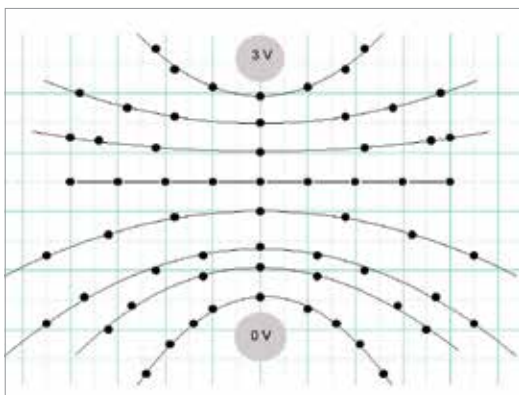

Kolbe's Electroscope

This quantitative electrostatic instrument allows you to take readings of charge magnitude. It features a glass and metal housing with 4mm sockets for grounding purposes. The pointer is mounted on a pivot bearing and is electrically insulated from the metal housing. A transparent scale allows reading of the electrical charge. For classroom demonstration experiments the electrostatic instrument is suitable for shadow projection.

1001027 \$269.00



Charge Spoon

Metal plate on insulating rod for charge transport and for experiments on electrostatic induction.

| Item Number | Description | Length | Plate | Rod Ø | Price |
|----------------|-------------|--------|------------|-------|----------------|
| 1002707 | Spoon | 205 mm | 40 x 35 mm | 10mm | \$19.00 |
| 1002708 | Spoon | 265 mm | 40 x 70 mm | 10 mm | \$19.00 |

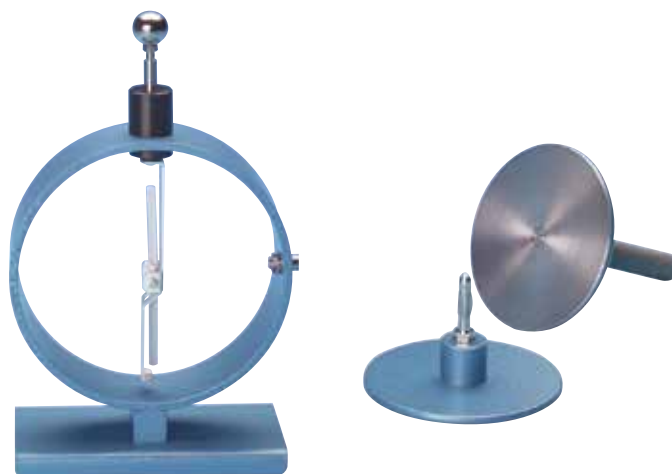

Electrostatic Demonstrator

Provide a classic introduction to electrostatics with our sturdy electrostatic demonstrator. When charged, the conductive rod rotates, indicating charge magnitude. The shield ring measures 13 cm in diameter and is constructed of powdered finish steel. The shield ring can be grounded with banana plug connectors. A Charge Sampler and a Capacitor Plate is included.

1003048 \$201.00



Friction Rods

Two rods for experiments on frictional electricity, made of PVC and acrylic.

Length: 250 mm

Diameter: 10 mm

1002709 \$17.00



Plate Capacitor, 175 cm²

This device is used to investigate the relationship between charge, voltage and capacitance, as well as determine the dielectric and electric field constants. It consists of a fixed plate and a movable plate on a guide rail. A centimeter scale is used to read the plate spacing. The device comes with four dielectric sample plates made of acrylic, bakelite, plywood and cardboard.

Plate spacing: 0 - 150 mm

Plate diameter: 149 mm

Plate area: 175 cm²

Connection: Via 4-mm safety jacks

1003232 \$193.00



Set of Conductors and Non-Conductors

Samples of eight materials for experiments to investigate the electrical conductivities of different materials. In a storage container.

Materials:

Iron, aluminium, copper, steel, wood, glass, plastic, cotton

Length: approx. 200 mm

1000948 \$193.00



Sphere with Plug

For experiments on electrostatics, e.g. for determining the capacitance of a sphere, and for experiments on electrostatic induction. Hollow brass sphere, nickel-plated with 4 mm-plug.

Diameter : 30 mm

1001026 \$25.00



High Precision Resistors

High precision resistors in plastic housing with 4 mm safety plugs.

Dimensions: approx. 122 x 70 x 30 mm³



Faraday cup

Aluminum cup for investigating the charge distribution in the case of a hollow metal body, with 4 mm-plug for placing on electroscopes.

Connection: 4 mm-plug

Height: 105 mm

Diameter: 58 mm

1000972 \$47.00

| Item Number | Resistance in Ω | Current Rating in A (continuous) | Current Rating in A (continuous) | Price |
|----------------|------------------------|----------------------------------|----------------------------------|-----------------|
| 1003062 | 1 | 18 | 25 | \$290.00 |
| 1003063 | 3.3 | 10 | 12 | \$218.00 |
| 1003064 | 10 | 5.7 | 8 | \$218.00 |
| 1003065 | 33 | 3.1 | 4.4 | \$218.00 |
| 1003066 | 100 | 1.8 | 2.5 | \$187.00 |
| 1003067 | 330 | 1.0 | 1.4 | \$188.00 |
| 1003068 | 1000 | 0.57 | 0.8 | \$180.00 |
| 1003069 | 3300 | 0.31 | 0.44 | \$180.00 |

Have questions about our products?
Contact us at **1.866.448.5846** or visit **3bscientific.com**

Experiment Topics:

- Basic operational tests
- Electrostatic tests
- Measurement of static electric field strength
- Capacitor tests
- Measurements of potential with an electrostatic meter

A. Electric Field Meters

A star-shaped modulation vane-wheel connected to earth is mounted a short distance in front of a measurement electrode, also star-shaped. Influenced by the electric field, the charges generate an alternating current proportional to the field strength. A selective amplifier measures this alternating current without the electric field experiencing any average energy loss over time. The device is protected against excess voltage.

Specifications:

Alternating output Voltage: Max. 10 V
 Measuring ranges: 100 V/cm, 300 V/cm, 1000 V/cm
 Capacitor plate: 178 mm Ø with 50 mm bore

Includes:

- 1 Electric field meter
- 1 Capacitor plate
- 1 Voltage measurement plate, measuring range 1x
- 1 Voltage measurement plate, measuring range 10x
- 1 Experiment description

1001029 \$1,142.00

Additionally Required:

B. Multimeter 3004188 \$49.99
C. Holding Rod 1002710 \$14.00

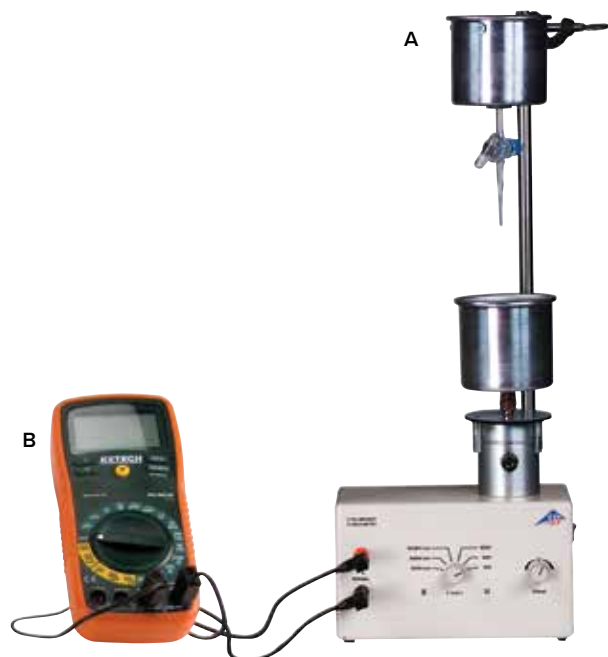
**Permanent Magnet with Adjustable Pole Spacing**

This permanent magnet has an adjustable pole spacing and a high field strength arising from a use of two neodymium magnet elements. It comes with a black-finished iron yoke, knurled handles made of high-grade steel and attachable pole shoes. This magnet system can be installed horizontally or vertically.

Dimensions:

Magnet: 20 x 10 mm
 Pole shoes: 20 x 50 mm
 Pole spacing: 2 – 80 mm
 Field strength at center of gap: 20 mT – 1000 MT

1002660 \$419.00



Electrometer

Impedance converter with high-resistance input for measuring extremely small charges and currents. The input signal is converted into a proportional voltage, which can then be measured with an external voltmeter. Includes a 12-V AC plug-in power supply.

- Electrometer gain factor: 1.00
- Input resistance: $>1,012 \Omega$
- Output resistance: $<1 \text{ k}\Omega$
- Input current: $<10 \text{ pA}$
- Input capacitance: $<50 \text{ pF}$
- Max. output voltage: $\pm 8 \text{ V}$
- Resistance to excess voltage: 1 kV (from low-resistance sources)
10 kV (from high-resistance sources)
- Supply voltage: 12 V AC

1001024 \$258.00

Additionally Required:

Electrometer Accessories 1006813 \$214.00

DC Power Supply 450 V 1008534 \$435.00

(115 V, 50/60 Hz)

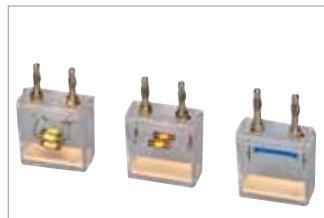

Electrometer Accessories

Set of accessories for carrying out basic experiments on electrostatics, electricity and the photoelectric effect in combination with an electrometer (U8531408-115) and 450-V DC power supply (U8521400-115).

Contents:

- 1 Faraday cup
- 1 Pair of friction rods
- 1 Metal rod with 4 mm drilled hole
- 1 Safety adapter socket
- 1 SK plug-in capacitor 1 nF
- 1 SK plug-in capacitor 10 nF
- 1 SK plug-in resistor 100 M Ω
- 1 SK plug-in resistor 1 G Ω
- 1 SK plug-in resistor 10 G Ω
- 1 Zinc electrode
- 1 Grid electrode

1006813 \$214.00

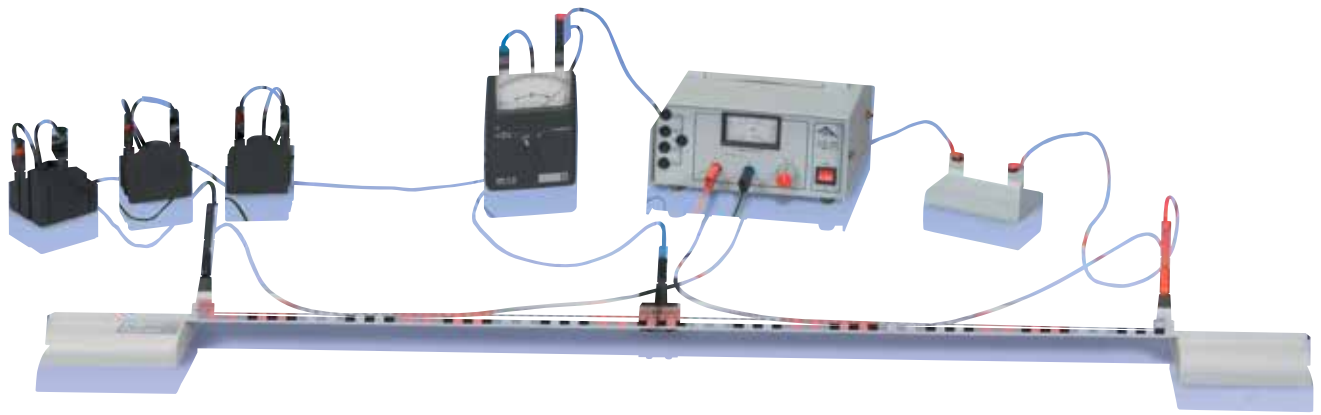

Deluxe Wheatstone Bridge

This device is used to measure resistances in bridge circuits and investigate voltage drops across wires. It consists of a rail with a scale mounted at two points and a resistance wire stretched between two connecting sockets. A sliding contact on the resistance wire is used to set the resistance of the resultant two wire sections. A Wheatstone bridge circuit is configured to determine unknown resistances. The device is only suitable for low voltages.

Dimensions: 1,300 x 100 x 90 mm
 Rail: 30 x 30 mm
 Scale: 0 – 1000 mm
 Scale divisions: mm
 Resistance wire: 1 m, 0.5 mm Ø
 Material: NiCr
 Resistance: 3 Ω
 Connection: w4-mm safety jacks
 Maximum permissible voltage: 8V
 Maximum permissible current: 1.5 A
1009885 \$217.00

Additionally Required:

| | | |
|---|----------------|-----------------|
| DC Power Supply 0 to 20V, 5A | 1003311 | \$348.00 |
| Zero-point Galvanometer | 1002726 | \$567.00 |
| Resistance Decade | 3004205 | \$109.99 |
| High Precision Resistor | 1009843 | \$30.00 |
| High Precision Resistor 100K ohm | 1000686 | \$30.00 |



Magnetic Field Lines Device, Three-Dimensional

For the three-dimensional demonstration of the magnetic field of a round bar magnet. This Plexiglas object has a center hole and features a special highly viscous fluid and iron filings. When the magnet is inserted, the evenly distributed iron filings inside the fluid align themselves in accordance with the magnetic field lines. An enclosed air bubble ensures that a good shake of the device causes the iron shavings to be evenly distributed.

Dimensions: 115 x 115 x 120 mm
 Diameter of the hole: 21 mm
 Weight: 0.8 kg
1009765 \$182.00

Additionally Required:

Round Bar Magnet (50 x 20 mm) 1003556 \$27.00

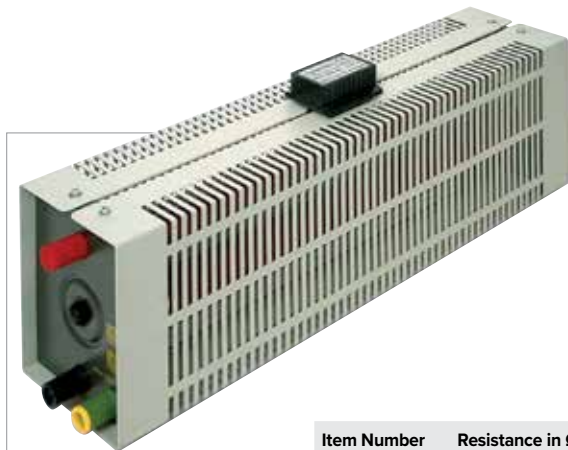

Rheostats

Used during experiments in extra-low and low voltage circuits, these heavy-duty variable resistors have shockproof housings and built-in ground sockets. Use them as a continuously variable series resistor, for setting power levels, as fixed resistor or as voltage divider.

Resistance tolerance: 10% from nominal value
 Max. permissible power: 320 W (continuous operation), 640 W (max. 15 min)
 Max. permissible voltage: 600 V
 Terminals: 4 mm safety sockets

| Item Number | Resistance in Ω | Current Rating in A (continuous) | Current Rating in A (continuous) | Price |
|----------------|-----------------|----------------------------------|----------------------------------|-----------------|
| 1003062 | 1 | 18 | 25 | \$290.00 |
| 1003063 | 3.3 | 10 | 12 | \$218.00 |
| 1003064 | 10 | 5.7 | 8 | \$218.00 |
| 1003065 | 33 | 3.1 | 4.4 | \$218.00 |
| 1003066 | 100 | 1.8 | 2.5 | \$187.00 |
| 1003067 | 330 | 1.0 | 1.4 | \$188.00 |
| 1003068 | 1000 | 0.57 | 0.8 | \$180.00 |
| 1003069 | 3300 | 0.31 | 0.44 | \$180.00 |

Bell, Relay and Bimetallic Switch Assembly Kit

Equipment kit comprising materials to assemble electromagnetic switches and bimetallic switches.

Base plate: 200 x 140 x 40 mm

Weight: 1.6 kg

Contents:

- 1 Stand plate with 3 clamps
 - 1 Bell, 70 mm in diameter
 - 2 Contact rod with three 4 mm cross holes
 - 1 Leaf spring with connector
 - 1 Bimetallic strips with connector
 - 1 Armature with connector
 - 1 Contact pin with connector
 - 1 U-core, 20 mm²
 - 1 Coil, 500 turns
- 1000994 \$251.00



Digital Teslameter with Probe

This economical digital teslameter will allow students to incorporate quantitative measurements into their magnetism experiments. The unit includes a Hall sensor probe for measuring axial and tangential magnetic fields up to 200 mT. The probe also serves as a ruler as it includes a metric scale. There are two measuring ranges, 0-±20 mT and 0-±200 mT. The teslameter can be calibrated by the user. In addition to having a digital display, the unit outputs a voltage proportional to the magnetic field which can be measured with a data logger, XY-recorder or analog multimeter.

Measurement ranges: 0 – ±20 mT, 0 – ±200 mT

Resolution: 0.01 mT, 0.1 mT

Digital Display: 3½ digit LCD

Height of digits: 13 mm

Input: BNC socket

Output: 4 mm safety sockets

Dimensions of unit: 205 x 230 x 85 mm³

Dimensions of probe: 360 x 15 x 25 mm³

1003313 \$395.00

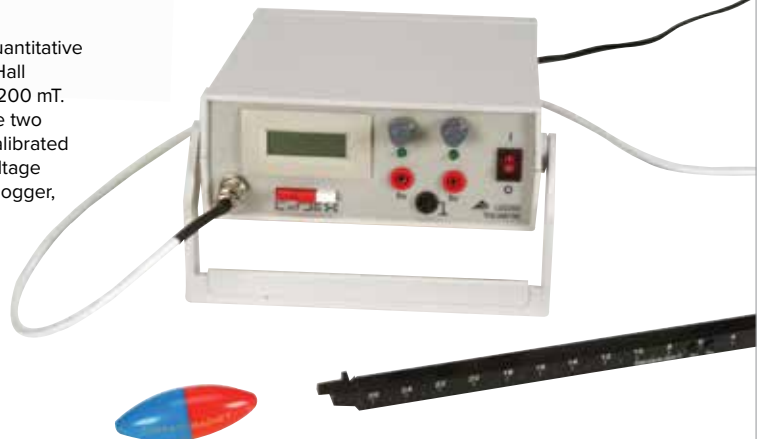

Resistance Measurement Bridge

Used to investigate the dependency of electrical resistance on conductor length, conductor crosssection and material. 6 wires are laid out side by side on a block of wood and both ends connect to 4-mm sockets.

Wire lengths: 1,000 mm

Dimensions: 1,085 x 70 x 55 mm (LxWxH)

Weight: approx. 1.5 kg

1009949 \$278.00

Additionally Required:

LCR Meter

3004095 \$257.00





Magnetic Equipment Set

A selection of various magnets for introducing the subject of magnetism; complete with a specially molded storage tray.

Includes:

- 3 AlNiCo round magnets: 12 mm, 19 mm, 24 mm Ø
- 1 AlNiCo horseshoe magnet, 25 mm long
- 2 Chromium-steel bar magnets, 100 mm x 6 mm Ø
- 1 Natural magnet
- 4 Colored magnetic foils, 50x50 mm
- 2 Bar magnets in a protective plastic case, 80 mm long
- 2 Drawing compasses, 19 mm Ø
- 2 Drawing compasses, 16 mm Ø
- 5 Iron ring magnets, 25 mm Ø
- 5 Iron magnets, 19 x 19 x 5 mm
- 1 Chromium-steel horseshoe magnet, 100 mm long

1003089 \$101.00

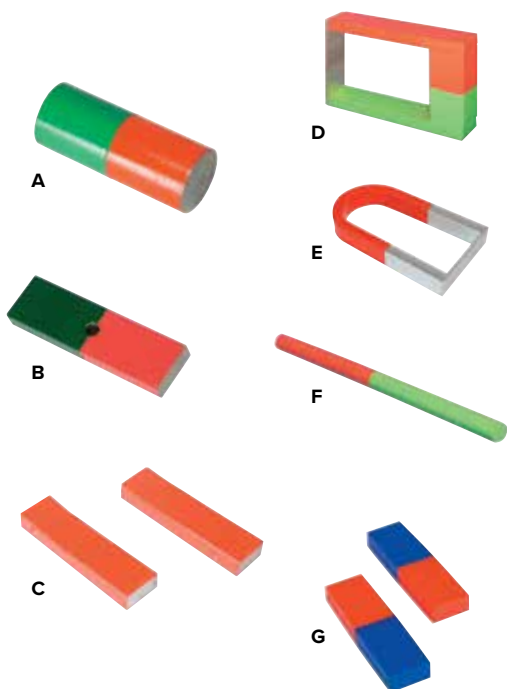

A. Cylindrical Bar Magnet 50 x 20

Round bar magnet with poles marked red and green.

Dimensions: approx. 50 x 20 mm dia.

1003556 \$27.00

B. Bar Magnet, Alnico, 70 mm

Alnico bar magnet with poles marked red and green.

Dimensions: approx. 70 x 20 x 8 mm³

Weight: approx. 80 g

1003554 \$35.00

C. Pair of Bar Magnets, AlNiCo

Pair of AlNiCo bar magnets, red, with north pole marked. Including two iron yokes.

Dimensions: 60 x 15 x 5 mm

1003086 \$23.00

D. Large Horseshoe Magnet with Yoke

Poles colored red/green.

Length: 130 mm

Pole spacing: 60 mm

Pull-off force of yoke: 250 N

1003114 \$146.00

E. Horseshoe Magnet with Yoke

Chromium-steel U-magnet with yoke, red and silver colored poles.

Dimensions: 140 x 20 x 10 mm

1003088 \$36.00

F. Round Magnet, AlNiCo

Round magnet made of AlNiCo. Poles colored red/green.

Length: 200 mm

Diameter: 12 mm

1003112 \$52.00

G. Pair of Bar Magnets, 80 mm

Pair of bar magnets in a protective plastic case; poles identified in red and blue.

Dimensions: 80 x 22 x 10 mm

1003085 \$11.00

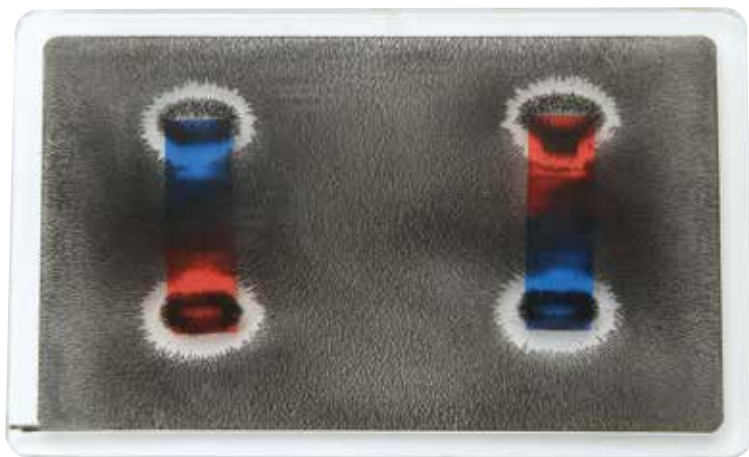

Demonstration of Magnetic Field Lines, transparent

When used in conjunction with an overhead projector, this device demonstrates the presence of magnetic field lines. The transparent plastic vessel is filled with a liquid containing magnetic powder. Magnets and an experiment manual are included.

1003092 \$111.00



H. Appliance for the Introduction of Lenz's Law

Used for qualitative investigation of Lenz's law. One closed and one open conductor loop, with point bearing on base.

Length: 195 mm

Height: 110 mm

1009959 \$42.00

I. Magnetic Needle

Mounted on base with pivot point.

Length: 80 mm

Height: 110 mm

1000674 \$37.00



Magnetic Field Indicator

Bar magnet, with poles identified by color and free to turn in space, for three-dimensional mapping of magnetic fields. Pivots on agate gimbal bearings allow the small bar magnet free rotation in space. Magnet poles are color-coded. Handle and cardanic suspension made of plastic to alleviate any adverse effects on magnetic field.

Magnet: approx. 25 x 3 x 3 mm³

Handle length: approx. 95 mm

1003555 \$76.00



Suspended Magnet

For demonstrating repulsion forces between magnets. Two ring magnets facing each other with identical poles are slid on a rod.

Base: 100 mm Ø

Rod: 100 mm x 30 mm Ø

Weight: 410 g

1000943 \$64.00

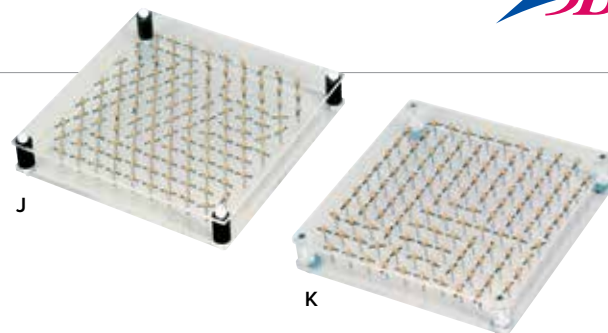

Magnetic Model

To demonstrate the behavior of molecular magnets in ferromagnetic materials, 117 freely rotating magnetic needles are mounted between two acrylic glass discs.

Length of the molecular magnets: approx. 11 mm

Measurements: 1 x 50 x 150 mm

J. Hexagonal Magnet Model 1002975 \$340.00

K. Cubic Magnet Model 1002976 \$340.00

Additionally Required:

Round Magnet 1003112 \$52.00

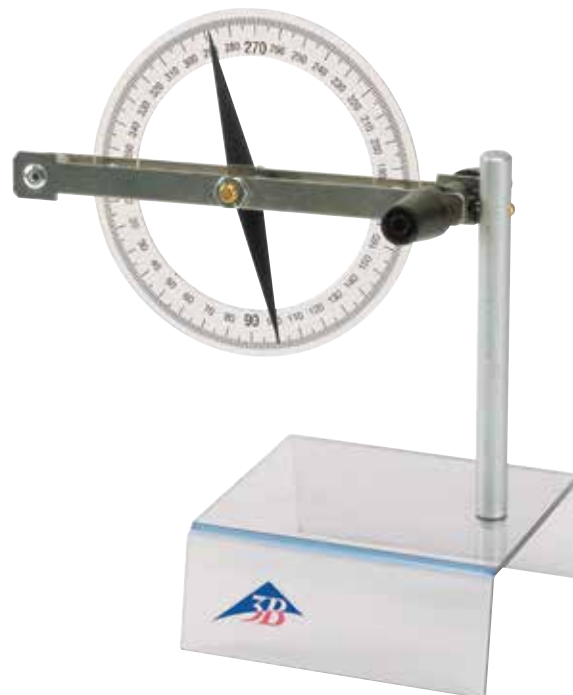

Magnetic Field Incliner

Accurate and easy to use, our magnetic field inclinometer is designed for determining the direction, in horizontal and vertical increments, of the Earth's magnetic field and to demonstrate the magnetic field of a current carrying conductor. The instrument has an aluminum conductor loop with 4-mm safety sockets. A magnetic needle with a pointed axle rotates on bearings above a full circle in transparent material with an angle scale rotating about the horizontal axis and mounted on acrylic base.

Diameter of circle: 110 mm

Length of magnetic needle: 100 mm

Strap length: 150 mm

Terminal: Via 4 mm safety sockets

Base dimensions: 100 x 90 mm

Height: 185 mm

1003192 \$114.00

Globe with Bar Magnet

Used to demonstrate the earth's magnetic field lines. A bar magnet is located at the polar axis. A compass or magnetic field sensor is then positioned at any given location on the globe's surface so that it aligns with the magnetic field parallel to the longitudinal lines. The inclination can also be determined using the magnetic field sensor.

Diameter: 150 mm

Weight: approx. 150 g

1013123 \$98.00





Field & Induction Coils

Used for measuring the intensity of magnetic fields as a function of the current and the number of turns per unit length (with U8496175), to demonstrate that the field intensity is independent of the coil area, and for quantitative induction experiments and electric resonant circuits; only for extra-low voltages. The bobbins are made of plexiglass, thus offering a view into and through the coils.

Number of turns: 90
 Coil length: 49 cm
 Current: Max. 10 A, short-term 20 A
 Connection: Via 4 mm sockets

Field Coil, 100 mm 1000591 \$241.00
Field Coil, 120 mm 1000592 \$338.00



Variable Inductance Coil

This experiment measures inductance and self-inductance of a current-carrying coil and how they change depending on the insertion of an iron core. It is also good for investigating how AC circuits work and what effect coils produce in those situations.

Number of windings: 3000
 Max. permissible voltage: 30 V AC, 60 V DC
 Max. permissible current: 2 A
 Inductance: Continuously adjustable from 0.15 to 1.4 H, for current of approximately 1 A

Resistance: 12.5 Ω
 Connections: Via 4 mm safety plugs
 Dimensions: 265 x 145 x 130 mm
 Weight: 6.2 kg

1003194 \$516.00



Equipment Kit "Hysteresis Curve"

Apparatus for recording the magnetic flux density as a function of the magnetic field strength in different samples.

Dimensions of the iron samples: approx. 140 mm x 10 mm diam.
 Number of turns: 850
 Internal resistance: 3.2 W
 Inductance without core: 3.2 mH
 Dimensions: approx. 200 x 145 x 65 mm³
 Total weight: approx. 470 g

1018889 \$288.00

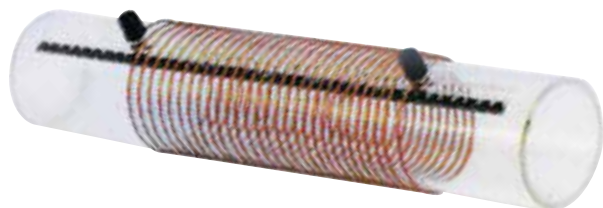

Coil with Variable Number of Turns Per Unit Length

For investigating the intensity of magnetic fields as a function of the number of turns per unit length.

Number of turns: 30
 Coil diameter: 100 mm
 Coil length: 49 cm
 Current: Max. 10 A, short-term 20 A
 Connection: Via 4 mm sockets

1000965 \$318.00

Acrylic Stand for Coils

1000964 \$65.00



Set of 3 Induction Coils
 Connection: 4 mm sockets
1000590 \$367.00



Magnetizing and Demagnetizing Coil

This solenoid allows you to magnetize and demagnetize ordinary magnets or iron bars in addition to conducting inductance experiments. The rugged unit consists of insulated copper winding mounted on a base with 4mm sockets and a switch.

Windings: 1000
 Coil length: 250 mm
 Coil radius: 35 mm internal
 Operating Voltage: Max. 12 V DC or 12 V AC
 Dimensions: 305 x 200 x 100 mm³
 Mass: 2 kg
1003237 \$210.00

A. Induction Apparatus

For the demonstration and investigation of an induction voltage, which is caused by a frame coil moving on a magnetic plate. By varying the speed and the frame coil's number of turns the law of induction can be verified quantitatively in an experiment. Using a conveyor cable the frame coil is moved up and down the magnetic plate at a constant speed by means of a motor. This generates a constant induction voltage. The direction of the movement can be reversed using a changeover switch and the speed can be varied by means of the voltage. Furthermore the rolling motion of a current-carrying conductor can be demonstrated inside the field of the magnetic plate. The transparent design of the magnetic plate and coils means that they can be demonstrated on the overhead projector. An unfoldable support permits inclined setup.

- Experiment Topics:**
- Magnetic flux lines of bar and horseshoe magnets
 - Magnetic screening
 - Magnetic induction
 - Lines of force of electromagnetic fields of straight conductors
 - Conductors that form a ring
 - Cylindrical coils and electromagnets

Operating voltage: 2 - 12 V DC
 Frame coil (LxB): 185 x 125 mm
 Total dimensions: 585 x 200 x 55 mm (LxWxH)
 Weight: 3 kg

Includes:
 Induction apparatus with retractable magnetic plate, frame coil, rolling conductor loop (pictured above).

1000968 \$1,133.00

Additionally Required:

B. DC Power Supply 1003311 \$348.00
C. Multimeter 3004188 \$49.99

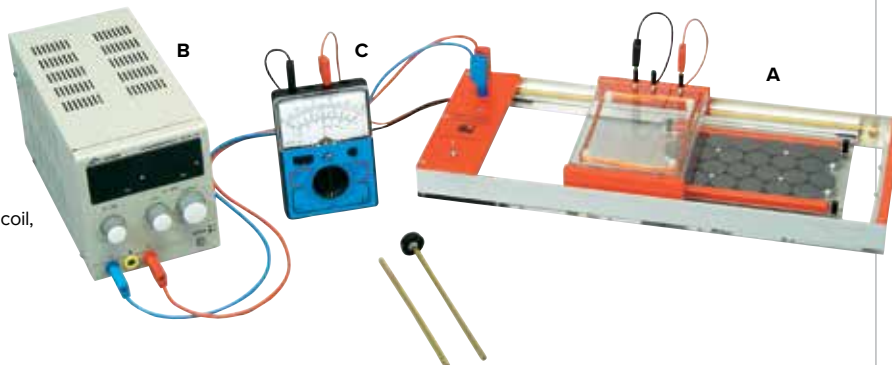

| Lenght | Coil1 | Coil2 | Coil3 |
|------------------|--|------------|---------|
| Number of turns | 300 with two taps at the 100th and 200th turns | 300 | 300 |
| Coil crossection | 50 x 50 mm | 50 x 30 mm | 50 x 20 |
| Coil length | 170 mm | 170 mm | 170 mm |

Apparatus for Displaying Magnetic Fields

Equipment set for demonstration experiments designed to make visible the magnetic field distribution of permanent magnets and current carrying conductors. Also compatible for use with a daylight projector. The acrylic glass boxes containing iron filings are equipped with a pouring lip so that the used fillings can easily be refilled into the storage bottle.

Acrylic glass boxes: approx. 185 x 125 x 40 mm
 Storage tray: approx. 430 x 380 x 25 mm
 Weight: approx. 1.5 kg
1000925 \$508.00

Additionally Required:

High Current Power Supply (below) 1002771 \$1,228.00
HD Camera 3003298 \$329.00

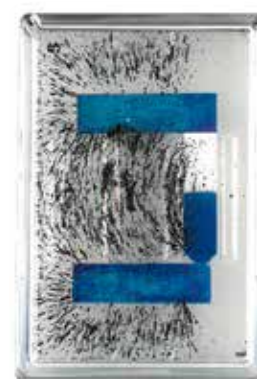

A



B

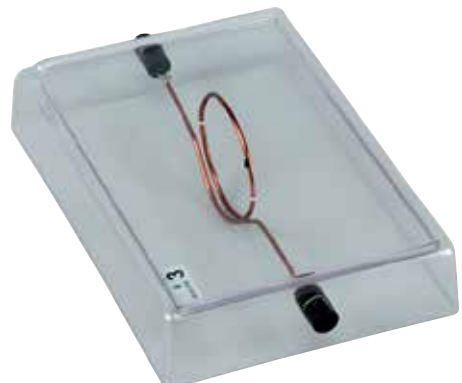

C



D



Conductor on Acrylic Base Plate

When combined with iron filings or iron granules, the magnetic field associated with straight or looped conductors can be displayed brilliantly on an overhead projector. Contains two 4 mm sockets for the current supply.

Base measurements: 185 x 150 x 30 mm
 Number of turns: 9
 Diameter of turns: 45 mm
 Length of turns: 75 mm
 Measurements: 185 x 150 x 30 mm

A. Straight Conductor
 1000926 \$76.00

B. Loop Conductor
 1000927 \$79.00

C. Coil Conductor
 1000928 \$89.00

D. Iron Filings
 1000580 \$30.00



Complete Fine Beam Tube System

This system is used to determine an electron's specific charge and investigate the deflection of electron beams in a uniform magnetic field. Includes plug-in power supply and holder for fibre-optic cable.

Dimensions: 133 x 120 x 60 mm³
 Weight: 950 g

The complete fine-beam tube system consists of the following parts:

Fine Beam Tube T
 Operating Unit for Fine-Beam Tube

Spare tube for Fine Beam Tube T: 1008505
1013843 \$ 2,645.00

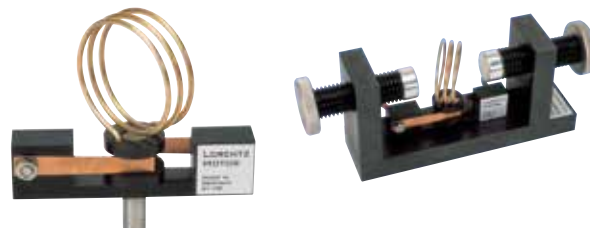

Lorentz Motor

Demonstrate Lorentz force - suspend a current-carrying object between two magnets. Comprising a motor armature without an iron core, this device is intended for installation inside the permanent magnet with adjustable pole spacing (U10370). The coil is rotated purely by the Lorentz force, its direction of rotation depending on the direction of the current.

- Can be assembled in a matter of seconds
- Can be deployed directly in a permanent magnet with adjustable pole distance
- No iron core – rotation of the coil solely effected by Lorentz force

Includes:

1 Motor armature with contact springs
1002662 \$141.00

Additionally Required:

Permanent Magnet w/adjustable pole spacing 1002660 \$419.00
DC Power Supply 1003311 \$348.00



Electromagnetic Test Equipment

Consists of a stable, firm, anodized-aluminum tripod with pre-defined magnet positions and accessory mountings. The deflection of the conductor swing can be adjusted in steps of 0, 15, 30 and 45 mm for current balance experiments.

Includes:

- 1 Aluminum tripod, anodized
- 1 Conductor swing with 4-mm safety jacks
- 2 Waltenhofen pendulums (solid and slotted)
- 1 Glass rod and polyester thread with hook
- 1 Aluminum rod and polyester thread with hook
- 1 Knurled screw

1002661 \$608.00

Additionally Required:

Permanent Magnet 1002660 \$419.00
with adjustable pole spacing
DC Power Supply 1003311 \$348.00



Pair of Helmholtz Coils

This device is used to produce a homogeneous magnetic field. It is intended for experiments on induction and beat in conjunction with the rotary frame and flat coil (U8481510) and for determination of e/m in conjunction with the electron-beam tube (U8481420). The coils can be switched in parallel or in series. A spring clip on the top crossbar is used to mount the Hall sensor during measurements of the magnetic field.

Coil diameter: 295 mm
 Coil spacing: 150 mm
 Number of turns per coil: 124
 Copper wire thickness: 1.5 mm
 DC resistance: 1.2 Ω each
 Maximum coil current: 5 A
 Maximum coil voltage: 6 V
 Maximum flux density at 5 A: 3.7 mT
 Weight: approx. 4.1 kg

1000906 \$777.00

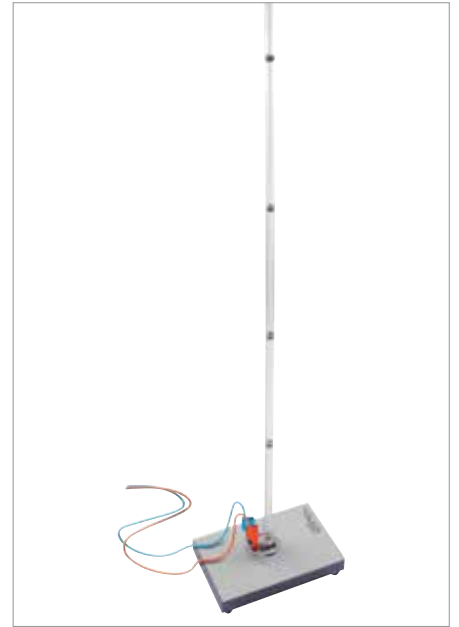

Tube with Six Induction Coils

Plastic tube with six identical induction coils connected in series. When the bar magnet provided is allowed to fall through the tube, a voltage is induced in each of the coils in turn. As the velocity of the magnet increases with time during its fall, the amplitudes of the voltage peaks also increase, and their width decreases. The area under each voltage peak remains constant.

Coil width: 10 mm
 Dis. between coils: 190 mm
 Dimensions: 1500 mm x 20 mm dia.
 Weight: approx. 500 g

1001005 \$232.00

Additionally Required:

Digital Oscilloscope
3001446 \$1,007.00

Helmholtz Coils on Base Plate

Used to generate homogenous magnetic fields and to determine the Helmholtz configuration. The apparatus comprises a pair of coils arranged parallel to each other mounted on a robust metal base plate with a holder for a magnetic field meter to measure the magnetic field. One coil and its holder are moveable. The coils can be connected in parallel or series. There are two scales printed on the base plate to allow coil separation to be read off and to determine how far the measurement probe's position deviates laterally from the coil axis.

Number of turns: 100 each
 Average coil diameter: 125 mm
 Coil width: 33 mm
 Terminals: Via 4 mm safety sockets
 Max. permissible current: 5 A
 Max. coil separation: 240 mm
 Scale division: mm
 Base plate: 400 x 200 mm

1003193 \$455.00

Additionally Required:
High Voltage Power Supply 1003309 \$658.00

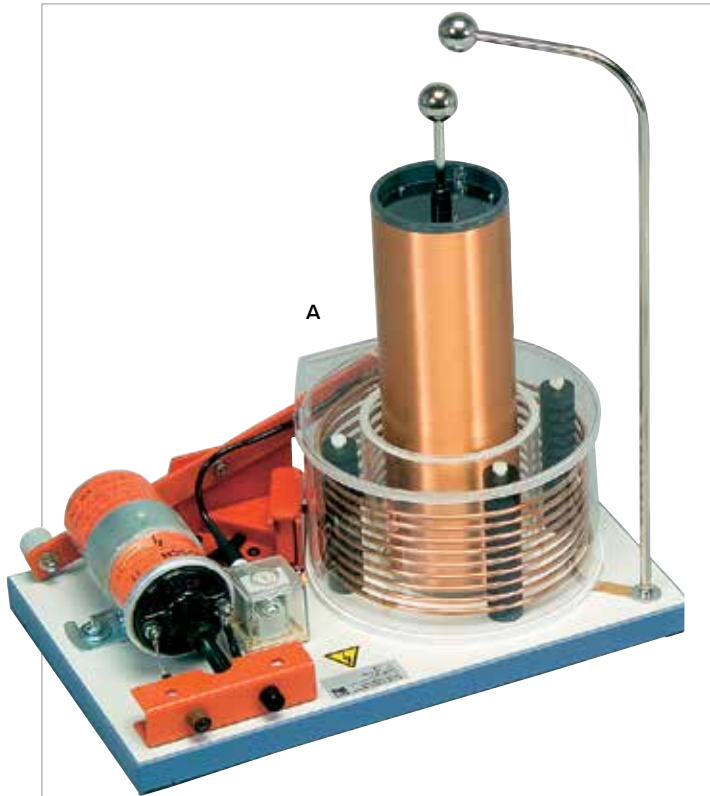

A

A. Tesla Transformer

Classic Tesla transformer for the generation of a safe high frequency high voltage starting from approx. 100 kV. The well-conceived, open configuration of all components facilitates demonstration of both design and function. The apparatus is rendered shock proof on account of its extra low voltage operation.

No. of turns in the primary coil: 2 – 10
 No. of turns in the secondary coils: 1150
 Primary voltage: 20 V AC
 Secondary voltage: >100 kV
 Transformer: approx. 330 x 200 x 120 mm
 Secondary coils: approx. 240 x 75 mm dia.
 Weight: approx. 3 kg

Contents:

- 1 Tesla transformer, basic apparatus
- 1 Hand coil
- 1 Secondary coil
- 1 Spherical electrode, short
- 1 Spherical electrode, long
- 1 Needle electrode with spray wheel
- 1 Fluorescent tube
- 1 Reflector

1000966 \$1,108.00

B. Additional Coil for Tesla Transformer

Dimensions: approx. 240 x 75 mm dia.
1000967 \$181.00



B

Transformer Coils

Impact resistant plastic covered coils, safe to touch, for assembling a transformer in conjunction with the transformer core (U8498112).

Maximum voltage: 50 V
 Terminals: 4 mm
 Opening for iron cores: 20 mm²

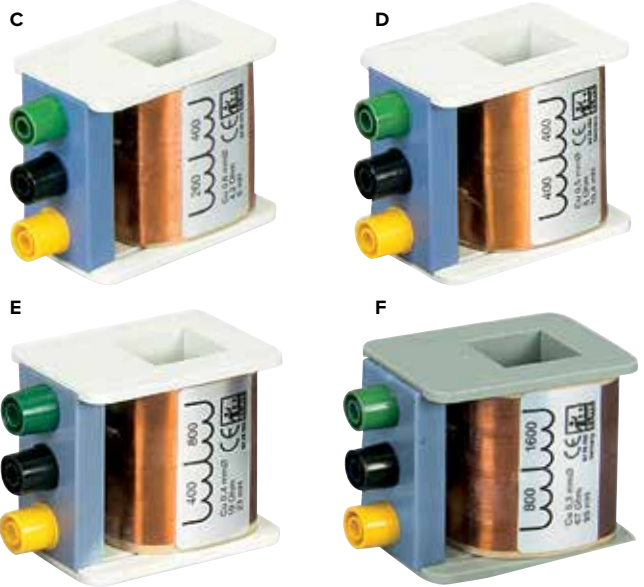

| Item Number | Inductance | Turns | Taps | Price |
|-------------------|------------|-------|---------------|----------------|
| C. 1001000 | 6 mH | 600 | 200/400/600 | \$38.00 |
| D. 1001001 | 10 mH | 800 | 400/800 | \$38.00 |
| E. 1001002 | 25 mH | 1200 | 400/800 | \$44.00 |
| F. 1001003 | 100 mH | 2400 | 800/1600/2400 | \$44.00 |

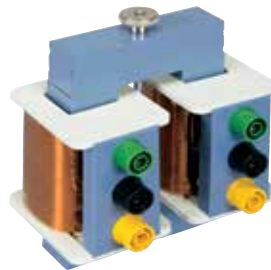

Transformer Core

U-core with removable yoke made of high quality transformer laminate.

Core cross section: approx. 20 mm²
 U-core: approx. 70 mm²
 Length of yoke: approx. 70 mm²

1001004 \$162.00

High Current Coil

Secondary coil for transformer core S (U8498112) for generating high current output.

No. of windings: 22
1000999 \$67.00

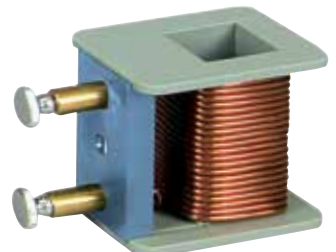

Experiment Topics:

- Voltage measurement of galvanic elements
- Standard potentials of different pairs of metals/metal cations
- Standard potentials of different pairs of non-metals/non-metal cations
- Voltage measurement of concentration chains
- Electrochemical corrosion of iron
- Measurement of pH values of different electrolyte solutions
- Daniell cell
- Leclanché cell
- Fuel cells

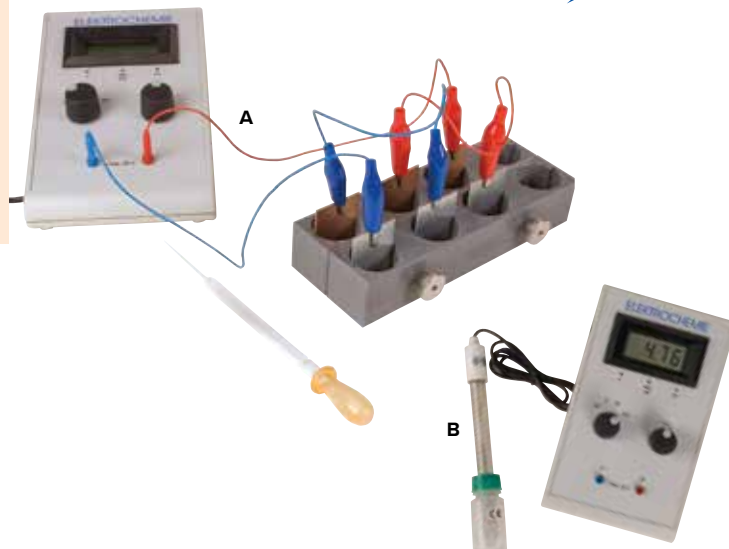

A. Electrochemistry Kit

A complete equipment set for basic experiments in electrochemistry. Includes a handy measurement device with an LCD display for pH values and practically zero-current measurement of voltages, as well as a pH combined electrode with a highly flexible cable. Enclosed in a robust console housing with labeling on a resistant SKF inscription foil with a scratch-proof coating.

1002719 \$825.00

B. pH Combined Electrode

pH combined electrode with shaft made of plastic and a BNC plug.

Length of cable: 1 m

Dimensions: 120 x 12 mm Ø

1002720 \$67.00

| Item Number | Description | Specifications | Price |
|-------------|-----------------------|--|----------------|
| 3004211 | pH Buffer Pouches | 6 ea. of pH4, pH7 & pH10 | \$30.99 |
| 3001325 | Blue Litmus | pH 4.3 – 6.8, 100/vial | \$1.50 |
| U49564 | Red Litmus | pH 6.8 – 8.1, 100/vial | \$1.50 |
| 3001327 | Wide Range pH | Determines pH values 1 – 14, 100/vial | \$1.50 |
| 3007595 | Teacher Demo Wide | Wide Range in 1" x 9.5", 100/vial | \$6.50 |
| 3001324 | Acid, Base or Neutral | Determines graduated pH ranges, 100/vial | \$1.69 |



Oyster Series pH/mV/Temp meter

Includes one pH probe and 2 buffer solutions.

3004212 \$219.99



Leclanché Cell

This model of a dry battery was invented by the French chemist Georges Leclanché in the 1860s. It consists of a cylindrical zinc electrode, a rod shaped carbon electrode, a clay vessel and a battery glass. Filled with cell electrolyte, the Leclanché cell supplies a voltage of approximately 1.5 volts. The cell is delivered without a filling.

Connections: via 4 mm jacks

Dimensions: 105 mm high, 65 mm diameter

Suitable fillings:

Copper sulphate solution (CuSO₄) 10% and zinc sulphate solution (ZnSO₄) 10%

1002897 \$128.00



Daniell Cell

Students make a Daniell Cell to study the characteristics of voltaic cells. A copper electrode is immersed in dilute ammonium chloride solution in a porous cup. These, in turn, are immersed in copper sulfate solution containing a zinc electrode, to produce an emf of 1.08 V. The cell includes a battery jar, zinc and copper electrodes and a porous cup. The electrodes have 4-mm sockets. The element is supplied without filling.

Connections: via 4mm jacks

Dimensions: 105 mm high, 65 mm diameter

Suitable fillings:

Copper sulphate solution (CuSO₄) 10% and zinc sulphate solution (ZnSO₄) 10%

1002898 \$111.00

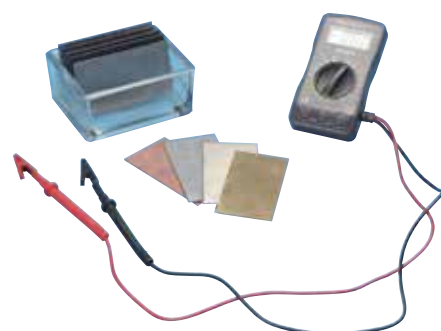

Electrochemistry Set

A simple but effective set to measure electrochemical potential between various metals.

Includes:

- 1 Electrolysis cell
- 1 Copper plate
- 1 Zinc plate
- 1 Iron plate
- 2 Nickel plate
- 1 Aluminum plate
- 2 Carbon plate
- 1 Digital Multimeter
- 2 Lead wires with alligator clips

1002711 \$137.00



Dismountable Transformer Experiment topics:

- Voltage transformation
- Transformer under load
- Current transformation
- Autotransformer
- Leakage field experiment

Applications:

- Induction oven
- Point welding
- Fusing experiments

Coils for the Dismountable Transformer:

- Coils made of shock-proof plastic
- Contact-safe with safety sockets
- Technical data printed on coils: number of turns, maximum continuous current, effective resistance and inductance
- Rated continuous current may be exceeded briefly by several factors

Connections: via 4-mm safety sockets
 Dimensions: 120 x 90 x 70 mm
 Opening for iron cores: 42 mm²

| Item Number | Turns | Taps | Resistance | Max. Current | Inductance | Price |
|-------------|--------|---------------|------------|--------------|------------|----------|
| 1000985 | 72 | 6/30/54/66/72 | 0.1 Ω | 12 A | 0.23 mH | \$258.00 |
| 1000984 | 6 | N/A | 3 mΩ | 60 A | 0.25 mH | \$165.00 |
| 1000990 | 6000 | 2000/6000 | 350 Ω | 0.2 A | 1.5 H | \$249.00 |
| 1000989 | 1200 | 400/1200 | 12 Ω | 1.2 A | 60 mH | \$140.00 |
| 1000988 | 600 | 200/600 | 3 Ω | 2.2 A | 15 mH | \$140.00 |
| 1000991 | 24,000 | N/A | 10 kΩ | 0.02 A | 28 H | \$585.00 |

Attention: Coils can carry both low or high voltage as secondary coils. Do not use these in student experiments.

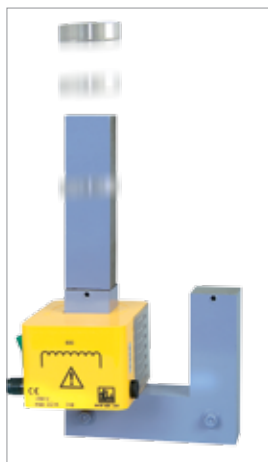
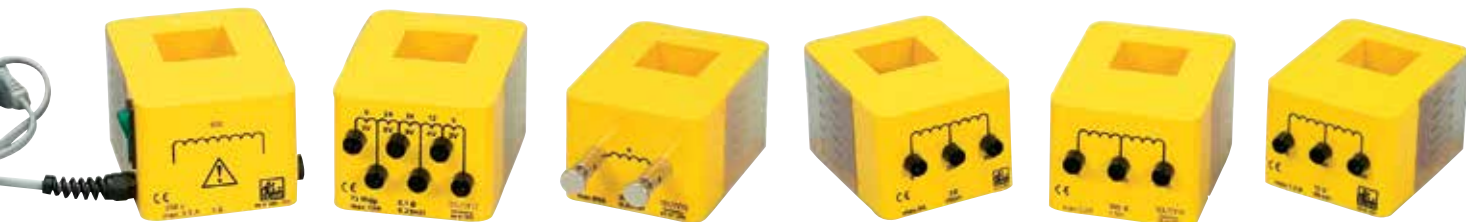

Metal Ring

For performing Thomson's ring experiments in conjunction with the mains coil U8497430-115 and the transformer core with yoke U8497180. The mains coil is arranged in the U-core in such a manner that the yoke stands upright on it. The metal ring is placed above it. When the mains coil is switched on the ring jumps into the air.

Ring: 55 mm Øinternal

1000992 \$18.00

Additionally Required:

Transformer Core 1000976 \$364.00



Experiment Topics:

- Effect of force acting on a current-carrying conductor in a magnetic field
- Measurement of the magnetic flux density
- Effect of induction acting on a single conductor in the magnetic field
- Force between two parallel linear conductors
- Definition of ampere



Transformer Core with Yoke

Heavy U-shaped core for the generation of powerful magnetic flux. Made of high-quality transformer sheet metal, laminated, with two clamps to attach the pole shoes U8497200 or the yoke.

U-core: 150 x 130 x 40 mm

Yoke: 150 x 40 x 40 mm

Weight: approx. 6 kg

1000976 \$364.00

Pair of Pole Shoes, drilled

Defined air gap e.g. for electromagnets, altenhofen's pendulum as well as for investigating paramagnetic and diamagnetic samples.

Each designed with a plane and a conical end.

Pole shoe: 40 mm²

Weight: 1.7 kg

1000978 \$82.00



Fusion Ring

Circular aluminum channel with insulated handle used to explain the principle of induction melting. Use as a secondary coil in conjunction with a mains coil of 600 turns as primary coil U8497420.

Suitable melting material: Wood's Alloy

Internal diameter: 57 mm

Weight: approx.: 80 g

1000980 \$44.00

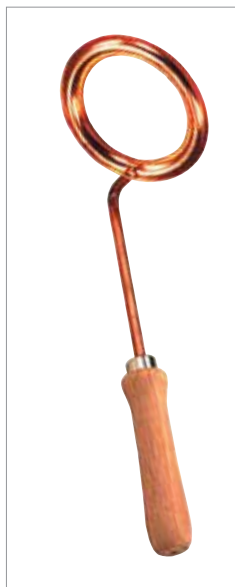

Additionally Required:

Mains coil of 600 turns



Coil with 5 Turns

Secondary coil for creating high currents for spot welding of sheet metal of up to 2 mm thickness.

Turns: 5

Internal diameter: 57 mm

Weight: approx. 650 g

1000981 \$160.00

Set of Metal Strips

Five metal strips used to demonstrate spot welding techniques in conjunction with a Coil with 5 turns, U8497320.

Dimensions: 300 x 15 x 0.4 mm

1000982 \$11.00



Waltenhofen's Pendulum

For the demonstration of the effects of eddy currents and braking.

A pendulum object composed of a solid steel plate swings back and forth between the poles of an electromagnet with the power switched off. When the magnet is switched on, the pendulum motion of the object comes to an almost immediate halt. If the plate contains slots more time elapses before the plate stops moving, i.e. the braking effect is severely reduced. The equipment set consists of a pendulum rod

and four aluminium pendulum plates with various shapes: rectangle, rectangle with slits, circular disk, ring and ring with slits.

Rectangular: 100 x 60 mm

Ring: 30 mm Ø interior, 60 mm Ø exterior

1000993 \$115.00

Additionally Required:

Pair of Pole Pieces **1000978 \$82.00**

Transformer Core w/Yoke **1000976 \$364.00**

(2) Coils w/1200 Turns **1000989 \$140.00**

DC-Power Supply **1003311 \$348.00**



HEAT & THERMODYNAMICS



A. Critical Point Apparatus

Precision equipment for investigating compressibility and liquefaction of a gas. Measurements allow the critical point for the gas to be determined as well as the recording of isotherms for an adiabatic p-V diagram (Clapeyron diagram). The gas used for testing is SF₆ – sulphur hexafluoride. This has a critical temperature of 319 K (46° C) and a critical pressure of 3.76 MPa (37.6 bar). It allows the experiment set-up to be simple, robust and understandable so that both qualitative investigations and precise measurements can be made. SF₆ is completely non-hazardous and can be used without reservation in lessons and labs. The pressure is applied by a hydraulic system using castor oil of medicinally authorized quality.

- No mercury needed! Traditional equipment used to examine the critical point are filled with mercury which is harmful both to nerves and kidneys
- Using two scales (one stationary and one co-rotational) any change in volume can be read off with an accuracy of 1/1000 of the maximum volume (15.7 ml)
- Class 1.0 manometer (max. 1% deviation from the end value of the scale) with 160 mm diameter and a display gauge up to 60 bar
- Drill hole with 6 mm diameter for commercially available thermometer or temperature sensor
- The theoretically long-life of the measuring cell amounts to 70 bar; while the theoretical bursting pressure point is above 200 bar

Dimensions: Base plate 37 x 20 cm, height 39 cm
Weight: approx. 6.9 kg.

Includes:

- 1 Apparatus for measuring critical point
 - 1 Cold light
 - 1 Safety valve
 - 1 Oil-filling attachment
- 1002670 \$6,528.00**

B. Immersion/Circulation Thermostat

This immersion/circulation thermostat has a closed bath for thermostatic control of water tanks or external apparatus with non-flammable liquids at temperatures of up to 100° C. The fully electronic continuous controller and powerful circulation pump with a rotatable pump housing ensure ideal bath circulation and, therefore, a high degree of temperature constancy. The rotary knob is used for analog setting of setpoint values. Actual values are indicated by a glass thermometer. Clearly visible indicator lights for heating functions and errors increase operational safety.

Includes a connection for a continuous cooler, a cooling coil which makes use of tap water as the coolant, a thermometer with a display range of 0 - 100°C and a plug.

| | |
|------------------------------|-----------------------|
| Operating-temperature range: | 25°C to 100°C |
| Temperature constancy: | ± 0.05°C |
| Heating power: | 1.5 kW |
| Pump pressure: | max. 0.15 bar |
| Delivery rate: | max. 8 l/min |
| Bath volume: | 2.5 l to 3.5 l |
| Bath area / depth: | 135 x 105 mm / 150 mm |
| Mains connection: | 115 V; 50/60 Hz |

1008653 \$1,884.00

Additionally Required:

Silicone Tubing x2 1002622 \$10.00

Additionally Required:

| | | |
|---|----------------|-------------------------|
| Immersion/Circulation Thermostat | 1008653 | \$1,884.00 |
| Differential thermometer | 3004200 | \$249.99 |
| 1L Sulfur Hexafluoride | 3003100 | Call for Pricing |
| Regulator for U42710 | 3003099 | Call for Pricing |

Castor oil

Extra shipping applies. Please contact us at **1.866.448.5847** for more details.

Boyle-Mariotte Apparatus

Apparatus for determining experimentally the relationship between gas volume and pressure at constant temperature (Boyle's law). The working cylinder is made of transparent acrylic and has a moving piston, scale and manometer. Along with a valve to let in gas or release it. The movement of the piston is achieved with the help of a threaded connecting rod turned by means of a manual crank. In this way, pressure both above and below atmospheric can be generated. For safety reasons, the working cylinder is enclosed in another protective transparent acrylic cylinder.

Length: 300 mm
 Internal diameter: 40 mm
 Piston: 30 mm x 40 mm diameter
 Piston sealing: 2 ring gaskets
 Manometer diameter: 100 mm
 Permitted pressure: max. 4 bar
1017366 \$584.00



➤ Free manuals and experiment guides available at 3bscientific.com!

Ball and Ring Apparatus
 An excellent device for demonstrating thermal expansion of solid bodies. Brass ball and ring with wooden handles. Length: 10"
3001227 \$10.25

Student Thermal Expansion Apparatus
 Used for measuring the thermal expansion of iron, copper and glass tubes. Consists of a base strip with a clamping spring, pointer, scale and hose nipple. Includes three sample tubes made of iron, copper and glass.
 Magnification factor: 50
 Tube Length: approx. 63 mm
 Total dimensions: 53 x 6 x 24 cm
 Weight: 0.6 kg
1002978 \$201.00



Dilatometer Advanced Thermal Expansion Apparatus

Used for simultaneous measurement and comparison of the thermal expansion coefficients of rod-shaped bodies. Linear expansion of the rods is displayed on a mirror scale via three rollers with differently colored pointers. Swift and uniform heating is achieved by the application of the steam generator U8624650-115.

Rods: Brass, aluminum, glass
 Dimensions (LxWxH): 830 x 80 x 70 mm
 Weight: approx. 1.2 kg
 Plate diameter: 90 mm
 Contents of the vessel: 250 ml
 Power consumption: 550 W
1000830 \$343.00

Additionally Required:
1006769 \$290.00



Deluxe Ball with Ring

An arrangement for demonstrating the expansion of solids on heating. After heating in a burner flame, the ball no longer fits through the bore in the bracket. Steel ball with chain and handle.

Dimensions of the bracket in mm: 40 x 50 x 40 mm
 Diameter of ball: 22 mm
 Length of handle with shaft: 225 mm
 Weight: approx. 175 g
1000831 \$51.00



Calorimeter with Heating Coil, Pluggable, 1200 ml

Calorimeter for determining specific heat capacities, conversion energies of materials, mixing temperatures as well as measurement of electrical equivalents of heat. Consists of a double-walled, heat-insulating plastic container with an insulating vessel inside made of reflecting glass, with heating coil and stirrer. Also includes a lid with an opening for a thermometer and two 4 mm plugs for connecting the power supply for the heating coil. If necessary, the heating coil can be removed from the inside of the lid. Two plastic nets for safe loading of samples are included.

Max. heater voltage: 25 V
 Max. heating power: approx. 160 W
 Contents of insulated container: approx. 1200 ml
 Dimensions: approx. 240 mm x 120 mm diam.
 Weight: approx. 0.8 kg

1000821 \$189.00

Additionally Required:

Tube Thermometer, -10 – +100° C 1003526 \$44.00

Additionally Recommended:

Aluminium Shot, 100 g 1000832 \$9.00
Copper Shot, 200 g 1000833 \$25.00
Glass Shot, 100 g 1000834 \$10.00

DC Power Supply, 0 – 20 V, 0 – 5 A (115 V, 50/60 Hz)

1003311 \$348.00

Calorimeter with Heating Coil

Calorimeter for determining the specific heat capacity of solids and liquids and for measuring the electric heat equivalent. Two mutually insulated aluminum beakers, lid with rubber stopper with boreholes for thermometer and stirrer, with heating coil.

Capacity of insulated container: approx. 150 ml
 Connection: 4 mm sockets
 Electric heater: 6 V / 2 A max.

1000822 \$46.00

Additionally Required:

Tube Thermometer, -10 – +100° C 1003526 \$44.00

Additionally Recommended:

Aluminium Shot, 100 g 1000832 \$9.00
Copper Shot, 200 g 1000833 \$25.00
Glass Shot, 100 g 1000834 \$10.00

DC Power Supply, 0 – 20 V, 0 – 5 A (115 V, 50/60 Hz)

1003311 \$348.00

Did you know our oldest manufacturing plant in Germany has been in operation since 1819? Learn more about us at 3bscientific.com



Pellets

Granules for filling calorimeters.

A. Glass Shot, 100 g 1000834 \$10.00
B. Aluminium Shot, 100 g 1000832 \$9.00
C. Copper Shot, 200 g 1000833 \$25.00

Equivalent of Heat Apparatus

To determine the specific heat capacity of aluminum as well as to verify conservation of energy.

- Solid construction of anodized aluminum with table clamp
- Shaft double ball-bearing mounted
- Built-in counter mechanism
- Heating of the calorimeter through friction or electricity
- Calorimeter with integrated heating element
- Temperature sensor (NTC thermistor) in aluminum sleeve
- Temperature reading via calibration table printed on apparatus
- Snap-in slot in calorimeter bodies for temperature sensor

Includes:

- 1 Basic equivalent of heat apparatus
- 1 Friction cord
- 1 Aluminum calorimeter
- 1 Bucket, 5 l
- 1 Temperature sensor
- 1 Counterweight
- 2 Adapter cables

1002658 \$762.00

Additionally Required:

DC Power Supply 16V, 5A 1003311 \$348.00

Digital Multimeter 3004188 \$49.99

Additionally Recommended:

Copper Calorimeter

Will provide diversity to your Equivalent of Heat Apparatus allowing you to test the properties of copper as well as aluminum. Intuitive installing mechanism for quick and easy experiments.

1002659 \$338.00



Graduated Cylinder, 100 ml

Duran glass, tall form with spout, hexagonal base.

Scale: 100 ml.

Divisions: 1 ml

1002870 \$13.00



Heat-flow Device

For demonstrating heat flows resulting from uneven heating of a liquid. Consists of a right-angled glass tube with a filling neck and GL25 screw connection for pouring in liquids and coloring agents.

Dimensions: approx. 470 x 420 x 30 mm Ø

1002903 \$183.00



Additionally Required:

Duplex Stand Base 1002835 \$62.00

Stainless Steel Rod 1002934 \$15.00

Clamp with Jaw Clamp 1002829 \$22.00

Calorimeter, 200 ml

For determining temperatures of mixtures, specific heat capacities, conversion energies of substances and heat of fusion of ice. Designed for simple experiments for students. Plastic container with styrofoam inlay.

Weight: 80 g

1000823 \$29.00

$$Q = CM\Delta T$$



Additionally Required:

Tube Thermometer, -10 – +100° C 1003526 \$44.00

Additionally Recommended:

Aluminium Shot, 100 g 1000832 \$9.00

Copper Shot, 200 g 1000833 \$25.00

Glass Shot, 100 g 1000834 \$10.00

A. Oscillation Tube

Used for determining adiabatic exponent c_p/c_v of air by Rüchardt's method, used in conjunction with Mariotte flask U14327. Precision glass tube with precisely fitting aluminum cylinder. If the glass tube is placed vertically on a glass flask of 10 L volume and the aluminum cylinder is allowed to slide into the glass tube, it can be made to undergo harmonic oscillations on the air cushion resulting from the enclosed volume of air. c_p/c_v can then be calculated from the period.

Dimensions: 600 mm x 16 mm dia. internal

Aluminum cylinder: 15.2 g

1002895 \$235.00

B. Mariotte Flask

Duran glass flask with discharge opening at base and two rubber stoppers with boreholes.

Volume: 10 L

1002894 \$331.00





> NEW

Leslie Cube with Heater (115 V, 50/60Hz)

Hollow cube made of aluminium for quantitative analysis of thermal radiation from a hot body as a function of temperature and the nature of the surface. Rotatable cube with built-in 150-W lamp and integrated temperature sensor for regulated heating of surfaces to a variable temperature. With holder for thermopile. One side each is plain, matt, white or painted black.

- Heater power: 150 W
- Max. temperature: 120°C
- Resolution: 1°C
- Display: Two rows for actual and set-point temperatures
- Dimensions: 250 x 250 x 220 mm³
- Weight: 1.8 kg approx.

1017729 \$932.00

Additionally required:

Moll Type Thermopile 1000824 \$273.00

Leslie's Cube

A hollow aluminium cube for investigating heat radiation from a hot body as a function of its temperature and surface. With a removable lid for pouring in hot water and 2 openings for inserting a thermometer or thermal sensor and a stirrer. One side each is polished, matte, black and white.

- Dimensions: approx. 100x100x100 mm³
- Weight: approx. 360 g

1000835 \$225.00



Additionally required:

Moll Type Thermopile 1000824 \$273.00



Ice Bomb

Clamping set up for demonstrating volumetric expansion of water on freezing, as well as the tremendous forces which can be exerted in the process. Comprises a steel cylinder with a clamping rib and plastic lid. The set includes 10 cast-iron bolts for breaking in the course of the experiment.

- Diameter for bolt hole: 10 mm
- Dimensions: approx. 40 x 30 x 75 mm
- Weight: approx. 620 g

1000828 \$116.00

Additionally Required:

Cast Iron Bolts, set of 10 bolts 1000827 \$32.00

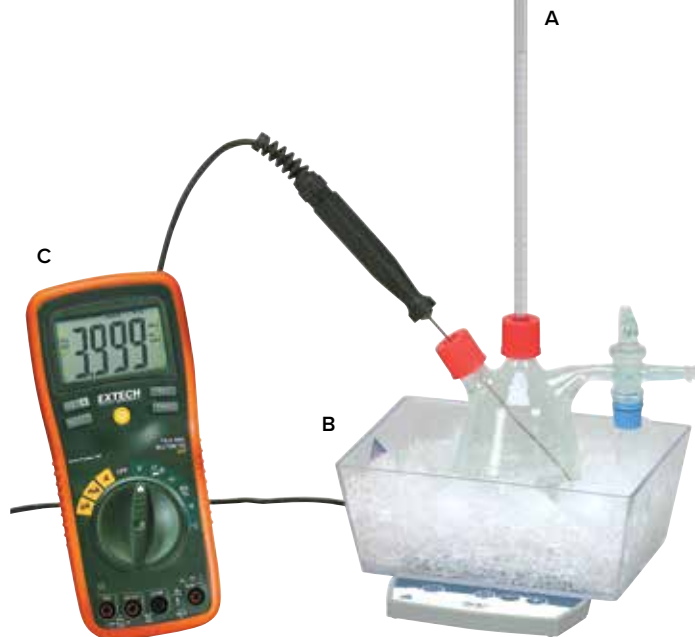

A. Device for Demonstrating the Anomaly of Water

Apparatus for demonstrating the thermal anomaly of water, measuring its thermal expansion and determining its maximum density. Comprises a Duran glass vessel with an inlet tube and two GL screw connections for mounting the riser tube with a mm scale and a temperature sensor or thermometer. Includes stirring rod.

- Volume: 250 ml
- Riser tube: 400 mm
- Capillary: 1.5 mm dia.

1002889 \$141.00

Additionally Required:

- B. Magnetic Stirrer 1002808 \$387.00**
- or Tube Thermometer 1003013 \$35.00**
- C. Digital Thermometer 3004189 \$94.99**
- K-Type NiCr-Ni Immersion Sensor, -65°C – 550°C 1002804 \$87.00**

Moll-type Thermopile

Highly sensitive device for radiation measurement: thermal radiation of a black body, reflection of the long-wave thermal radiation, intensity distribution across the spectrum, Wien's displacement law. Built into a metal casing with polished horn, including two 4-mm connection sockets, mounted on a shaft. The thermopile comprises a surface with a 15 mm diameter and with 17 thermocouples connected to it.

- Sensitivity: approx. 0.28 mV/μW
- Internal resistance: approx. 10 ohm
- Setting duration: 40 s for 95 % of the measured value
- Tripod: 156 mm x 10 mm Ø
- Dimensions: 94 mm x 40 mm Ø
- Weight: approx. 200 g

1000824 \$273.00

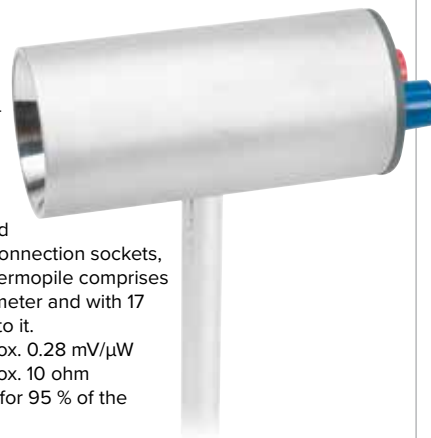

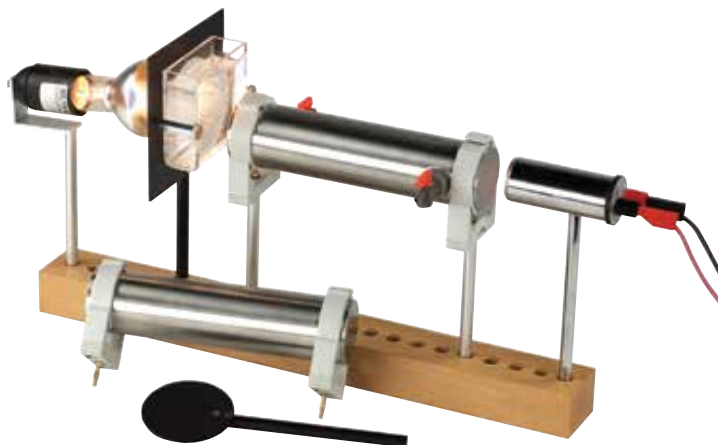

Apparatus for Demonstrating the Greenhouse Effect

Used for demonstrating the effect of greenhouse gases on the absorption of infrared radiation. The experiments are very simple, clearly demonstrated and can be conducted very quickly. The radiation emitted (short-wave infrared and visible light from an incandescent reflector lamp [part 1] or long-wave infrared from a black metal disc [part 2] passes through either air or greenhouse active butane gas in a metal tube. The radiation is partly absorbed and can be registered by the thermopile. Significant differences in the absorption of radiation in part 1 (corresponding to the incident solar radiation on Earth) and part 2 (corresponding to the infrared radiation emitted from Earth) can be demonstrated. The heavy absorption of long-wave infrared radiation by greenhouse-active butane gas impressively demonstrates the mounting rise in temperature of the Earth's atmosphere (greenhouse effect).

Includes:

- Base plate
- Lamp socket with incandescent reflector lamp
- Cell
- Black metal disc
- Plain metal tube
- Metal tube with 2 stopcocks
- 2 shafts
- Silicone hose
- Storage box

1009764 \$358.00

Additionally Required:

Thermopile 1000824 \$273.00

Microvoltmeter 1001015 \$2,000.00

Butane gas

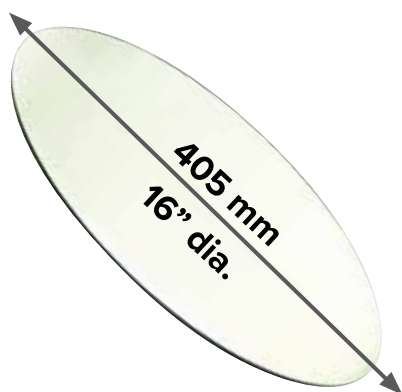

Concave Parabolic Mirror

Used for experiments with sound and thermal radiation, this aluminum, mirror-finished, concave dish is ideal. Easily used for the determination of focus.

Focus: approx. 680 mm

Diameter: 405 mm

3001336 \$59.99

> Create fire from thin air!

Pneumatic Lighter

Device for demonstrating the ignition of diesel. By swiftly pressing down the piston, the compressed air in the transparent tube is heated so strongly that a piece of paper placed at the bottom of the tube very clearly ignites. Similarly, a cotton-wool pad soaked in ether also catches fire.

Compression tube length: approx. 150 mm

1003569 \$106.00



Giant Sized Crookes Radiometer

Our radiometer is twice as tall as the competitor's, allowing for more visible and exciting demonstrations. This classical piece of equipment vividly shows the differential absorption of radiation and expansion of residual gas. The glass globe is 99% evacuated and houses a balanced set of four vanes. Each vane has one black and one white face. When illuminated with an ordinary incandescent bulb, the vanes transform the radiant energy into kinetic energy, as the black sides absorb more heat and thus expand the neighboring gas at a greater rate than the white sides.

Height: 21 cm

Flask diameter: 8 cm

1002882 \$53.00



➤ Also operates as a heat pump or refrigerator

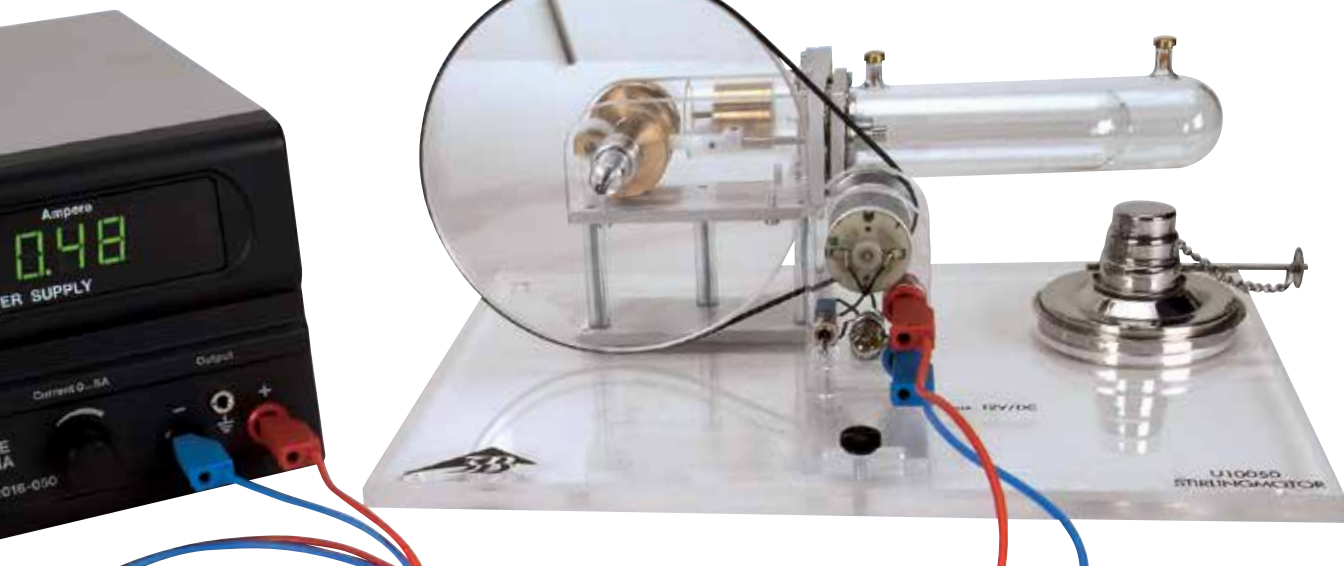

The Stirling Engine is submitted to a load by means of a light source or by a coupled generator. Rotation frequency and temperature changes of the Stirling Engine are observed. Effective mechanical energy and power, as well as effective electrical power, are assessed as a function of rotation frequency. The amount of energy converted to work per cycle can be determined and the efficiency of the Stirling Engine can be estimated. Both the cylinder and the displacement piston are made of heat-resistant glass. The displacement piston provides two connecting pieces for temperature measurements. The power cylinder, flywheel and gearbox cover are made of acrylic glass for clear observation of the individual sequences of motion at all times. The crankshafts have ball bearings and are made of hardened steel. The connecting rods are made of wear-resistant plastic.

The large acrylic glass flywheel has an imprinted marking to allow measurement of revolutions per unit of time using a light barrier. For recording pV-diagrams it is possible to measure the pressure in the power cylinder via a hose connection. A provided string can be fastened to the power piston to measure the stroke in order to determine the volume. The integrated engine-generator unit with a two-stage belt pulley allows a conversion of the produced mechanical energy into electrical energy. Equipped with a switchover option for operating an integrated lamp or external loads or feeding electrical energy for operation as a heat pump or refrigerating machine in accordance with the direction of rotation of the Stirling engine. Includes an alcohol burner (U10051).

Deluxe Quantitative Stirling Engine

For quantitative demonstrations and investigations of thermodynamic cycles, the reversibility of which can also be shown.

The Stirling Engine can be operated as:

- Thermal engine
- Heat pump
- Refrigerator

| | |
|-------------------------------|--|
| Motor-generator unit: | max. 12 V DC |
| Two-stage belt pulley: | 30 mm Ø, 19 mm Ø |
| Power of the Stirling engine: | approx. 1 W |
| Volume: | 32 cm ³ to 44 cm ³ |
| Flywheel diameter: | 140 mm |
| Dimensions: | 300 x 220 x 160 mm |
| Weight: | 1.5 kg |

1002594 \$1,165.00

Additionally Recommended:

| | | |
|-------------------------------------|----------------|-----------------|
| DC Power Supply | 1003311 | \$348.00 |
| Datalogging Differential | 3004200 | \$249.99 |
| Thermometer • IR Thermometer | | |

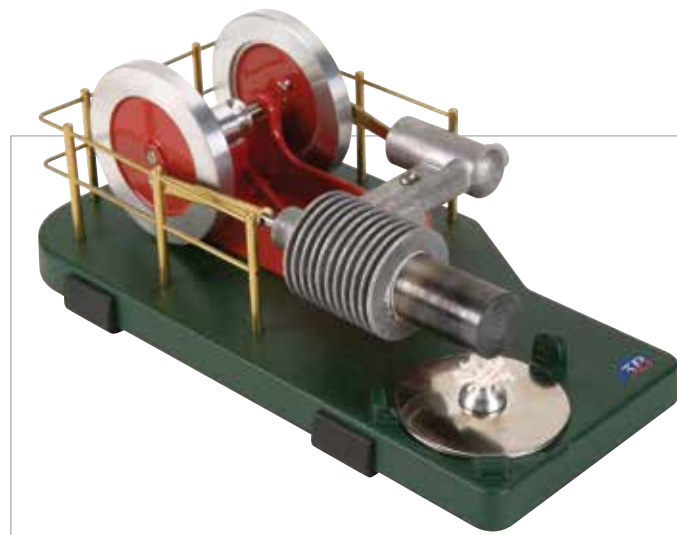

➤ An exciting classroom demonstration!

Simple Stirling Engine

This affordable Stirling Cycle Engine measures 7 x 4.25 in. and comes complete with built-in alcohol burner. Red flywheels and chassis mounted on a green base, this all-metal engine runs silently at speeds in excess of 1,000 RPM and is sure to attract your student's attention and inspire awe. This model comes completely assembled and ready to run, accompanied by our "Stirling Cycle Engines" book which explains the principles of operation. Weight: 0.65 kg

1003505 \$139.00



Steam Engine, transparent housing

Used to demonstrate how an oscillating steam engine operates. In this engine the cylinder moves around a center axis. This motion causes the inlet port and outlet port of the steam conduit to open and close. The base plate and flywheel are made of plexiglass, the boiler and working cylinder are made of heat-proof quartz glass, making all of the moveable parts and actions very clearly visible. With a ball-bearing supported crankshaft made of brass and a safety valve built into the boiler to prevent excessive pressure. Including alcohol burner.

Rotation speed: 800 rpm.
 Mech. power: 1 W
 Boiler volume: 50 ml
 Run time per load: 20 up to 25 min.
 Max. operating pressure: 0.5 bar

1002597 \$1,347.00

Replacement Items:

Spirit Lamp

Made of metal, with a knurled screw for feeding the wick and cap for extinguishing the flame.

Contents: 60 ml
 Dimensions: 55mm x 65 mm dia.
 Weight: approx. 50 g

1003565 \$26.00



Wick (not shown)

Spare wick for the U8621240 spirit lamp.

Length: 100 mm
1001048 \$5.00



Sun Runner Stirling Engine

The Sun Runner, a solar-powered Stirling Engine, offers a dramatic demonstration of energy conversion. This motor and its parabolic mirror can be attached to any conventional camera tripod. When properly aimed at the sun, the polished aluminum parabolic mirror focuses incoming solar energy on the heat cap of the engine, which is converted to rotary motion. Unit comes complete with motor, parabolic mirror, and wrenches. Standard camera tripod is not supplied. This engine is completely assembled and ready to run. Each unit is test run at the factory prior to shipping. Motor runs at 2,000 RPM and up. This engine can also run as a horizontal engine with an alcohol burner. Demonstrate this exciting method of harnessing the sun's clean and renewable energy to your students. Weight: 6.00 lbs

Dimensions:

Engine: 8.25 x 3 inches (L x W)
 Flywheel: 3.25 in
 Parabolic Mirror: 18 in diameter

3004557 \$259.00

➤ **Attach to a tripod during strong sunlight to run at approximately 2000 RPM!**



OPTICS



Interferometer

This complete set of high quality components comes on a heavy duty base to allow precise and reproducible measurements. The large optical components make it possible to produce clear, sharp interference patterns and conduct the experiments during daylight. Positions for the optical elements are predetermined so set up is easy and configurations can be quickly changed. The set includes a plastic box for convenient storage of the assembled interferometer.

Baseplate

Weight: 5.5 kg
 Height: 25 mm
 Dimensions: 245 x 330 mm

Optical components

Beam divider: 40 mm Ø
 Evenness: Frontside 1/10 λ. Backside 1/4 λ.
 Mirror: 40 x 40 mm
 Evenness: < 1/2 λ

Mirror adjustment

Eccentric-reduction: 1:1000
 (1 Micrometer-division mark corresponds to a mirror movement of 10 nm)

1002651 \$3,306.00

Additional Items Required:

He-Ne-Laser 3001497 \$600.00

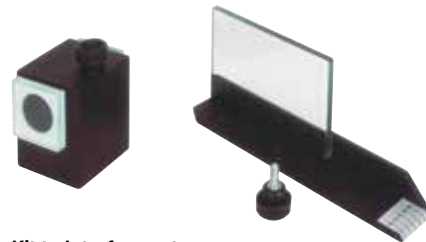

Accessory Kit to Interferometer

Accessory Kit to Interferometer U10350 containing vacuum cell to measure the index of refraction of air and glass plate on rotating holder to set up a Twyman-Green-interferometer.

1002652 \$549.00

Mach-Zehnder-Interferometer

Complete equipment set consisting of two beam splitters, two surface-coated mirrors, two observation screens and four polarisation filters. The highgrade optical components mounted on a heavy, rigid base plate for precise and reproducible measurements. Behind the first beam splitter, the two beams arrive on separate paths at the second beam splitter, where they are again superimposed. Therefore, the sub-beams can be polarised differently by introducing polarisation filters.

Beam splitter

Diameter: 40 mm
 Evenness: $\lambda/10$ (front side), $\lambda/4$ (rear side)

Surface-coated mirror

Dimensions: 40x40 mm²
 Evenness: < $\lambda/2$

Polarisation filter

Diameter: 30 mm
 Adjustable range: $\pm 105^\circ$
 Material: Glass (2x), foil (2x)
 Angular graduation: $3^\circ, 15^\circ$

Base plate

Weight: 5.5 kg
 Dimensions: 245 x 330 x 25 mm³

1014617 \$3,184.00

Additional Items Required:

He-Ne-Laser 3001497 \$600.00



CCD HD Sensor

Optical sensor for investigating distribution of light intensity. Particularly well suited for the investigation of light diffraction at single slits, multiple slits or diffraction gratings. User-friendly measurement and evaluation software enable simultaneous recording and analysis in real-time. The built-in software for Windows 2000/XP/Vista/7/8 32- and 64-bit versions starts running as soon as the sensor is connected to the computer via a USB cable. Includes attenuating filter, stand rod and plug-in power supply.

Software:

Data acquisition possible in two modes:
 Intensity as a function of location, e.g. for diffraction and interference.
 Intensity in a region as a function of time.
 Pointer mode, model calculation mode, spreadsheet and report modes are all available for the purposes of evaluation.

Sensor: Toshiba 3648 pixel SWB
 Resolution: 16 bits
 Integration time: 0.1 ms to 6.5 s
 Filter attachment: Clix (magnetic ring)
 Sensitive surface of sensor: 8 μm x 30 mm
 Interface: USB 2.0

1018820 \$1,029.00

Additionally recommended:

- 1003201 Laser Diode, Red**
- 1003203 Component Holder**
- 1008664 Diffraction Apertures on Glass Plate**
- 1008665 Slits and Bars on Glass Plate**
- 1003204 Double Slits on Glass Plate**
- 1008666 Multiple Slits on Glass Plate**
- 1002628 Optical bench**
- 1002635 Optical rider (3x)**



Optical LED Lamp

Ultra-bright light source for experiments on optical bench and for projection. It consists of a metal housing with a condenser, a movable element for axial light adjustment and a holding stem with a screw mounting. Including plug-in power supply.

LED: 18 V, 10 W
 Plug-in power supply: 100 – 240 V AC, 50/60 Hz
 Condenser focal length: 100 mm
 Condenser diameter: 80 mm
 Shaft: 125 mm x 10 mm \varnothing
 Dimensions: approx. 240 x 115 x 220 mm³
 Weight: approx. 1.5 kg

1020630 \$504.00

2 Light Box P

Equipment set for the execution of bench-based optical experiments, consisting of a light box in a sturdy plastic housing and numerous optical components. The complete set is housed in sturdy styrofoam storage case. The light box has four light outlets: front, back, and two side outlets with hinged mirrors for experiments on color mixing and shadows.

Light box Specifications:

- Lamp: 12 V, 36 W
- Connections: 4-mm socket
- Light box: approx. 17.5 x 10.0 x 6.5 cm
- Storage case: approx. 25 x 24 x 10 cm

1018471 \$186.25



Multiple Ray Projector, Magnetic

Demonstrate and experiment with geometric optics on magnetic boards. Light emitted from 1 to 5 light rays which are deflected via rotatable mirrors such that the light from the projector is parallel, divergent or convergent; for experiments on reflection, diffraction and lenses.

One to two divergent light rays, the overlap of which can be adjusted via mirrors, are available from the reverse side of the multiple-ray projector for experiments on shadow-casting and chromatics.

1003321 \$452.00

Spare Halogen Lamp (not shown)

Spare halogen lamp for multiple-ray projector U40110 12 V, 55 W.

1003322 \$19.00

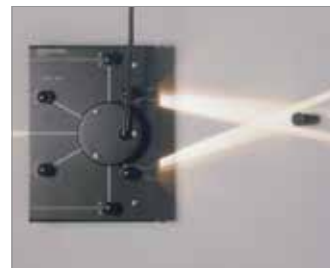
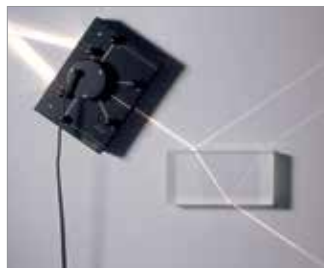
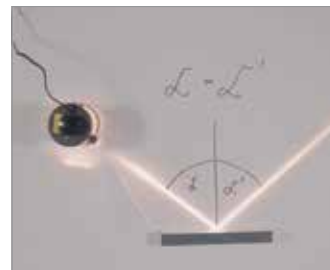
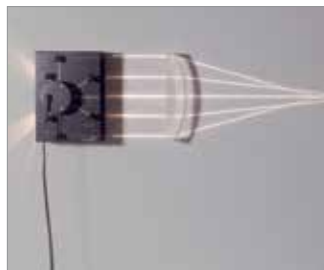

Experiment Topics:

- Laws of reflection
- Laws of refraction
- Total reflection
- Minimum deflection angle for a prism
- Focal determination of mirrors and lenses
- Laws of lenses and image errors
- Shadow casting



Digital Spectrometer LD

Digital spectrometer for quantitative analysis of emission and absorption spectra, for recording transmission curves and performing measurements in calorimetry and kinetics.

1018103 \$2,066.00



A. Single-ray Projector

For experiments on geometrical optics on magnetic boards.

With an adjustable slit apertures for creating light cone or thin ray for geometrical optics. In circular metal housing, rotatable on holder.

Lamp: 12V, 35W

Connecting line: 1.5 m long with 4 mm-plug

Dimensions: 120 x 70 mm Ø

Weight: 0.25 kg

1000682 \$388.00

Additionally Required:

B. Magnetic Holder

For mounting single-ray projector U40120.

1003323 \$65.00

Spare Lamp (not shown)

Spare lamp for single-ray projector U40120.

12 V, 35 W.

1003324 \$32.00

Visibility of Polarized Light in Turbid Water

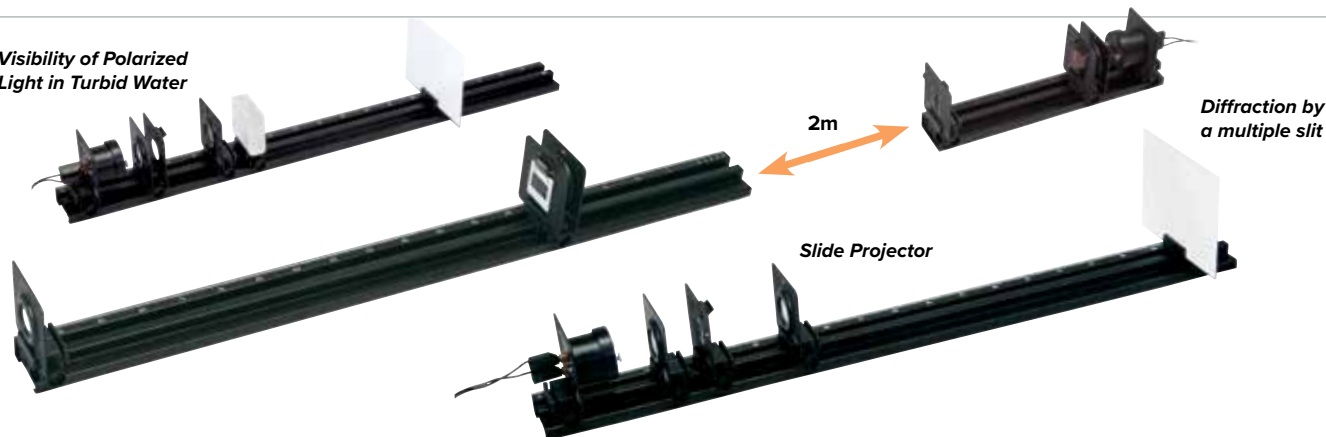

Kröncke Optical Systems

The Kröncke Optical System provides robust reliability that has been tried and tested for decades and offers all the precision needed for student exercises and practical courses in numerous experiments on ray and wave optics. The experiments are carried out in traditional fashion using the white light of an incandescent lamp, the filament of which can be projected through an adjustable slit to observe interference in particular. All optical components are mounted in diaphragms with no stems and can easily be adjusted vertically and with precision into the optical light path when mounted on optical riders. Optical riders can freely move on the U-profile rail of an optical bench and can be attached with a minimum of effort.

Ray optics:

- Pinhole camera
- Imaging with converging lenses
- Image aberrations
- Images in the eye (eye model)
- Correction of vision
- Magnifying glasses
- Microscopes
- Astronomical telescopes
- Terrestrial telescopes
- Slide projectors

Required equipment for ray optics:

Basic Set for Kröncke Optical System **1009931 \$691.00**

Polarization:

- Polarization of transverse waves
- Polarizer and analyzer
- Visibility of polarized light in turbid water
- Double refraction
- Rotation of planes of polarization by a sugar solution

Required equipment for polarization:

Basic Set for Kröncke Optical System **1009931 \$691.00**

Supplementary Set for Polarization

1009701 \$145.00

Interferences:

- Fresnel mirror
- Diffraction by small openings and plates
- Diffraction by an air gap
- Diffraction by the wire
- Diffraction by multiple slits
- Diffraction by the grating
- Optical resolution
- Determining the wavelength of light

Required equipment for interference:

Basic Set for Kröncke Optical System **1009931 \$691.00**
 Supplementary Set for Interference **1009700 \$463.00**



Basic Set for Kröncke Optical System

The experiments are carried out in traditional fashion using the white light of a halogen lamp, the filament of which can be projected through an adjustable slit to observe interference in particular. All optical components are mounted in diaphragms with no stems and can easily be adjusted vertically and with precision into the optical light path when mounted on optical riders. Optical riders can freely move on the U-profile rail of an optical bench and can be attached with a minimum of force.

1009931 \$691.00



Supplementary Set for Polarization

Supplementary set to the Basic Set for Kröncke Optical System (U8477120-115) for carrying out student experiments on the polarization of light waves.

Contents:

- 1 Pair of polarizing filters
- 1 Pinhole aperture, 10 mm
- 1 Rectangular cuvette

1009701 \$145.00



Supplementary Set for Interference

Supplementary set to the Kröncke Optical System basic set (U8477120-115) for carrying out student experiments on the interference of light waves.

1009700 \$463.00

Full content information available online at 3bscientific.com!

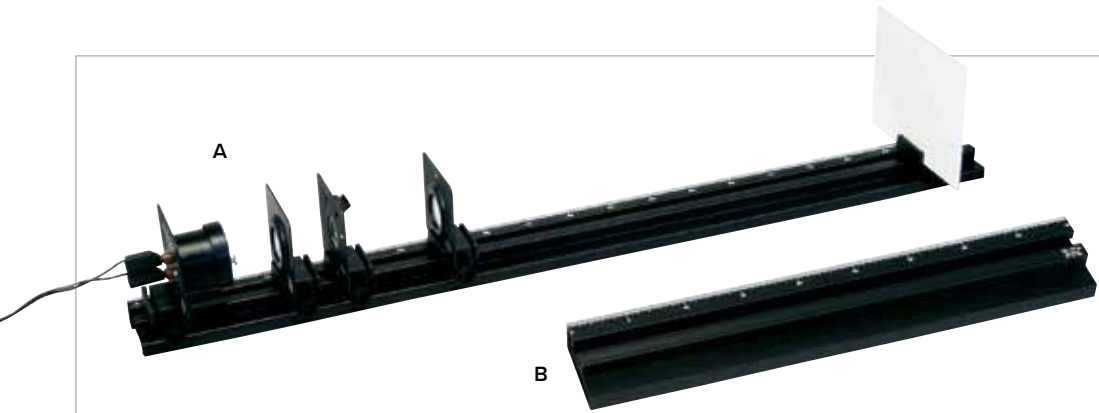

A & B. Optical Bench K

Optical bench comprising an aluminium U-shaped profile with a printed millimeter scale. Available in 2 sizes.

Crosssection: approx. 72 x 30 mm

A. 1000 mm 1.2 kg
1009696 \$84.00

B. 450 mm .06 kg
1009926 \$60.00

C. Optical Rider K

Optical rider for K-model optical benches (U8475240 and U8475337). With two clamps for diaphragms from the Kröncke Optical System or for plates up to 2 mm thick.

Dimensions: approx. 40 x 50 x 35 mm

Weight: approx. 70 g

1000862 \$28.00

Projection Screens K (not shown)

Plastic projection screens for mounting on K-model optical riders (U8475350).

Dimensions: 200 x 150 mm

Transparent Projection Screen K 1000878 \$14.00

White Projection Screen K 1000879 \$14.00

> Customize your own kit!



Iris Diaphragm K

Continuously adjustable iris on diaphragm screen 100 mm².

Aperture: 2 – 18 mm

Dimensions: 100 mm²

1000850 \$69.00



Optical Lamp K

Halogen lamp in cylindrical housing attached to diaphragm screen (100 mm²) for mounting on K-model optical riders (U8475350). The filament can be aligned horizontally or vertically.

Halogen lamp: 12 V, 20 W

Terminals: 4 mm safety sockets

Dimensions: approx. 60 x 100 x 100 mm

Weight: approx. 130 g

1000863 \$98.00

Additionally Required:

Transformer 12 V, 25 VA

1000865 \$64.00



Pair of Polarization Filters K

Two polarizing filters on a diaphragm screen (100 mm²) for producing and analyzing polarized light. In a rotating frame with a pointer and protractor scale.

Scale: 0 – 180°

Scale division: 5°

Dimensions: approx. 100 mm²

Filter diameter: 35 mm

1009929 \$159.00



Concave Mirror K

Concave mirror on diaphragm 100 mm².

Focal length: 180 mm

Mirror diameter: 50 mm

Dimensions: 100 mm²

1009925 \$50.00

Halogen Lamp 12 V/20 W (not shown)

Special substitute lamp for the optical lamp K (U8475400).

1003533 \$7.00

> Great equipment, great prices!



Clamp K

Clamp for diaphragms, filters, diffraction objects and other objects in a slide frame. On diaphragm screen (100 mm²).

Clamping range: 0, 2 – 10 mm

Dimensions: approx. 100 mm²

Round opening: 38 mm dia.

1008518 \$24.00



Adjustable Slit K

Continuously adjustable slit on diaphragm screen (100 mm²). The slit width can be adjusted by means of a micrometer screw.

Slit width: 0 – 4 mm

Slit height: 20 mm

Dimensions: approx. 100 mm²

Weight: approx. 190 g

1008519 \$284.00

Optical Lenses K

Lenses made of high-grade optical glass. Shock-proof and crack-proof installation in optical diaphragm (100 mm²). With focal length specification.

Dimensions: 100 mm²

Lens diameter: 50 mm



| Item Number | Shape | Focal Length | Price |
|-------------|--------------|--------------|--------------------|
| 1000869 | Convex Lens | 50 mm | |
| 1010300 | Convex Lens | 100 mm | |
| 1000871 | Convex Lens | 150 mm | |
| 1009866 | Convex Lens | 300 mm | \$28.00 ea. |
| 1009863 | Convex Lens | 500 mm | |
| 1009864 | Concave Lens | -100 mm | |
| 1009865 | Concave Lens | -500 mm | |



Fresnel Mirror K

Fresnel mirror for use on K-model optical benches (U8475337 and U8475336). Two mutually inclined surface-coated mirrors are bonded to a common metal plate. A knurled screw at the rear can be used to adjust the angle between the mirrors. The wave nature of light can be demonstrated by interference following reflection at both mirrors. Dimensions: 50 x 160 x 83 mm
Weight: 240 g
1009927 \$72.00



Plane Mirror K

Simple plane mirror, glass. Dimensions: 100 mm²
Weight: approx. 70 g
1003532 \$14.00



Prism Table K

Prism table with clip for clamping prisms. Holder fits K-model optical riders (U8475350).
1000876 \$33.00



Micrometer Screw K

Micrometer screw with fine tip for measuring diffraction and interference lines. Holder fits the optical rider K (U8475350). Dimensions: approx. 80 x 30 x 60 mm
Weight: approx. 120 g
1000887 \$104.00



Storage Box

Box made from smoked beech, varnished, with 20 compartments for lenses and optical elements of width 100 mm.

Dimensions: 400 x 130 x 90 mm³
Weight: approx. 1,000 g
1003571 \$79.00

➤ A truly unique and extraordinary lens

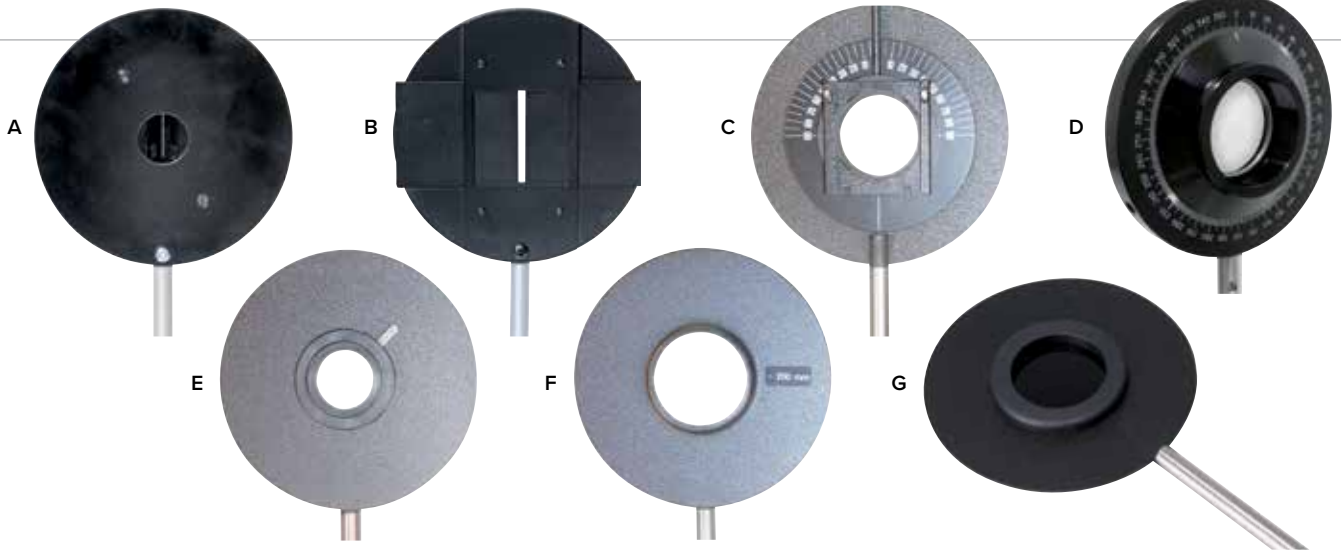

A. Adjustable Slit on Stem

Slit with symmetric aperture, in black metal frame on stem. With micrometer screw.

Holder diameter: 130 mm
 Slit width: 0 – 3 mm
 Slit height: 25 mm
 Shaft diameter: 10 mm

1000856 \$250.00

B. Object Holder

Holder with plug-in socket for flat, optical elements such as diaphragms, slits, gratings, filters and slides in black metal frame.

Diameter of metal frame: 130 mm
 Plug-in socket: 50 x 50 mm
 Shaft diameter: 10 mm

1000855 \$75.00

C. Rotating Object Holder

Same as U8474015 but rotating plug-in socket and angular scale.

Angular division: ±90°
 Divisions: 5°
 Diameter of the disc: 130 mm
 Rod: 10 mm

1003016 \$178.00

D. Polarization Filter on Stem

Precision glass polarization filter, which is in a mounting on a steel rod and can be rotated on a ball-bearing. With angular scale marked in 1° intervals.

Aperture diameter: 38 mm
 Extinction coefficient: >99.9 % at = 450 – 750 nm
 Height of optical axis: 150 mm
 Mounting diameter: 100 mm
 Stem diameter: 10 mm

1008668 \$181.00

E. Iris Diaphragm

In black metal frame, shaft-mounted. Continuously adjustable aperture.

Iris diameter: 3 to 29 mm
 Diameter of metal frame: 130 mm
 Shaft diameter: 10 mm

1003017 \$131.00

F. Shaft-Mounted Lenses

All lenses are mounted in a 130 mm black metal frame with a 10 mm rod to be placed in the rider on the optical bench. The lens has a rim around it to protect it from damage.

| Item Number | Shape | Focal Length | Lens Dia | Price |
|-------------|--------------|--------------|----------|----------|
| 1003022 | Convex Lens | +50 mm | 50 mm | \$111.00 |
| 1003023 | Convex Lens | +100 mm | 50 mm | \$110.00 |
| 1003024 | Convex Lens | +150 mm | 50 mm | \$110.00 |
| 1003025 | Convex Lens | +200 mm | 50 mm | \$110.00 |
| 1003026 | Convex Lens | +300 mm | 50 mm | \$110.00 |
| 1003027 | Concave Lens | -100 mm | 50 mm | \$110.00 |
| 1003028 | Concave Lens | -200 mm | 50 mm | \$110.00 |
| 1003029 | Concave Lens | +150 mm | 75 mm | \$158.00 |

G. Mounted Mirrors

All mirrors are mounted in a 130 mm black metal frame with a 10 mm rod to be placed in the rider on the optical bench. The lens has a rim around it to protect it from damage.

Diameter of frame: 130 mm
 Shaft diameter: 10 mm
 Lens diameter: 50 mm
 50 mm concave **1003031 \$130.00**
 50 mm convex **1003032 \$130.00**
 50 mm plane **1003033 \$130.00**



Storage Base for Lenses

With ten holes for storing lenses and other instruments with a rod of 10 mm.

1003034 \$86.00



Multi-component Holder

Two-piece holder, shaft-mounted, for mounting diffraction objects such as slits, double-slit, gratings, polarization foils, color filters, diaphragms, lenses etc. Optical components are secured by means of a metal ring equipped with two adjusting screws.

Diameter of holder: 80 mm
 Diameter of aperture: 36 mm
 Component diameter: 37 to 61 mm max

Shaft: 150 x 10 mm Ø

1003203 \$94.00



➤ **Engineered with high precision and detail**

Optical Riders

These riders accept rods from 10 mm to 14 mm in diameter. Two interior mounting springs allow optical components to be fixed to the optical axis even when the rider is not fixed to the optical bench. Our optical riders are manufactured with extremely high precision so that they can be attached to the optical bench in either direction and your optical components will remain aligned in the optical axis. Side mounting on optical riders allow you to place the riders as close together as possible.

| Item Number | Height | Base Width | Price |
|-------------|--------|------------|---------------------|
| 1002635 | 90 mm | 50 mm | \$198.00 ea. |
| 1002639 | 60 mm | 36 mm | |
| 1012467 | 60 mm | 50 mm | |
| 1002637 | 120 mm | 50 mm | |



Tilting Rider

For tilting optical elements out of the optical axis.

- Tilting range: 90°
- Sleeve height: 90 mm
- Base width: 50 mm
- Clamping width for rods: 10 to 14 mm

1012467 \$505.00



Cantilever Arm 100mm

Clamps to riders for positioning devices next to the optical axis. Optical rider sold separately. Extension arm: 100 mm Clamping width for rods: 10 to 14mm

1002646 \$158.00



Sliding Rider

For sliding of optical elements perpendicular to optical bench. Sliding range: ± 50 mm Height from optical bench: 90 mm

Width of base: 50 mm Clamping width for rods: 10 to 14 mm

1002644 \$420.00



Support for Optical Bench

Made of black anodized aluminum for adjusting the optical bench. Consisting of two feet and a single-point support with adjusting screws. Length of supports: 270 mm.

1012399 \$164.00



Optical Bench

Our new bench is 100% compatible with the traditional design which has been the standard for over 80 years in college and university laboratories. This means that all existing optical components such as riders will fit on these sleek and durable new benches. Machined with highest accuracy out of black anodized aluminum with an equilateral triangle cross section, these benches are sure to meet the most demanding requirements.

- Bore holes on front end for inserting elements or further rails
- V shaped standardized cross section
- Graduation: mm/cm and inches (opposite sides)

0.5 m, approx. 1.75 kg 1002630 \$228.00
1 m, approx. 3.5 kg 1002628 \$476.00
2 m, approx. 7 kg 1002629 \$599.00



Projection Screen

Translucent screen, shaft-mounted for all projection purposes on optical bench. Dimensions: 250 mm² Shaft diameter: 10 mm
1000608 \$69.00



Swivel Joint

For experiments where light is deflected and where the highest precision requirements prevail. Black anodized aluminum with adjustable protractor scale ±180° in 1° divisions.

Protractor scale: ± 90°
 Sleeve height: 60 mm
 Clamping width for rods: 10 to 14 mm
1002632 \$518.00

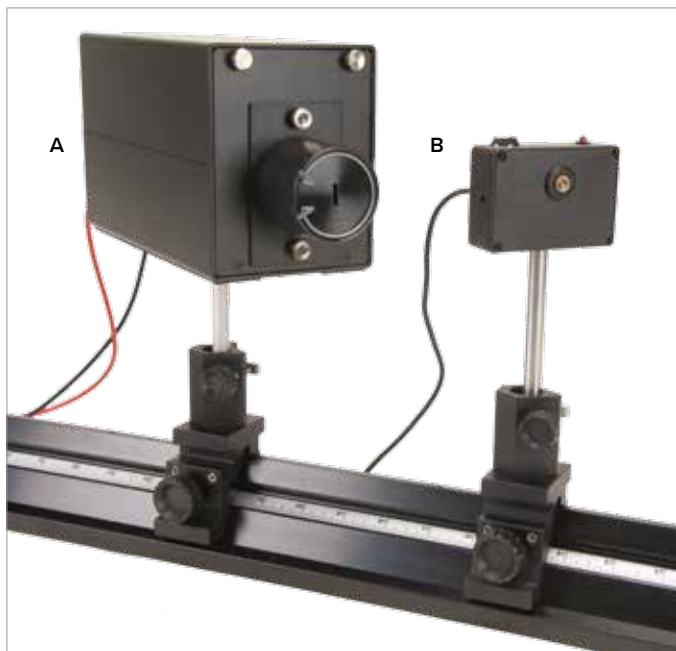

A. Compact Laser Diode

A new, extremely compact light source for use in optics, e.g. geometric optics and wave optics. Its small size allows use with many optical components on a shorter optical bench, thus providing an economical classroom solution. A laser with all security characteristics for the training and practical course application:

- Classified under laser class II, equipped with key switch
- Well visible LED display for lasers in operation
- Potentiometer for the regulation of power output on the max. output of 1 mW
- Power supply provided by plug-in contained in scope of delivery

Specifications:

| | |
|----------------------------|--|
| Power output: | 0.5 mW up to < 1mW Adjustable with potentiometer |
| Wavelength: | 650 nm \pm 3 nm |
| Beam diameter: | 2.5 mm of \pm 10% |
| Stability of power output: | \pm 5% in 24 h |
| Beam divergence: | < 2 mrad |
| Polarization: | random |
| Plug-in power supply: | 12V |
| Dimensions: | 50 x 72 x 54 mm |
| Rod staff: | 130 x 10 mm dia. |

Includes:

Diode laser with key switch, operating instructions, safety notes and plug power supply unit.

1003006 \$70.00

B. Optical Halogen Lamp, 12 V, 50 W

This extremely bright, universal light source is intended for use during experiments on the optical bench and for projection purposes. It consists of a metal housing with a condenser, a movable element for axial light adjustment, a holding stem with a screw mounting and an integrated fan.

Specifications:

| | |
|-------------------------|---------------------------|
| Halogen lamp: | 12 V, 50 W |
| Connection: | Via 4-mm safety jacks |
| Condenser focal length: | 75 mm |
| Condenser diameter: | 45 mm |
| Stem: | 120 x 10 mm \varnothing |
| Housing: | 190 x 125 x 110 mm |

1003188 \$420.00

Additionally Required:

Transformer 1000594 \$70.00



Laser Diode, Red

Red light source giving a beam with minimal divergence, housed in a compact and sturdy aluminium body. It is based on a 650 nm class II industrial laser module with a glass collimating lens. Fitted with a 10 mm stainless steel rod. A 100-230V AC/DC converter is included.

| | |
|----------------------------|-------------------|
| Laser protection class: | II |
| Output power: | 0.6 – 1mW |
| Wavelength: | 650 nm \pm 5 nm |
| Spot size at 5 m distance: | < 8 mm dia. |
| Divergence: | < 1 mrad |
| Operating voltage: | 6 – 12 V DC |

1003201 \$170.00

Laser Diode, Green

High performance 532 nm green laser (doubled NdYag). The laser (safety classification II) produces green light ideally suitable for optical demonstrations, as the wavelength is in the range where the human eye has maximum sensitivity. The visibility is as good as that for red laser light from a 5 mW source. Fitted with a 10 mm stainless steel stem. The apparatus supplied includes a plug-in mainadapter power supply.

| | |
|----------------------------|---------------------|
| Laser protection class: | II |
| Output power: | 0.4 – 1mW |
| Wavelength: | 532 nm \pm 0.1 nm |
| Spot size at 5 m distance: | < 9 mm dia. |
| Divergence: | < 2 mrad |
| Operating voltage: | 3 V DC |

1003202 \$352.00



Optical LED Lamp

Ultra-bright light source for experiments on optical bench and for projection. It consists of a metal housing with a condenser, a movable element for axial light adjustment and a holding stem with a screw mounting. Including plug-in power supply.

| | |
|-------------------------|---|
| LED: | 18 V, 10 W |
| Plug-in power supply: | 100 – 240 V AC, 50/60 Hz |
| Condenser focal length: | 100 mm |
| Condenser diameter: | 80 mm |
| Shaft: | 125 mm x 10 mm \varnothing |
| Dimensions: | approx. 240 x 115 x 220 mm ³ |
| Weight: | approx. 1.5 kg |

1020630 \$504.00

Spare Halogen Lamp, 12 V, 50 W (not shown)

Spare halogen lamp for experimental lamp 1003038.

1002837 \$5.00

Equipment Set for Wave Optics with Laser

Equipment set for demonstrating fundamental phenomena in wave optics by means of practical experiments.

The light source is provided by a partially polarised diode laser with adjustable mount. Power is supplied from a plug-in power supply (included) or from batteries. The components are magnetic and can be placed horizontally or vertically on the included metal board, according to the set-up required for the various experiments. All components are stored in a case with shaped foam inlay.

Diode laser: max. 1 mW, laser safety class II
 Wavelength: 635 nm
 Plug-in power supply: primary 100 V AC – 240 V AC secondary 3 V DC, 300 mA
 Battery holder: for 2 x 1.5 V AA batteries (batteries not included)

1003053 \$512.00

Contents:

- 1 Diode laser with adjustable mounting
- 1 Plug-in power supply
- 1 Battery holder (without batteries)
- 2 Mirrors with adjustable mounting
- 1 Half-silvered mirror
- 1 Screen, white
- 1 Screen, frosted glass
- 1 Convex lens
- 1 Polarization filter
- 1 Holder for lens and filter
- 3 Color filters in slide frames (red, green, blue)
- 2 Apertured diaphragms in slide frames
- 2 Square diaphragms in slide frames
- 3 Gratings with slits in slide frames
- 1 Cross grating in slide frame
- 1 Glass plate in slide frame
- 1 Holder for slide frames
- 1 Hologram
- 1 Metal board (60 x 45 cm²) with removable strut
- 4 Rubber feet for metal board
- 1 Storage case
- 1 Experiment guide

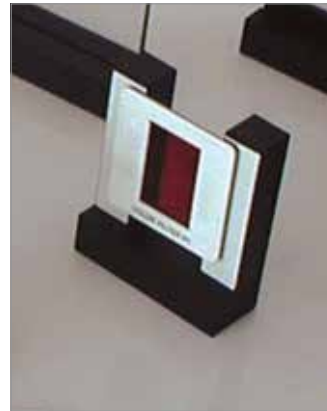

Modulated Helium-Neon Laser

Laser light can be modulated by varying its intensity. This laser is capable of up to 15% intensity variations at rates up to 1 MHz. The increased brightness can also help students make better holograms. Small movement or vibrations are less likely to blur the picture with a shorter exposure time.

Features:

- Beam can modulate from 85% to 100% of full power
- Accepts modulation signals ranging from 50Hz to 1MHz
- Effective signal transmission up to several hundred feet. With collimator and detector transmission range increases to thousands of feet
- Miniature phone jack accepts audio input signals at 100mV peak-to-peak level and 8K Ω impedance
- Two-year limited warranty

Power (mW): 1.0 min./2 typ./2.9 max.
 Beam diameter: 0.49 mm
 Beam divergence: 1.65 mRad
 Power Requirements: 105-125 Vac, 50-60 Hz, Class IIIA U.S. CDRH
3001497 \$600.00

Spectrum Tube Power Supply (115V, 50/60 Hz)

Control unit for stable operation of spectral tubes (U41810 – U41825). The integrated current limiter ensures a long service life of the tubes. Spring-contacts in fully insulated fixtures and a protective window guarantee secure mounting and reliable operation.

Voltage: 5000 V
 Maximum current: 10 mA
 Dimensions: approx. 370 x 120 x 90 mm³
1000683 \$483.00



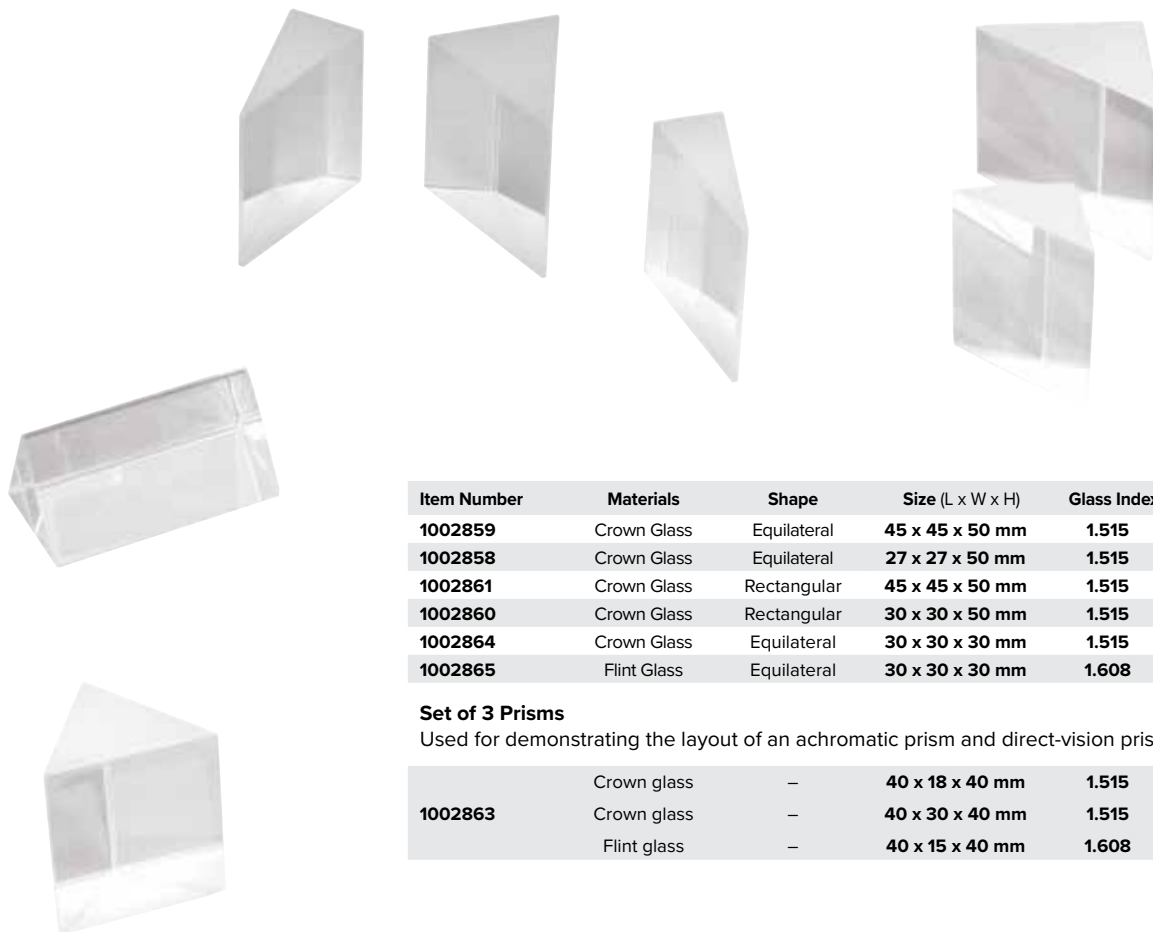

| Item Number | Materials | Shape | Size (L x W x H) | Glass Index | Price |
|-------------|-------------|-------------|------------------|-------------|---------|
| 1002859 | Crown Glass | Equilateral | 45 x 45 x 50 mm | 1.515 | \$70.00 |
| 1002858 | Crown Glass | Equilateral | 27 x 27 x 50 mm | 1.515 | \$33.00 |
| 1002861 | Crown Glass | Rectangular | 45 x 45 x 50 mm | 1.515 | \$58.00 |
| 1002860 | Crown Glass | Rectangular | 30 x 30 x 50 mm | 1.515 | \$57.00 |
| 1002864 | Crown Glass | Equilateral | 30 x 30 x 30 mm | 1.515 | \$59.00 |
| 1002865 | Flint Glass | Equilateral | 30 x 30 x 30 mm | 1.608 | \$89.00 |

Set of 3 Prisms

Used for demonstrating the layout of an achromatic prism and direct-vision prism.

| | | | | | |
|---------|-------------|---|-----------------|-------|----------|
| | Crown glass | – | 40 x 18 x 40 mm | 1.515 | \$274.00 |
| 1002863 | Crown glass | – | 40 x 30 x 40 mm | 1.515 | \$274.00 |
| | Flint glass | – | 40 x 15 x 40 mm | 1.608 | \$274.00 |

➤ Take your experiments to the highest level! 3B Scientific® quality prisms for precise results!



Round Cells

Duran glass cells with bonded optical discs and GL threads. For experiments on the determination of the angle of rotation of optically active substances on the optical bench.

Diameter: 35 mm

Thread: GL-14

100 mm long 1002884 \$80.00

200 mm long 1002885 \$71.00



Cell Holder on a Stem

Plastic holder for round cells U14313 and U14314.

Holder: 36 mm Ø

Stem: 90 mm x 10 mm Ø

1002721 \$48.00



Prism Table

Round prism table with adjusting clip, diameter 60 mm with a 10 mm rod. For mounting prisms and curves on the optical bench. Rider and prism sold separately.

1003019 \$100.00



Funhouse Mirror

The Funhouse Mirror is a high grade polyester sheet with vacuum deposited silver metal surface. The mirror is 8 mm thick; it will not tear but can be cut with normal scissors. Keep out of sunlight as it can focus light and heat to start fires. Comes rolled into 1.5" tube, will unroll flat. This is a great way to teach concave and convex mirrors and real and virtual images. Many applications, use your imagination!

Jumbo 137.16 x 213.36 cm **1003338 \$131.00**
 Large 60.96 x 132.08 cm **1003339 \$53.00**

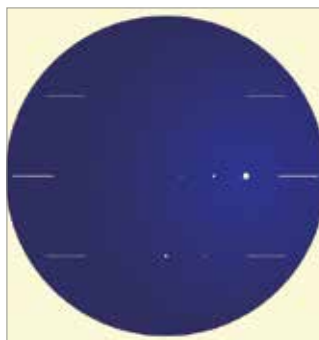

Diffraction Apertures on Glass Plate

Glass plates with 12 different single and double diffraction apertures for quantitative diffraction experiments. Diameter of support: 40 mm Aperture irregularities: < 1 μm

Single Apertures

Diameters: 20, 30, 50, 100, 200 & 500 μm

Double Apertures

Separations: 100, 200 and 400 μm

Rectangular Apertures

Diameters: 70 x 70 μm², 200 x 200 μm² and 70 x 200 μm²

1008664 \$87.00

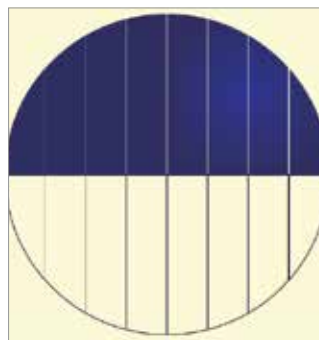

Slits and Bars on Glass Plate

Glass plates with 7 sets of slits and bars of different widths for quantitative diffraction experiments. Diameter of support: 40 mm

Irregularities: < 1 μm
 Slit widths: 30, 40, 60, 80, 100, 150 & 200 μm

Bar widths: 30, 40, 60, 80, 100, 150 & 200 μm

1008665 \$92.00

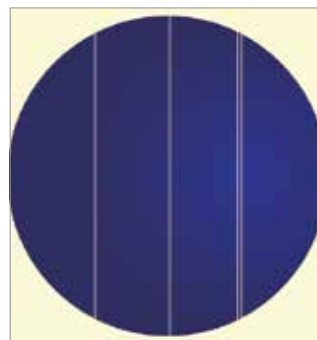

Double Slits on Glass Plate

Glass plates with three double slits of different separations for quantitative diffraction experiments. Diameter of support: 40 mm

Irregularities: < 1 μm
 Slit width: 70 μm
 Separations: 200, 300 and 500 μm

1003204 \$92.00



Multiple Slits on Glass Plate

Glass plates with four different numbers of multiple slits for quantitative diffraction experiments. Diameter of support: 40 mm

Irregularities: < 1 μm
 Slit width: 40 μm
 Slit separation: 100 μm
 Number of slits: 3, 4, 6 and 14

1008666 \$84.00

Additionally Required:

Component Holder

1003203 \$94.00



Hologram Kit

Are your students looking for excitement? With this kit they could be making holograms in no time. These transmission holograms are easy to make because of relatively lower sensitivity to vibrations. Set it up on a solid desk, turn off the lights and then hold your breath for 5 minutes while the special "Instant Hologram" film is exposed to laser light. Your hologram will then be visible under dim monochrome lighting. Follow the enclosed instructions carefully for satisfactory results.

Includes:

- SafetyLight Laser Diode (with heat sink)
- LED Darkroom Light (For seeing in the dark without exposing the film)
- "Instant Hologram" Film Plates (20 – 2 x 3")
- Laser-cut Holographic Plate Holder
- Laser-cut Laser Diode Mount
- Beam Spreading Lens
- Battery Pack and Batteries
- Object for Hologram
- Step-by-Step Instructions

3002992 \$186.00



A. Optical Disc with Accessories

This equipment set introduces the fundamentals of geometric optics. It consists of a base plate with an angular scale possessing 1° divisions, a block scale and two bores for mounting clamps for optical components (lenses, prisms, mirrors). An adjustable holder and tripod permit horizontal as well as vertical installation.

Includes:

- 1 Optical disc w/ a holding stem and 2 clamps, 240 mm Ø
- 1 Bi-concave lens, 90 mm
- 1 Bi-convex lens, 90 mm
- 1 Semi-circular element, 90 mm
- 1 Trapezoid element, 45° and 60°
- 1 Prism, rectangular, leg length 50 mm
- 1 Combined mirror (planar, convex, concave)
- 1 Storage case

1003036 \$400.00

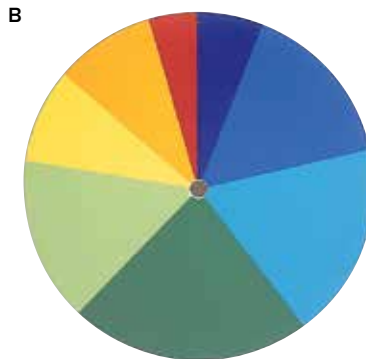

B. Color Disc

To demonstrate additive color mixing in conjunction with the motor with drive control (U11040). Plastic round disc with segments in the colors red, orange, yellow, bright green, dark green, light blue, dark blue and violet. The colors are mixed into the color white when the disc rotates.

Diameter: 170 mm
1002983 \$52.00

C. Motor with Drive Control

To operate the color disc (U15500). With disc holder and clamp for attachment to a stand rod. Including plug-in power supply.

Control range: 0 up to 25 rev/s
Rotation direction: reversible
Dimensions: 110 x 70 x 45 mm
Weight: 0.2 kg

1002705 \$220.00



Optics on magnetic boards!

With this demonstration equipment system experiments on light propagation and wave optics can be optimally performed. The optical components like lenses, mirrors, prisms and light sources can be attached in a matter of seconds directly to the magnetic whiteboards (U10030 or U10031) and experiments as well as measurements can be performed without having to darken the room. The size of the components guarantee that the experiments can be performed in larger lecture halls.



Have questions about our products?
Contact us at **1.866.448.5846** or
visit **3bscientific.com**

Optics on Magnetic Boards, basic kit

Basic kit for demonstration experiments on geometrical optics performed on magnetic boards, e.g. shadow-casting, laws of reflection, laws of refraction, total reflection, angle of least deflection in a prism, focal determination of mirrors and lenses, laws of lenses and image errors. Voltage supply, 12 V, 10 A

1000604 \$415.00

Includes:

- 2 Plane mirrors, magnetic
- 1 Plano-concave lens, magnetic
- 1 Plano-convex lens, magnetic
- 1 Plane-parallel plate, magnetic
- 1 Semi-circular body, magnetic
- 1 Right-angled prism, magnetic
- 1 Mirror model, convex-concave, magnetic
- 1 Set of 3 shadow-casting bodies, magnetic

Additionally Required:

| | | |
|---|----------------|-----------------|
| 2 Single-ray Projector | 1000682 | \$388.00 |
| 2 Magnetic Holder for Single-ray Project | 1003323 | \$65.00 |
| 1 Multiple-ray Projector | 1003321 | \$452.00 |

Set of 3 Shadow-casting Objects, magnetic

For experiments on shadow casting on magnetic boards.

Cube: 100 x 20 x 35 mm

Cylinder: 60 Ø x 35 mm

Cylinder: 15 Ø x 35 mm

1002992 \$78.00



Acrylic Glass Bodies, Magnetic

Height: 35 mm each. L = Length, W = Width, S = Side length, T = Thickness

| Item Number | Description | Focal Length | Dimensions | Price |
|-------------|--------------------|--------------|------------|---------|
| 1002986 | Plano-concave lens | 50 mm | - 400 mm | \$57.00 |
| 1002987 | Plano-convex lens | 36 mm | + 400 mm | \$57.00 |
| 1002988 | Plane-parallel | 36 mm | --- | \$65.00 |
| 1002989 | Semi-circular lens | 50 mm | + 200 mm | \$72.00 |
| 1002990 | Right-angled prism | 36 mm | --- | \$72.00 |

Magnetic Mirror

| Item Number | Description | Surface | Price |
|-------------|--|-------------|---------|
| 1002984 | Plane mirror, magnetic | 200 x 35 mm | \$49.00 |
| 1002985 | Mirror model, convex - concave, magnetic | 200 x 35 mm | \$57.00 |

Trolley Track

Track with two trolleys and other accessories for investigating linear motion, plus three adjustable point supports for setting horizontal alignment. The trolleys move with minimum friction on wheels with high-quality ball-bearings. They are fitted with magnets at their front ends for experiments involving both elastic and inelastic collisions.

Experiment Topics:

- Regular movements and movements with uniform acceleration
- Newton's laws of motion
- Conservation of energy
- Elastic and inelastic collisions

Refer also to experiments: UE1030250 and UE1030260

1018102 \$759.00





High Precision Spherometer

For measuring plate thicknesses, depressions and radii of curvature of spherical surfaces, e.g. lenses. The device consists of a tripod with three steel tips as feet, which form an equilateral triangle and a centered micrometer screw with a measuring tip. Attached to the micrometer screw is a disc with circular divisions from 0 to 500 and a vertical scale with millimeter divisions from 10 to 15 mm at the tripod.

Measuring ranges: 0 to 25 mm and 10 mm to 15 mm

Screw pitch: 0.5 mm

Measuring accuracy: 0.001 mm

Support spacing: 50 mm

1002947 \$355.00

Additionally Required:

Set of 10 Watch Glass Dishes – 80 mm 1002868 \$20.00

Set of 10 Watch Glass Dishes – 125 mm 1002869 \$24.00



Basic Spectrometer

Designed after Kirchhoff and Bunsen. For the observation and measurement of emission and absorption spectra. With adjustable aperture, condenser and flint glass prism. Ideal for schools and universities.

1002911 \$1,946.00

| | |
|-------------------------|--|
| Observation Tube | Moveable, with locking screw slideable eyepiece |
| Objective | 18 / 160 mm |
| Slit tube | Stationary, with symmetrical slit Objective: 18 / 160 mm |
| Scale Tube | Stationary, 200-division scale |
| Eyepiece | 18 mm aperture, 90 mm focal length |
| Scale | Can be calibrated in wavelengths |
| Prism | |
| Flint Glass | (60°) |
| Dispersion | C-F 2° |
| Length of Base | 20 mm |
| Height | 30 mm |
| Weight | 4.8 kg |

System Spectrometer-Goniometer

Spectrometer with rotatable prism or grating and directionally-adjustable objective tube for observing and measuring emission and absorption spectra. Can also be used for precise determination of the optical parameters of prisms or gratings.

1008673 \$2,076.00

| | |
|---------------------------------|---|
| Objective | Adjustable slit width and object distance; $f = 175 \text{ mm}$, 32 mm dia. |
| Eyepiece | Continuous focusing and viewing angle adjustment, eyepiece with crosswire, $f = 175 \text{ mm}$, 32 mm dia. |
| Prism | |
| Flint Glass | (60°) |
| Dispersion | ($n_F - n_C$): 0.017 |
| Length of base | 40 mm |
| Height | 40 mm |
| Transmission Grating | 300 lines/mm |
| Angular Scale | 0° to 360° Division 0.5° |
| Vernier Reading Accuracy | 0.5 angular minute |
| Weight | 12 kg |



| Item Number | Description | Line Count | Lattice | Slit/line | Slit Spacing mm | Price |
|-------------|--|------------|---------|-----------|-----------------|----------------|
| 1000596 | 3 double slits of different widths | - | - | 0.10 | 0.30 | \$16.00 |
| | | 0 pt | - | 0.15 | 0.25 | |
| 1000597 | 4 double slits of different spacings | - | - | - | 0.50 | \$16.00 |
| | | - | - | - | 0.75 | |
| | | - | - | - | 1.00 | |
| 1000598 | 2-, 3-, 4-, 5-fold slits and grating | - | - | 0.15 | 0.25 | \$16.00 |
| 1000599 | 3 gratings | 20 | 0.50 | - | - | \$16.00 |
| | | 40 | 0.25 | - | - | |
| | | 80 | 0.125 | - | - | |
| 1000600 | Grooved grating | 80 | 0.125 | - | - | \$16.00 |
| 1000601 | 2 cross gratings | 40 | 0.25 | - | - | \$16.00 |
| 1000602 | Single slit and line | - | - | 0.5 each | - | \$16.00 |
| | | - | - | 1.00 | - | |
| 1000603 | 3 hole and disc pairs of various diameters | - | - | 1.50 | - | \$16.00 |
| | | - | - | 2.00 | - | |

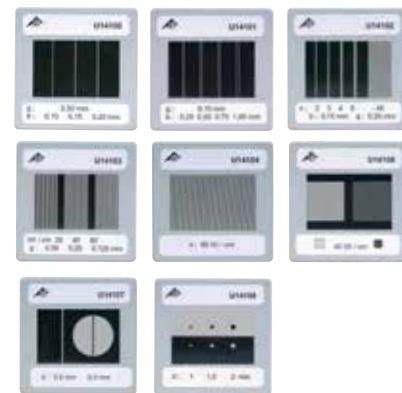

➤ Diffraction objects photographically prepared and mounted in slide frames.



Gratings

Examine the angle of diffraction and interference using these wire mesh gratings in slide frames.

- Dimensions: 50 mm²
- 140 Lines **1003178 \$15.00**
 - 530 Lines **1003179 \$20.00**
 - 600 Lines **1003180 \$18.00**
 - 1000 Lines **1003181 \$20.00**

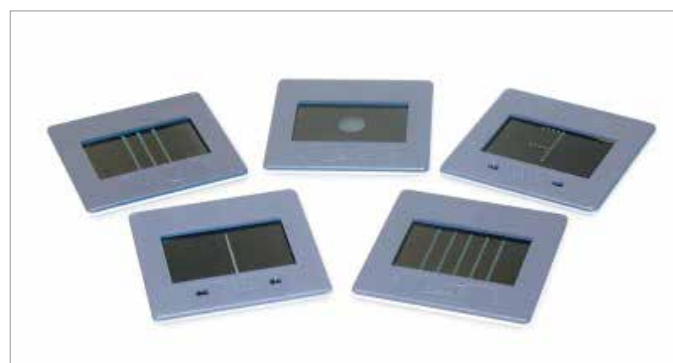

Set of Five Diaphragms

Consisting of:

- 1 slit:** Slit width 1 mm
 - 3 slits:** Slit width 1 mm
Slit spacing 5 mm
 - 5 slits:** Slit width 1 mm
Slit spacing 5 mm
 - "F" diaphragms:** Aperture of 8 mm
- 1000607 \$47.00**

Set of Four Diffraction Gratings (not shown)

These individual 35 mm slides contain 4 different diffraction gratings: 80, 100, 300 and 600 lines/mm. They are perfect for qualitative studies of the relationship between line spacing, wavelength and diffraction angle.

1003081 \$129.00



Color Filters, Primary Colors

Set of 3 color filters in slide frames: Red, Green, Blue.

Dimensions: 50 mm²
1003185 \$25.00

Color Filters, Secondary Colors

Set of 3 secondary color filters in slide frames: Cyan, Yellow, Magenta.

Dimensions: 50 mm²
1003186 \$25.00



Hologram

Transmission hologram in slide holder.

Dimensions: 50 mm²
1003177 \$59.00



➤ The multi-lingual software offers a wide range of functions!

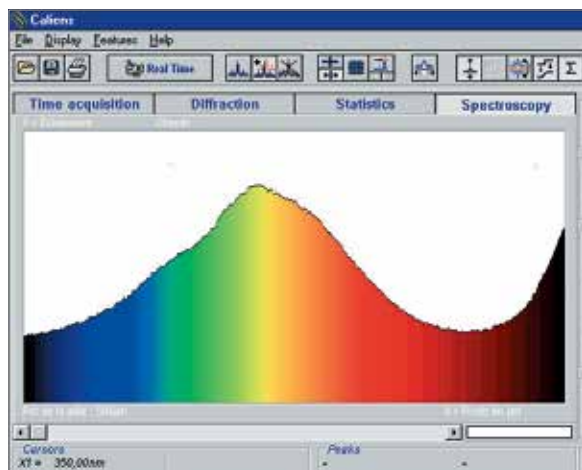
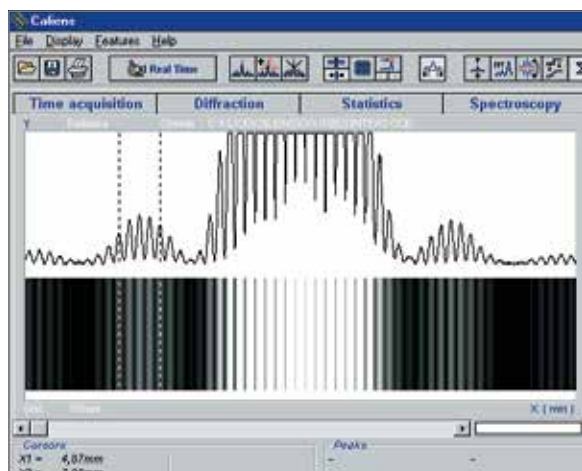

CCD Linear Camera

Intended for investigating all optical phenomena in real time, this precision CCD linear camera consists of a measuring head with a CCD linear array, as well as data acquisition accessories. The control unit can be connected directly to a PC. The scope of supply includes user-friendly software, neutral grey filters, patch cords and a storage case.

Measurement head with a CCD linear array:

Resolution: 2048 pixels (14 x 200µm)
 Sensitive length: 30 mm
 Neutral-grey filter: Density factor 3.0: black/white
 Rod: 170 x 10 mm Ø
 Integration time (remote or direct control): 5 to 42.5 ms – step 2.5 ms

- Real-time displays for observing time-dependent phenomena, for example, during experiment adjustments
- Adjustable sensitivity of the measuring head in accordance with the intensity of the light source
- Representation of the intensity distribution of interference spectra in diagrams and grey stages, as well as colored display of measured emission and absorption spectra
- Measurement functions such as adjustable axis scaling, grids, vertical and horizontal cursor with corresponding displays, peak-search routine with display of intensity and position, zoom
- Signal processing functions such as smoothing, averaging and inversion of spectra, Fast-Fourier Transformation
- Simulations for comparing theoretically calculated interference and diffraction intensity distributions with experimental data
- Storage, printing, online help and export of data and graphics (in the form of word processing, spreadsheet and bitmap files)

Spectrometer (Investigations of)

- Emission and absorption spectra
- Transmission curves of filters
- Spectral resolution of white light

Wave optics

Display and measurement of diffraction and interference spectra, for example, diffraction at a slit, pinhole, grating, Newton's rings, Fresnel mirrors; comparison of measured spectra with theoretical calculations.

Includes:

- CCD linear camera
- Neutral-grey filter
- Manual with experiment descriptions
- Software for data recording and evaluation
- USB Cable
- Transport case

1013311 \$1,545.00

Additionally Recommended:

| | | |
|---|----------------|-----------------|
| Diode Laser (115 V, 50/60 Hz) | 1003006 | \$299.00 |
| Component Holder on stem | 1003203 | \$94.00 |
| Diffraction Apertures on Glass Plate | 1008664 | \$87.00 |
| Slits and Bars on Glass Plate | 1008665 | \$92.00 |
| Double Slits on Glass Plate | 1003204 | \$92.00 |
| Multiple Slits on Glass Plate | 1008666 | \$84.00 |

| | |
|-------------------------------------|---|
| Computer Connection Via a USB Cable | |
| Refresh Rate | 20 fps |
| System Requirements | |
| Operating System | Windows 98 or Higher |
| Computer | 2mb of Free Hard-disk Space |
| Screen Resolution | At least 640 x 480 Pixels with 256 Colors |

Have questions about our products?
 Contact us at **1.866.448.5846** or
 visit **3bscientific.com**

Note: Laptop, Laser Diode, Optical Rider and Optical Bench not included



> Measure the speed of light!

Light Speed Meter

The oscillator for the LED light pulse, the photoreceptor and the calibrated quartz crystal oscillator generator accurately timed square-wave pulses are integrated into one compact housing. The transmitted signal is reflected via an internal and external reflector and superimposed onto the original signal. Due to this, the external main reflector, thanks to its numerous, small triple-prism reflectors, can be set up without difficulty simply judging by eye. The evaluation is carried out with a dual-channel oscilloscope capable of recording at least 70 MHz (e.g. U43569). On the basis of the determined differential delay, the speed of light can thus be calculated.

Scope of delivery:

- Basic unit including the oscillator, receiver and built-in mains supply
- Fresnel lens, shaft-mounted
- Triple-prism reflector, shaft-mounted

Contents:

- 1 Control unit with a transmitter, receiver and integrated power supply unit
- 1 Fresnel lens on shaft
- 1 Triple-prism reflector on shaft
- 3 HF cables, 1 m

1000881 \$816.00

Additionally Required:

| | | |
|--------------------------------|----------------|-------------------|
| Stand Base (3 required) | 1001045 | \$55.00 |
| Digital Oscilloscope | 3001448 | \$2,502.00 |
| Optical Bench, 0.5m | 1002630 | \$228.00 |
| Optical Rider, 60mm | 1012400 | \$198.00 |
| Optical Rider, 90mm | 1002635 | \$198.00 |

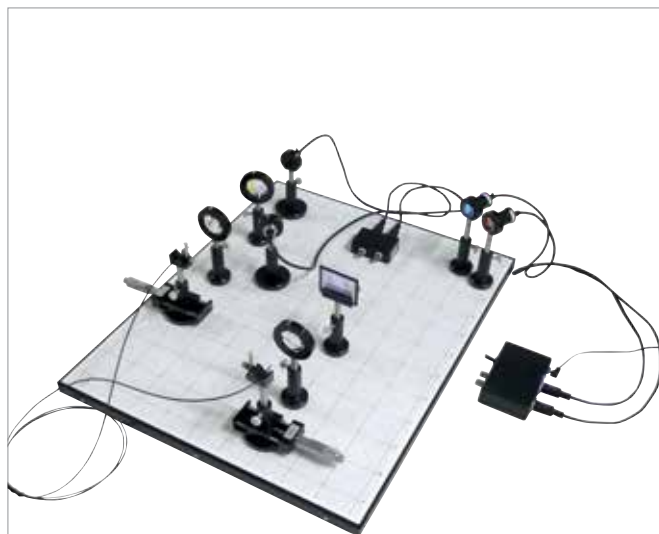

Optical Telecommunications Equipment Set

Complete experiment system for quantitative investigation of transmission of signals via optical media, plus the processes of optical multiplexing and demultiplexing. To build a two-dimensional optical system of high precision, a magnetic bench with a printed grid is provided, upon which it is possible to write.

Optical bench:

| | |
|--------------------|--------------------|
| Available surface: | 600 x 480 mm |
| Grid radials: | 0°, 45°, 90°, 135° |
| Grid subdivisions: | 5 cm, 1 cm |
| Weight: | 6 kg approx. |

Contents:

- 1 Optical bench, 600x480 mm, for attachment of magnetic components
- 8 Optical riders with magnetic base
- 2 Movable riders, l = 25 mm, with magnetic base
- 1 LED with collimating lens, in frame on stem, red
- 1 LED with collimating lens, in frame on stem, blue
- 1 Electronic signal transmitter, including power supply
- 1 Electronic signal receiver, including power supply
- 2 Phototransistors in housing on stem
- 1 Fiber-optic cable with SMA plugs, 1 m
- 1 Diffraction grating, 600 lines/mm
- 1 Dichroitic filter in housing on stem, blue
- 1 Dichroitic filter in housing on stem, yellow
- 2 Converging lenses in housing on stem, f = 50 mm, 40 mm dia.
- 1 Slide holder for gratings, on stem
- Component holders and spring clips

1008674 \$5,881.00

Additional Items Required:

| | | |
|--|----------------|-------------------|
| Spectrometry Supplementary Set | 1008675 | \$3,161.00 |
| Two-Channel Function Generator, 20 MHz | 1008677 | \$1,900.00 |
| Digital Oscilloscope, 4-Channel, 60 MHz | 1008676 | \$2,821.00 |

Spectrometry Supplementary Set (not shown)

Supplement to the Optical telecommunications equipment set for investigating spectrometry of transmitted signals and measurement of absorption losses.

Contents:

- 1 Spectrometer with SMA connectors
- 1 Reference light source with SMA connectors
- 5 Fiber optic cables with SMA plugs, 2 m
- 1 Fiber optic cable with SMA plugs, 10 m
- 5 SMA/SMA connectors

ATOMIC & NUCLEAR PHYSICS

> Use for the determination of Planck's Constant



Experiment Topics:

- Millikan's experiment
- Discrete nature (quantisation) of electric charge
- Elementary electric charge
- Charged oil droplets in an electric field
- Stokes viscous drag, weight, buoyancy
- Equilibrium voltage
- Velocity of fall and velocity of rise

Millikan's Apparatus (115 V, 50/60 Hz)

Compact apparatus for demonstrating the discrete nature (quantisation) of electric charge and for determining the elementary charge of an electron. Comprising an experiment chamber kit for assembly with plate capacitor and connected oil atomiser, lighting unit with two green LEDs, measuring microscope, voltage adjustment knob and switch to set the capacitor voltage, switch for starting and stopping rise and fall time measurements and a display unit with touch screen. Measurements can be made using the floating method or the rising and falling method. Measured rise and fall times for a charged droplet of oil are displayed on the touch screen along with the configured voltage. Parameters relevant to the evaluation of the results, temperature, viscosity and pressure are also displayed. Includes plug-in power supply, 12 VAC, 1 A.
 Dimensions: 370 x 430 x 235 mm³
 Weight: approx. 4.3 kg

Contents:

- 1 Basic apparatus with experiment chamber and display unit
 - 1 Measuring microscope
 - 1 Oil atomiser
 - 50 ml of oil for Millikan's apparatus
 - 1 Plug-in power supply, 12 VAC, 1 A
- 1018882 \$2,663.00**

Advantages:

- Compact instrument with built-in measurement and display unit
- Touch-sensitive screen for simple and ergonomic operation
- Maintenance-free lighting unit for uniform lighting via two green LEDs
- Built-in pressure and temperature sensor for automatically determining the relevant parameters, temperature, viscosity and pressure

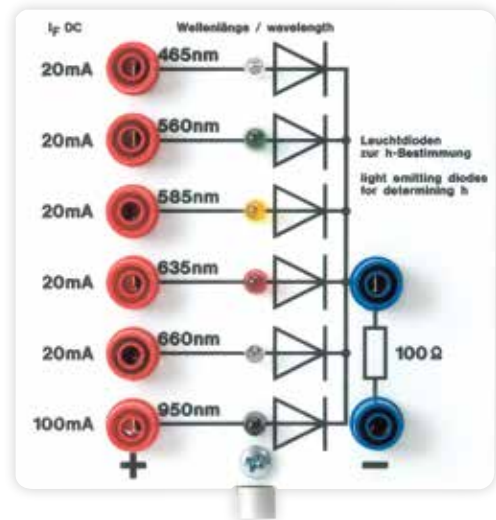

Light-Emitting Diodes (LEDs)

Used for determining Planck's constant h by measuring the diffusion potential of differently colored LEDs as a function of the wavelength or frequency. Six colored LEDs of different emission wavelengths with integrated series resistor mounted on carrier plate with shaft.

| | | |
|--------------|----------------|----------------|
| Wavelengths: | 480 nm, blue | 560 nm, green |
| | 590 nm, yellow | 635 nm, orange |
| | 655 nm, red | 950 nm, IR |

Series resistor: 100 Ohm, 1%
 Voltage: Max. 6 V
 Dimensions: 115 mm²
 Weight: approx. 120 g

1000917 \$318.00

Additionally Required:

- A. Power Supply** 1003311 \$348.00
- B. Multimeter** 3004188 \$49.99
- C. Stand Base** 1001046 \$37.00
- D. Patch Cords** 1002840 \$94.00



A



B



C



D

Observation Spectroscopes with Graduated Scales: These spectroscopes have been specially developed to allow users to observe the spectrum of light traversing through a slit refracted by a grating of 530 lines / mm. The superposition of the obtained spectrum on the graduated scale of the spectroscope permits the measurement of the main wavelengths of light from spectral lamps.



Gadischarge Tube, Large

For observing luminescence during electric discharge in gases at reduced pressure, and investigating cathode rays and canal rays occurring at low pressures outside the discharge path. Glass tube with graded seal, dish-shaped, perforated electrodes and 4 mm-jacks for connecting the voltage supply. Gas not included. Experiment set up is shown with vacuum pump and power supply which are not included.

Material: Glass
 Dimensions: 700 x 4 mm Ø
 Vacuum connection: Graded seal NS 19/26
1002905 \$352.00



Planck's Constant Apparatus

Simple, safe and quick-to-operate, compact apparatus with integrated photocell as well as a voltmeter and nano-ammeter for determining Planck's constant and the work done in emitting an electron using the stopping potential method. Five light emitting diodes (LEDs) of known mean wavelengths act as light sources of differing frequencies. The intensity of the light emitted by them can be varied from 0 to 100%.

Wavelengths: 472 nm, 505 nm, 525 nm, 588 nm, 611 nm
 Dimensions: 280 x 150 x 130 mm³
 Weight: approx. 1.3 kg

Contents:

- 1 Basic apparatus with photocell, voltmeter, nano-ammeter and power supply for light sources
- 5 LEDs in casings with connector leads
- 1 Plug-in power supply 12 V AC

1000536 \$1,272.00

Spectroscope in Cardboard Box

Hand spectroscope in a flat cardboard box with built-in wavelength scale for direct reading of coarse wavelengths for spectral lines and spectra. 180 x 115 x 25 mm

1003183 \$33.00

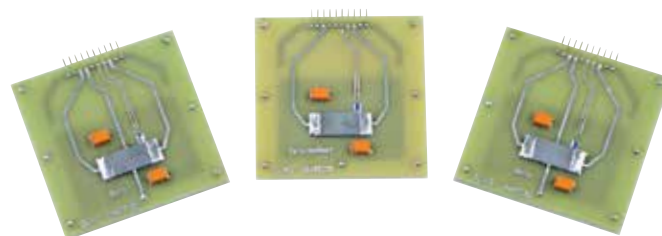

Germanium on Printed Circuit Board

Interchangeable board with a germanium crystal for investigating the conductivity of germanium as a function of temperature. With contacts for transverse current, integrated resistive heating element with temperature sensor directly under the crystal, and multi pin plug for connecting the circuit board to the basic Hall effect apparatus (U13114).

Crystal dimensions: approx. 20 x 10 x 1 mm
 Overall dimensions: approx. 100 x 100 x 10 mm
 Weight: approx. 200 g

Undoped Germanium 1008522 \$760.00
P-Doped Germanium 1009810 \$760.00
N-Doped Germanium 1009760 \$760.00

➤ **Electron spin resonance and nuclear magnetic resonance in a simple kit for your lab!**



ESR/NMR Basic Set

This basic equipment set is intended for investigating the electron spin resonance (ESR) of an unpaired electron of a DPPH sample as well as the nuclear magnetic resonance (NMR) of glycerine, teflon and polystyrene. Resonances are observed via transitions induced through high frequencies resulting from changes in the external magnetic field. Resonance absorption curves can be represented with a simple dual-channel oscilloscope.

Contents:

- 1 Basic unit
- 1 Pair of coils
- 1 Control panel
- 1 Plug-in power supply, 12 V AC (115 V, 50/60 Hz)

The basic unit is a mechanical base for test samples as well as ESR (from U188501) or NMR probes (from U189021), a coil pair and a permanent magnet (from U189021).

Dimensions: 165 x 105 x 135 mm³ approx.
Weight: approx. 1.25 kg

The coil pair is used to generate the variable magnetic field for electron spin resonance and – in conjunction with the permanent magnet (from U189021) – nuclear spin resonance.

Magnetic flux density: 0 – 3.7 mT
Connection: Barrel connector

Dimensions: approx. 20 mm x 74 mm dia.
Weight: approx. 0.2 kg each

The control console provides the voltage for control and supply of power to probes and the coil pair. It also processes the signal for display on an oscilloscope and indicates the frequency of the high-frequency signal.

Probe connection: Four-pin lemo socket
Coil pair connection: Saw-tooth current source, 0 – 250 mA, 50 ms, pair of barrel sockets

Field output: Proportional to coil current, 0 to 1 V, BNC socket
Signal output: Resonance signal, 0 to 1 V, BNC socket

Frequency range: approx. 45 to 75 MHz (ESR)
approx. 10 to 15 MHz (NMR)
Dimensions: approx. 170 x 105 x 45 mm³
Weight: approx. 0.5 kg

1000637 \$2,160.00

Additionally Required:

| | | |
|--------------------------------------|----------------|-------------------|
| ESR Supplementary Set | 1000640 | \$552.00 |
| NMR Supplementary Set | 1000642 | \$1,664.00 |
| Analog Oscilloscope, 2x30 MHz | 3001445 | \$738.00 |



NMR Supplementary Set

Supplementary set for ESR/NMR basic set (U188031) for experiments on nuclear magnetic resonance using three different samples. Consists of an NMR probe-head with radio frequency coil, a permanent magnet giving a highly uniform field, a sample of glycerine, a sample of polystyrene, a sample of Teflon, an empty sample tube for comparison and two mounting discs.

Connection to the probe-head: Four-pin lemo plug
Magnetic flux density of permanent magnet: approx. 300 mT

1000642 \$1,664.00



ESR Supplementary Set

Supplementary set for ESR/NMR basic set (U188031) for experiments on electron spin resonance using DPPH. Consists of an ESR probe-head with radio frequency coil, a sample of DPPH (diphenyl picryl hydrazyl), an empty sample tube for comparison, two mounting rings, and two mounting cylinders.

Connection to the probe-head: Four-pin lemo plug

1000640 \$552.00

Experiment Topics:

- Extrinsic conductivity
- Intrinsic conductivity
- Mobility of electrons and holes
- Drift velocity of charge carriers
- Carrier concentration
- Band separation



Basic Hall Effect Basic Apparatus

Basic apparatus for attaching contacts and supplying voltages to germanium crystals on printed circuit boards (U13111 – U13113) for experiments on the measurement of Hall potentials and conductivities at different temperatures. With stem for setting up the apparatus between the pole-shoes of the transformer assembly kit. Built with integrated adjust-able constant-current source, amplifier for temperature measurement, automatic heater cut out to protect the crystal, and compensation circuit with matching and cut out functions for offset voltages.

Heater voltage: 15 V DC, 2 – 4 A
 Constant-current source: 12 V DC, 40 mA
 Output signals: Hall potential, temperature, voltage drop across crystal
 Connections: 4 mm safety sockets
 Dimensions: 150 x 250 x 50 mm approx.
 Weight: approx. 0.5 kg

1009934 \$830.00

Additionally Required:

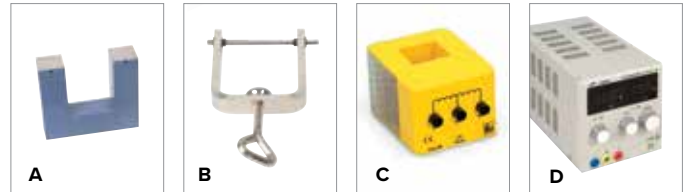

A. U-core with Yoke

1000979 \$149.00

B. Pair of Clamps

1000977 \$50.00

C. Coil with 600 Turns (2x)

1000988 \$140.00

D. DC Power Supply 0 – 20 V, 0 – 5 A (115 V, 50/60 Hz) (2x)

1003311 \$348.00

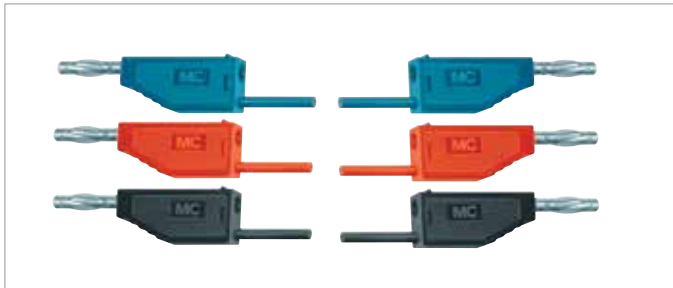

Set of Patch Cords for Tube Experiments

Seventeen maximum-quality patch cords with 4 mm-connectors for all cabling between tubes, power supplies, display units and coils.

Wire crosssection: 1 mm²
 Continuous current: Max. 19 A
 Plug and jack: 4 mm (nickel-plated)

1002847 \$115.00

| Quantity | Length | Color | Connection |
|----------|--------|-------|------------|
| 2 | 75 cm | Red | Jack/Plug |
| 4 | 75 cm | Blue | Plug/Plug |
| 2 | 75 cm | Black | Plug/Plug |
| 2 | 75 cm | Blue | Plug/Plug |
| 5 | 75 cm | Black | Plug/Plug |
| 2 | 75 cm | Red | Plug/Plug |



Photocell

Photocell for demonstrating the photoelectric effect which shows that the emission of electrons increases with increasing light intensity. Mounted ready for use on a base plate with electrical wiring and clamping bar. Available gas filled or in a vacuum.

Vacuum Photocell 1000915 \$382.00
Gas Photocell 1000916 \$416.00

| Photocells | 1000915 | 1000916 |
|---|----------------------------|----------------------------|
| Cathode | Caesium on oxidized Silver | |
| Cathode Area | 2.4 cm ³ | |
| Wavelength for Maximum Sensitivity | 850 nm | |
| Operating Voltage | 50 V, max. 250 V | |
| Working Resistance | 1 M | |
| Dark Current | <0.05 μA | <0.01 μA |
| Sensitivity | | 125 μA/lumen |
| Photoelectric Current Density | max 3.0 μA/cm ³ | max 0.7 μA/cm ³ |

➤ **View alpha particles, lower energy beta particles, and electrons!**



No dry ice required!

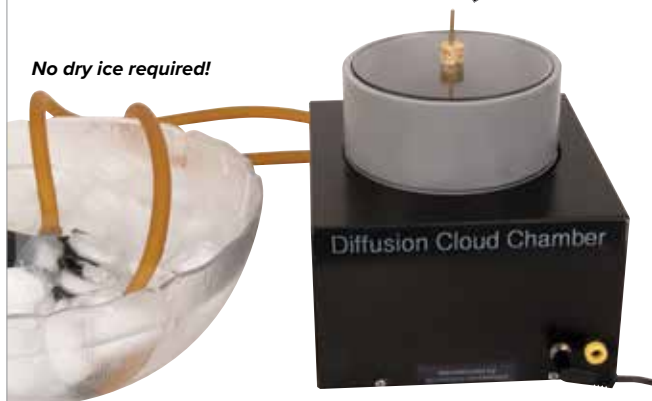

Diffusion Cloud Chamber

The Model 500 Diffusion Cloud Chamber is used to view high energy alpha particles, lower energy beta particles, and electrons. Sources such as radioactive material, cosmic rays and other forms of naturally occurring radiation can be studied with this device.

The bottom of the chamber is cooled by circulating ice water through the base and further cooling it to -35°C with a Peltier device. Alcohol placed in the chamber wicks up the inside chamber lining where it evaporates in the warmer region of the chamber and diffuses downward. The alcohol vapor is then cooled near the chamber bottom and becomes super-saturated. As energetic alpha and beta particles from a radioactive source pass through the alcohol vapor, the vapor condenses, forming droplets which appear as tracks in the strong chamber crosslighting.

Unlike most cloud chambers on the market, this unit does not use dry ice! Simply connect the unit to a source of cold running water, or use the included pump and a container of ice water and your experiments will run for hours! With visible tracks showing in as little as 15 minutes, the Model 500 Diffusion Cloud Chamber is a wonderful demonstration tool that can be easily set up and operated just about anywhere!

3002054 \$450.00

Features:

- Uses ice water instead of dry ice
- Water circulation pump
- Built-in high voltage (~800V) power supply for clearing the chamber of unwanted ions
- Powered by 12V DC power adapter
- Built-in LED Lamps for illuminating the particle trails

Includes:

- Cloud Chamber (5" diameter)
- 12 VDC Power Adapter (6 A)
- Water Circulation Pump
- 2 Rubber Hoses
- Extraction Pipette and Funnel
- Internal Clearing Field Generator
- Radioactive source
- Beta deflection
- Ionising particles
- Mesons
- Cosmic radiation
- Radioactive decay
- Decay series
- Particle velocity
- Lorentz force

What you can learn about:

- Alpha, Beta, Gamma-particles

Fine Beam Tube on Connection Base R

Experiment Topics:

- Deflection of electrons in a closed circular path inside a magnetic field
- Determination of specific charge of an electron e/m

For examining the deflection of electron beams in a uniform magnetic field using a pair of Helmholtz coils (1000906) and for the quantitative determination of the specific charge of the electron e/m . Glass vessel with integrated electron beam system, consisting of an indirectly heated oxide cathode, a Wehnelt cylinder and a perforated anode, in neon residual gas atmosphere with precisely set gas pressure and with integrated measurement marks for parallax-free determination of the diameter of the fine beam. Gas atoms are ionized along the electron path and produce a sharply defined, visible fluorescent beam. Tube mounted on base with color coded connectors.

| | |
|-------------------------|--|
| Gas filling: | Neon |
| Gas pressure: | 1.3x10 ⁻⁵ hPa |
| Filament voltage: | 5 – 7 V DC |
| Filament current: | < 150 mA |
| Wehnelt voltage: | 0 – -50 V |
| Anode voltage: | 200 – 300 V |
| Anode current: | <0.3 mA |
| Circular path diameter: | 20 – 120 mm |
| Division spacing: | approx. 20 mm |
| Tube diameter: | approx. 160 mm |
| Dimensions: | approx. 115 x 115 x 35 mm ³ |
| Weight: | approx. 820 g |
| 1019957 | \$1,504.00 |



Teltron® Discharge Tube S

Used for observing the phenomena occurring during electrical discharges in a gas in accordance with its pressure and type, cathode glow, positive column and canal rays. Either end of the discharge tube is equipped with a fluorescent screen. Demountable design, installation in tube holder (U185001). Includes a needle ventilation valve and vacuum hoses.

| | |
|-----------------------|------------------------|
| Length: | 280 mm |
| Polarization voltage: | $U \leq 5$ kV |
| Discharge current: | Typically $I = 1.2$ mA |
| Connections: | Via 4 mm-contact pins |

1000624 \$909.00

Additionally Required:

| | | |
|----------------------------------|----------------|-----------------|
| High-voltage power supply | 1003309 | \$658.00 |
| Vacuum Pump | 1003317 | \$488.00 |



A. Power Supply Unit for Franck-Hertz Experiment

Power supply unit for operating the mercury filled Franck-Hertz tube (P-1006795 resp. P-1006794), the neon filled Franck-Hertz tube (P-1000912) or the critical potential tubes (P-1000620 and P-1000621). The equipment provides all the voltages needed to power the tubes and includes a sensitive built-in DC amplifier for measuring collector current. The voltages can simultaneously be read off a display. The accelerating voltage can be set-up manually on the apparatus or set to a saw-tooth wave form. Additional measuring inputs are also available for the anode current and accelerating voltage.

Filament voltage U_F : 4 – 12 V, continuously adjustable
 Control voltage U_G : 0 – 12 V, continuously adjustable
 Accelerating voltage U_A : 0 – 80 V
 Modes of operation: manually adjusted / saw-tooth
 Countervoltage U_E : 0 – ± 12 V, continuously adjustable, switchable polarity

Output U_E for collector current I_E : $I_E = U_A * 38 \text{ nA/V}$ (0 – 12 V)

Output U_x for accelerating voltage U_A : $U_x = U_A / 10$

Outputs: 4 mm safety sockets

Input: BNC socket

Dimensions: approx. 160 x 132 x 210 mm³

Weight: approx. 3.4 kg

1012818 \$1,646.00

B. Franck-Hertz Tube with Neon Filling Mounted on Base

Used for demonstrating that free electrons colliding with neon atoms emit energy in quantized packets and for determining the excitation energy of the 3p0 or 3s1 states at about 19 eV. When excited, these states emit visible light due to the energy drop from intermediate levels to a ground state at an excitation energy of about 16.7 eV. The light emitted is in the red-yellow region of the spectrum. Bands of light develop between the control grid and the accelerating grid. The plane-parallel geometry of the grids means that these bands can be viewed through a window. Unlike the mercury-filled Franck-Hertz tube, the neon-filled version can be operated at room temperature. Tetrode with indirectly heated cathode, mesh control grid, mesh accelerating grid and collector (counter) electrode. Mounted on a base with color-coded connection sockets.

Filament voltage: 4 to 8 V AC/DC

Control potential: 9 V

Accelerating voltage: Max. 80 V

Countervoltage: 1.2 to 10 V DC

Tube: approx. 130 mm x 26 mm \varnothing

Base with connector sockets: 190 x 115 x 115 mm

Weight: approx. 450 g

1000912 \$790.00

Franck-Hertz Experiment

The quantization of energy and the generation, recording and evaluation of spectra, along with the experimental verification thereof, is included in most of the curricula used around the world. The well known experiment first performed by James Franck and Gustav Hertz in 1913 is critically important in terms of demonstrating discrete energy states in atoms.

C. Franck-Hertz Tube with Mercury Filling and Heating Chamber

Highly evacuated electron tube containing mercury in a heating chamber for demonstrating the discrete nature (quantization) of the energy released by free electrons in collisions with mercury atoms, and for determining the excitation energy of the mercury resonance line (61S0 – 63P1), which is 4.9 eV. The electron tube must be heated in the chamber to generate the necessary mercury vapour pressure to achieve a sufficiently high probability of collisions between electrons and mercury atoms. Electron tube with a plane parallel electrode system consisting of an indirectly heated oxide cathode with aperture, a grid and a collecting electrode. Front plate with printed tube symbol visible from a distance. Electric heating chamber with continuous temperature control and digital temperature display showing actual and set-point temperatures. In lacquered metal housing with two observation windows, opening with spring clip for thermometer, and thermally insulated carrying handle. Temperature measurement and control is handled by an integrated microcontroller and a Pt100 thermocouple.

Heater voltage: 4 – 12 V

Grid voltage: 0 – 70 V

Suppressor voltage: approx. 1.5 V

Tube dimensions: approx. 130 mm x 26 mm diam.

Heater output: 400 W

Temperature range: 160° C – 240° C

Temperature constancy: approx. $\pm 1^\circ$ C

Overall dimensions: approx. 335 x 180 x 165 mm³

Weight: approx. 5.6 kg

1006794 \$2,510.00

Additionally required:

Power Supply Unit (115 V, 50/60 Hz) 1012818 \$1,646.00

20 MHz Oscilloscope 3001445 \$738.00

Patch Cords 1002840 \$94.00

Patch Cord 1002746 \$20.00

Patch Cord, BNC/4mm Plug (need 2) 1002748 \$36.00

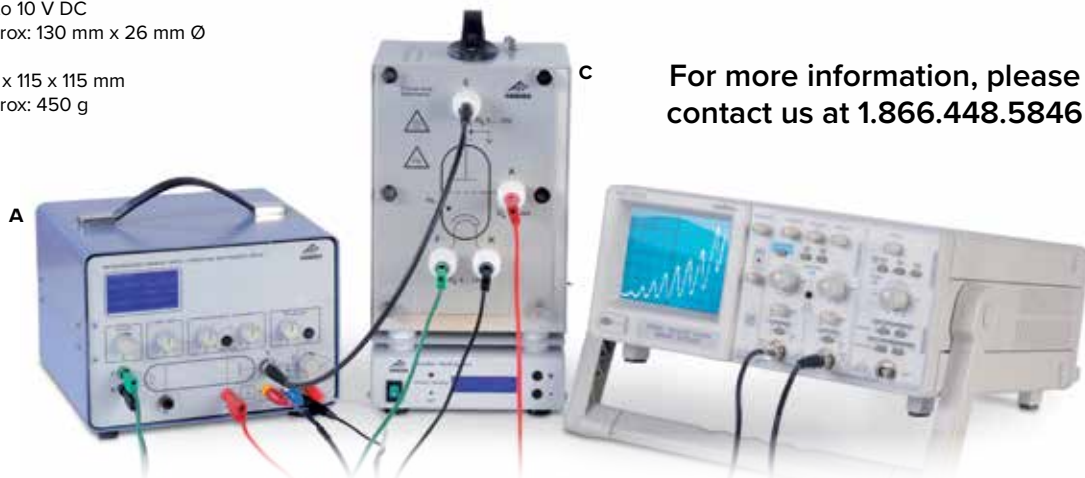

For more information, please contact us at 1.866.448.5846

Bundle & Save

Complete Kit:

- Franck-Hertz Tube with Neon
- Power Supply Unit
- 20 MHz Analog Oscilloscope
- Patch Cords

8000713 \$3,202.00

8000714 \$3,193.00

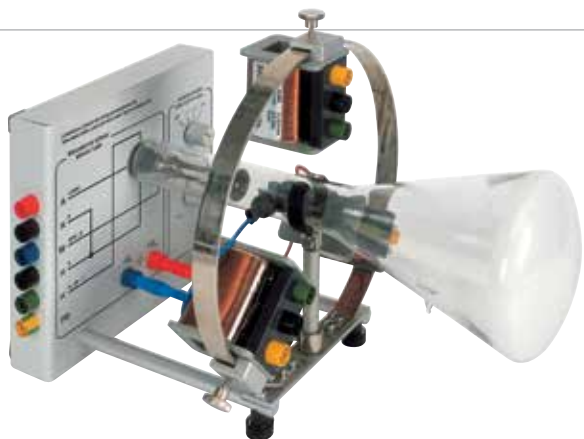

Training Oscilloscope

Used for investigating the design and operation of a cathode-ray tube. The electron beam can be deflected by an electric field produced by the deflection plates integrated into the tube, and by a magnetic field from three external coils mounted on a ring. A Wehnelt cylinder is used to focus the beam. A gas filling and fluorescent screen make it possible to observe the beam in the tube. A continuously adjustable saw-tooth generator can be used to analyze and visualize time-dependent processes. The device comes with a socket and printed wiring scheme.

| | |
|----------------------------------|--------------------------------------|
| Anode voltage: | 250 to 400 V DC |
| Anode current: | 1 mA |
| Filament voltage: | 6 to 8 V DC or AC |
| Filament current: | 0.3 A |
| Wehnelt voltage: | 0 to 50 V DC |
| Deflection plate dimensions: | 12x20 mm |
| Plate spacing: | 12 mm |
| Electric deflection sensitivity: | 0.2 mm/V |
| Screen diameter: | 100 mm |
| Tube length: | 260 mm |
| Residual gas: | Neon |
| coils: | 600 turns each, with a center pickup |
| Weight: | 1.6 kg |

1000902 \$1,391.00

Additionally Required:

| | | |
|------------------------------------|----------------|-----------------|
| Power Supply Unit, 500 V DC | 1003307 | \$724.00 |
| Function Generator | 1009956 | \$991.00 |
| AC/DC Power Supply | 1002775 | \$292.00 |
| Patch Cords | 1002843 | \$107.50 |

Replacement Item:

| | | |
|-------------------|----------------|-----------------|
| Spare Tube | 1000901 | \$731.00 |
|-------------------|----------------|-----------------|

System Components:

- Universal Computer Spectrometer with Software
- Complete scintillation probe with SD 38 detector, stand, base and cables
- Experimental Gamma Ray Spectroscopy manual

➤ Gamma ray spectroscopy and half-life studies



Isotope Generator

This C137/Ba-137 m Isotope Generator is used to demonstrate the properties of radioactive decay. Based on the original Union Carbide patented design, it offers exceptional performance, ease-of-use and safe operation.

Each generator contains 10 μCi of C137, which represents one Exempt Quantity, making it free from specific State and Federal licensing. The generator can produce up to 1000 small aliquotes of the short lived Ba-137m isotope with a half-life of 2.6 minutes.

Each generator is supplied with 250 ml of eluting solution (0.9% NaCl). The parent isotope C137 with a half-life of 30.1 years beta decays (94.6%) to the metastable state of Ba-137m.

This further decays by gamma emission (662 keV) with a half-life of 2.6 min. to the stable Ba-137 element. During elution, the Ba-137m is selectively "milked" from the generator, leaving behind the C137 parent. Regeneration of the Ba-137m occurs as the C137 continues to decay, re-establishing equilibrium in less than 1 hour.

Approximately 30 minutes after elution, the residual activity of the Ba-137m sample has decayed to less than one thousandth of its initial activity, making it safe for disposal. When used with the eluting solution supplied, bleed through of the parent C137 is less than 50 Bq/ml, affording a long working life. Each kit is supplied with the generator, syringe, tube, 250 ml of solution and a storage case.

3003908 \$250.00

Additionally Required:

| | | |
|-------------------------------------|----------------|----------------|
| 10mCi Extra Eluting Solution | 3003909 | \$15.00 |
| 250ml Bag of 100 planchets | 3003910 | \$26.00 |



Advanced Lab Spectroscopy System, PC only

Designed for conducting a wide selection of spectroscopy experiments, the Advanced Lab features the UC30 Universal Computer Spectrometer for IBM compatible computers. This external multi-channel analyzer connects through a USB port and includes a computer controlled amplifier, high voltage, 2048 channel MCA, upper and lower level discriminators and multi-channel scaling for half-life and decay studies. The complete system includes a Na(Tl) scintillation detector with lead shield and multi-position sample stand, a set of 8 gamma emitting radioisotope sources including an "unknown", MCA software with ISOMATCH peak identification and a lab manual of experiments in gamma spectroscopy. (Requires PC with minimum 512K memory, EGA/VGA/SVGA graphics, DOS or WINDOWS.)

3003907 \$3,940.00



> Nuclear physics made easy

Intermediate Nuclear Lab Station, PC or Mac

Our Intermediate Nuclear Lab System brings new dimensions to the study of Nuclear Science and radiation monitoring. By using a specialized microcontroller, many of the features previously found only in multiple products are now combined in a single inexpensive instrument. The classical nuclear scaler function has been extended to include a timer, preset counter, digital ratemeter with alarm, computer interface and optional battery power for field applications. The addition of preset count mode can be extremely useful when constant counting statistics are required, and the digital ratemeter is ideal for contamination survey work. The alarm level may be set to any pre-selected value and if the count rate exceeds this level, an audible alarm is sounded to warn of a high activity condition.

Valuable Components:

Also included is a set of 5 radioactive sources (U41512) containing 1 each of C137, Co-60, Sr-90, Tl-204 and Po-210, emitting a range of alpha, beta and gamma radiations. This set is ideal for demonstration and introductory nuclear labs covering basic characteristics of radiation. In addition, a set of 20 calibrated radiation absorbers (four lead, ten aluminum sheets, two polyethylene, two plastic, and two aluminum foil absorbers) covers the range from 4.5 to 7400 mg/cm² and consisting of aluminum plastic and lead plates is included. These absorbers are suitable for absorption studies with Alpha, Beta and Gamma radiation.

System Components:

- Radiation Counter with LABLINK software
- GM 35 probe with stand and cable
- USB cable for PC or Mac
- Set of five sources, Alpha, Beta, Gamma
- Set of 20 calibrated absorbers
- Student Lab manual
- Instructors manual

| | |
|----------------|---|
| GM Tube: | 25mm. diameter, 800V plateau, 2 mg/cm ² Window alpha sensitive |
| Sample Holder: | Ten position, 1 cm spacing |
| Display: | 6-decade. 2.5 cm LED, display counts, preset counts, time, preset time. CPM, CPS, alarm level, high voltage |
| Modes: | Preset time, preset count, CPM, CPS |
| High Voltage: | 0 to 1200V, digitally selected 25V increments |
| Power: | 9V DC from charger supplied |
| Absorbers: | 20 piece set |
| Sources: | Alpha as Po-210. Beta Sr-90, Tl-2M, gamma CO-BO, & C137 |
| Software: | Mac/PC |
| 3003905 | \$1,750.00 |

Basic Nuclear Lab Stations, PC

Designed for high school and junior college level nuclear science instruction, this system provides a complete solution for performing many basic nuclear demonstrations and experiments. The single convenient package includes a GM detector with multi-position sample stand, a 6-decade scaler with preset timer, a built-in 11-piece absorber set and a computer interface for optional connection to a PC computer.

The internal thin windowed 15mm Geiger Mueller counter allows detection of alpha, beta and gamma radiation.

Perform experiments such as:

- Range of Alpha Particles
- Absorption of Beta Particles
- Inverse Square Law
- Half-Life decay
- Detection Efficiency
- Counting Statistics
- Nuclear physics plus many additional laboratory exercises for both introductory and intermediate instruction

Powerful Software

By connecting the Basic Nuclear Lab Station to a PC, students can run experiments from a laboratory work station and display data directly on the computer screen. The software package supplied with the system stores each measurement in a data file which can be saved to disk for transferring into a spreadsheet for graphing and presentation.

System components:

- Nuclear Lab Station with NUCLAB software & set of 11 absorbers
- Serial cable for PC
- Set of three sources, Alpha Beta Gamma
- Student Lab Manual
- Instructors Manual

| | |
|----------------|---|
| GM counter: | 15mm diameter, 1.5-2 mg/cm ² window, 500V operating, 150V plateau |
| Sample holder: | 5-position, 1 cm spacing |
| Display: | 6-decade, 999999, 1.25 in. LED |
| Preset Time: | 0-900000 sec decade selection |
| High Voltage: | 0-800V, digital steps of 20V |
| Indicators: | Run, Set HV, Set Time |
| Serial Ports: | DB-9M for PC |
| Power: | 9V DC from unit (supplied) |
| Absorbers: | 11-piece set, 6-7400 mg/cm ² |
| Sources: | Po-210, Sr-90, Co-60 |
| Software: | PC |
| 3003904 | \$1,145.00 |



Set of Three Sources

Contains 1 each Po-210, Sr-90 and Co-60 emitting a range of alpha, beta and gamma radiations. This set is ideal for demonstration and introductory nuclear labs covering basic characteristics of radiation.

3003912 \$150.00

| Isotope | 1/2 Life | Activity | Emissions |
|---------|------------|--------------|-------------|
| Po-210 | 138 days | 0.1 μ Ci | Alpha |
| Sr-90 | 28.5 years | 0.1 μ Ci | Beta |
| Co-60 | 5.27 years | 1 μ Ci | Gamma, Beta |



Set of Five Sources

Containing 1 each C137, Co-60, Sr-90, Tl-204 and Po-210, this set provides a wide range of alpha, beta and gamma emissions making it a popular choice for nuclear science instruction. The set contains two beta emitters, two beta/gamma emitters and one alpha source for in-depth studies of radiation.

3003913 \$300.00

| Isotope | 1/2 Life | Activity | Emissions |
|---------|------------|--------------|-------------|
| C137 | 30.1 years | 1 μ Ci | Gamma, Beta |
| Co-60 | 5.27 years | 1 μ Ci | Gamma, Beta |
| Sr-90 | 28.5 years | 0.1 μ Ci | Beta |
| Tl-204 | 3.78 years | 1 μ Ci | Beta |
| Po-210 | 138 days | 0.1 μ Ci | Alpha |



GM Resolving Time Set

This set is used for determining the resolving time of GM Counters. It consists of three half discs, two of which contain 5 microcuries of Tl-204 plus a third half disc with no activity. The count-rate of each half disc plus the blank (to maintain constant geometry) is measured and then both active half discs are combined for a measurement with high count-rate.

The counting loss may now be calculated by adding the rates from each half disc and comparing the result to the count-rate with both halves combined.

3003911 \$200.00



Set of Eight Sources

Designed for gamma spectroscopy, with eight different gamma emitting isotopes covering the entire energy range from 32 to 1333 keV. Also included in the set is a mixed source of C137 and Zn-65 which students may use to identify an "unknown" isotope. The set consists of Ba-133, Cd-109, Co-57, Co-60, C137, Mn-54, Na-22 and Cs/Zn.

3003915 \$400.00

| Isotope | 1/2 Life | Activity | Emissions |
|---------|------------|------------|-------------|
| Ba-133 | 10.7 years | 1 μ Ci | Gamma |
| Cd-109 | 453 days | 1 μ Ci | Gamma |
| Co-57 | 270 days | 1 μ Ci | Gamma |
| Co-60 | 5.27 years | 1 μ Ci | Gamma, Beta |
| C137 | 30.1 years | 1 μ Ci | Gamma, Beta |
| Mn-54 | 312 days | 1 μ Ci | Gamma |
| Na-22 | 2.6 years | 1 μ Ci | Gamma |
| Cs/Zn | Mixed | 1 μ Ci | Unknown |

Individual Radioactive Sources

A variety of individual solid sources come in 1" or 1.75" diameter.

| Item Number | Isotope | 1/2 Life | Activity | Emissions | Price |
|----------------|---------|------------|--------------|---------------------------------------|-----------------|
| 3003923 | Ba-133S | 10.7 years | 1 mCi | Gamma | \$50.00 |
| 3003932 | C-14S | 5730 years | 10 mCi | Beta | \$160.00 |
| 3003924 | Cd-109S | 453 days | 1 mCi | Gamma | \$50.00 |
| 3003922 | Co-57 | 270 days | 1 μ Ci | Beta | \$50.00 |
| 3003920 | Co-60 | 5.27 years | 1 μ Ci | Gamma, Beta | \$50.00 |
| 3003927 | Cs/ZnS | Mixed | 1 mCi | Mixture of C137 and Zn-65 ("unknown") | \$50.00 |
| 3003921 | C137 | 30.1 years | 1 μ Ci | Gamma, Beta | \$50.00 |
| 3003925 | C137S.2 | 30.1 years | 0.2 mCi | Beta and Gamma | \$50.00 |
| 3003926 | C137S.5 | 30.1 years | 0.5 mCi | Beta and Gamma | \$50.00 |
| | C137S5 | 30.1 years | 5 mCi | Beta and Gamma | \$100.00 |
| 3003928 | Eu-152 | 13.5 years | 1 mCi | Gamma | \$100.00 |
| 3003933 | Fe-55S | 2.73 years | 100 mCi | Beta, X-ray | \$360.00 |
| 3003929 | Mn-54S | 312 days | 1 mCi | Gamma | \$50.00 |
| 3003930 | Na-22S | 2.6 years | 1 mCi | Gamma | \$50.00 |
| 3003917 | Po-210 | 138 days | 0.1 μ Ci | Alpha | \$50.00 |
| 3003918 | Sr-90 | 28.5 years | 0.1 μ Ci | Beta | \$50.00 |
| 3003919 | Tl-204 | 3.78 years | 1 μ Ci | Beta | \$50.00 |
| 3003931 | Zn-65S | 244 days | 1 mCi | Gamma | \$50.00 |



Steel Safe for Radioactive Materials

Steel safe for theft proof storage of radioactive materials in accordance with radiation protection requirements.

1000920 \$178.00

➤ Affordable and reliable power supplies

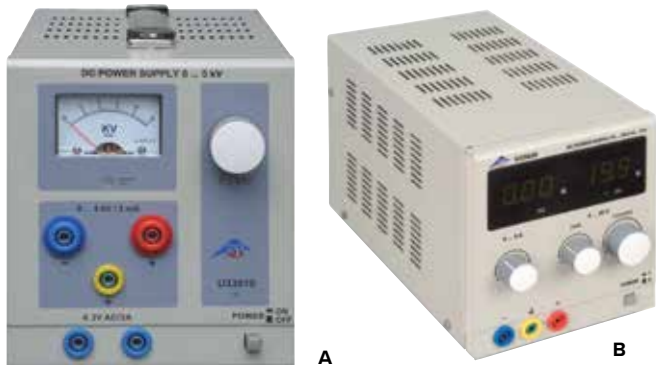

A. High Voltage Power Supply 5 kV

Universally applicable, floating, high-voltage source for operation of electron tubes. With built in high voltage resistant transformer to supply the heater voltage for electron tubes. Continuously adjustable high voltage, safe to touch, with passive current limitation and digital voltage display.

High voltage output: 0 – 5000 V DC, max. 2 mA
 Heater voltage output: 6.3 V AC, max. 3 A, high voltage resistant up to 6 kV

Connections: 4 mm safety sockets
 High-voltage display: 3 digit LED

1003309 \$658.00

B. DC Power Supply 0 – 20 V, 0 – 5 A

Universal power supply with digital current and voltage display. Output voltage and output current are continuously adjustable. The device can be used as a constant voltage source with current limiting or as a constant current source with voltage limiting.

DC output: 0 – 20 V, 0 – 5 A
 Output power: 100 W
 Stability under full load: $\leq 0.01\% \cdot 5 \text{ mV}$, $\leq 0.2\% \cdot 5 \text{ mA}$
 Residual ripple: $\leq 1 \text{ mV}$, 3 mA
 Display: 2 x 3 digit LED
 Terminals: 4 mm safety sockets
 Dimensions: approx. 130 x 150 x 300 mm
 Weight: approx. 4.7 kg

1003311 \$348.00



DC Power Supply 0 – 500 V

Low voltage power supply with four outputs primarily intended to supply power for electron tubes, including Helmholtz coils, with four independently adjustable DC voltages and analog dials for each of them. The DC voltages are stabilised and regulated, floating and galvanically isolated from one another, short circuit proof and secure from external voltages.

| | | |
|--------------------|---------------------------|----------------------------------|
| 500 V output: | Voltage: | 0 – 500 V DC, max. 50 mA |
| | Stability at full load: | $\leq 0.01\% \pm 100 \text{ mV}$ |
| | Residual ripple: | $\leq 20 \text{ mV}$ |
| 50 V output: | Voltage: | 0 – 50 V DC, max. 50 mA |
| | Stability at full load: | $\leq 0.1\% \pm 30 \text{ mV}$ |
| | Residual ripple: | $\leq 5 \text{ mV}$ |
| 8 V output: | Voltage: | 0 – 8 V DC, max. 3 A |
| | Residual ripple: | $\leq 0.1\% \pm 30 \text{ mV}$ |
| | Overload protection: | Thermal cut-out |
| 12 V output: | Voltage: | 0 – 12 V DC, max. 4 A |
| | Residual ripple: | $\leq 0.1\% \pm 30 \text{ mV}$ |
| | Overload protection: | Thermal cut-out |
| Displays: | Analog, class 2 | |
| Connections: | 4 mm safety sockets | |
| Power consumption: | 50 VA | |
| Dimensions: | approx. 85 x 325 x 190 mm | |
| Weight: | approx. 4 kg | |

1003307 \$724.00



Analog and Digital Triple Output DC Power Supply:

- Adjustable to 30V/3A with fixed 5V and 12V outputs
- Adjustable Voltage and Current output
- Easy snap terminals for fixed 5V/0.5A and 12V/1A outputs
- Constant Voltage or Current
- Current limiting indicator
- Overload and short circuit protection
- Binding post terminals for variable supply

| Item Number | A. 3004196 | B. 3004197 |
|----------------------------|---|---------------------------------|
| Price | \$179.99 | \$209.99 |
| Voltage Output | DC 0-30V | |
| Current Output, DC | 0 – 3 Amps | |
| Current Limiting Indicator | Status LED | |
| Accuracy | $\pm 7\%$ Full Scale | $\pm 1\%$ Full Scale • 2 digits |
| Ripple and Noise | < 5mV | |
| Line Regulation | < 0.05% • 10mV | |
| Fixed Output Voltage | 5V / 0.5A (continuous); 1A (max.) 12V / 0.5A (continuous); 1A (max.) | |
| Power | 110/220VAC 50/60Hz (switchable) | |
| Dimensions | 6 x 5.6 x 9.5" (152 x 142 x 242 mm) (W x H x D) | |
| Weight | 10 lbs. (4.5 kgs) | |



High Current DC Power Supply Unit, 16 V / 20 A

Digital display of voltage and current. The voltage and current are continuously adjustable by means of coarse and fine controllers. The device can be used as a constant-voltage source with current limiting, or a constant-current source with voltage limiting. The selected operating mode is indicated by an LED on the front panel. High reliability even under extremely adverse conditions is ensured by automatic transformer switchover, MOSFET power amplifiers and temperature-controlled fan speed with monitoring function. This equipment is also provided with a preset function for protecting against excess current and voltage. An interface socket is located on the front panel with inputs and outputs for external programming and monitoring by a PC. A USB-analog interface adapter is available on request. The design of the device omits any air vents at the top or bottom and does not require an external heat sink. The output is protected against sustained short-circuits. Two or more such units can be operated in series or in parallel.

Mains voltage: 115 V / 230 V, 50/60 Hz
 Output voltage: 0 – 16 V
 Fine-adjustment range: 800 mV
 Stability at 0 – 100% load: < 12 mV
 Residual ripple: < 1 mV
 Output current: 0 – 20 A
 Fine adjustment range: 2 A
 Connections: Via 4 mm jacks
 Dimensions: 240 x 120 x 300 mm
 Weight: 10 kg

1002771 \$1,228.00

Budget Power Supplies:

- Constant voltage or current
- Dual backlit LCD displays for voltage and current
- Short circuit protection
- Current limiting
- High load/line regulation
- Low noise/ripple
- Banana plug output terminals
- Complete with power cord



| Item Number | 3004159 | 3004160 |
|--------------------|--------------------------------|----------|
| Price | \$134.99 | \$144.99 |
| Display | Dual LCD, 3 Digits | |
| Display Accuracy | ±1.5% range V; ±2% range A | |
| Voltage Output, DC | 0-30V | 0-18V |
| Current Output, DC | 0-1A | 0-3A |
| Power | 110V/60Hz | |
| Warranty | 1 year | |
| Dimensions | 240 x 108 x 155 mm (W x H x D) | |
| Weight | 2 kg | 3 kg |

DC Power Supplies

- Light and compact design
- 0.01% high regulation
- Constant voltage and constant current operation
- Series or parallel operation function
- Remote control for external programmable
- Internal select for continuous or dynamic load
- Low ripple and noise
- Overload and reverse polarity protection



0-18V & 0-5A 3001453 \$306.00
0-30V & 0-3A 3001454 \$306.00

| | | |
|--------------|---|--|
| Meter | Digital | 3 digits 0.5" LED display Accuracy (0.5% of rdg • 2 digits) |
| Insulation | Chassis and Terminal Chassis and AC Cord | 20M or above (DC 500V) 30M or above (DC 500V) |
| Power Source | AC 100V/120V/220V/240V± 10%, 50/60Hz | |
| Accessories | Test lead x 1 Instruction manual x 1 Power cord x 1 | |
| Dimensions | 128 x 145 x 285 mm (W x H x L) | |



AC/DC Power Supply, 0 – 12V

Adjustable voltage power supply with illuminated analog display meter for stabilized and regulated DC output voltage, permanent electronic short-circuit protection and protection against interference voltages; additionally equipped with four electrically isolated AC voltage outputs. Overload protection via four overcurrent circuit breakers for increased lab safety.

DC output: 0 – 12 V, continuously adjustable
 Load capacity: 3 A, short-circuit proof
 Stability at full load: ≤ 20 mV
 Residual ripple at full load: ≤ 2 mVeff
 AC outputs: 3, 6, 9, 12 V
 Display: Analog, class 2.5
 Fuse: T 1.4, primary, 4 overcurrent circuit breaker, secondary

Connection voltage: 115 V, 50/60 Hz
 Connections: Via 4 mm safety jacks
 Dimensions: 23 x 11.5 x 19 cm
 Weight: 3.5 kg

1002775 \$292.00

➤ Compact size is great for student use



Power Function Generator

Sine and square wave generator especially well-suited for student and demonstration experiments. Illuminated, digital display for frequency and signal shape. Built-in amplifier is controlled with the volume knob. The output is short-circuit proof and protected against induction voltages and spark discharges; e.g. in the case of connected coils and accidental disconnection of the experiment cables when operated under load. Includes plug-in power supply.

Signal wave: Sine, square, positive square-wave
 Frequency range (1): 0.05 Hz - 3 kHz
 Resolution: 0.05 Hz
 Frequency range (2): 1 Hz - 50 kHz
 Resolution: 1 Hz
 Output voltage: 0 - ±12 V continuously adjustable, short-circuit proof
 Output current: Max. 1 A
 Connection: Via 4 mm-safety sockets
 Power consumption: Max. 15 VA
 Dimensions: 45 x 195 x 115 mm
 Weight: 1.2 kg

1009956 \$991.00



Color Digital Storage Oscilloscopes

Dimensions: 254 x 142 x 310 mm
 Weight: approx. 4.3 kg

Features:

- 200/100/60 MHz Bandwidth
- 2 or 4 Input channels
- 1GSa/s Real-time and 25GSa/s equivalent time sampling
- 25k Points record length maximum
- Large 5.6-in TFT color display
- USB Host/Device: Support USB printer and USB flash drive
- Color printout

2CH 60MHz 3001446 \$1,007.00
2CH 100MHz 3001447 \$1,758.00
2CH 200MHz 3001448 \$2,502.00
4CH 200MHz 3001449 \$3,018.00

➤ Complete your lab with easy-to-use oscilloscopes from 3B Scientific!

A. 20MHz Analog Oscilloscope Function Generator

The general purpose analog oscilloscope with a 20MHz bandwidth. Aside from the basic functions, such as 1mV/div~5V vertical sensitivity, 0.2uS/div~0.5S/div horizontal sweep time, and practical Auto/Norm/TV-V/TV-H trigger modes, the GO620FG offers extra function generating features required for most class experiments and electrical production lines. The affordably priced GO620FG is capable of generating Sine/Square/Triangle waveforms in the frequency ranges from 0.1Hz~1MHz (7 range) with sine wave distortion as low as 2%.

3001460 \$794.00

CRT: 6-inch rectangular type with internal graticule 8x10 DIV
 Power Source: AC 100V/120V/220V/230V
 • 10%, 50/60Hz
 Accessories: Power cord, instruction manual, Probes (10:1/1:1)
 Dimensions: 310 x 150 x 455 mm
 Weight: approx. 8.2 kg

B. 20 MHz Analog Oscilloscope

Features:

- 20 MHz, dual channel
- High sensitivity 1mV/Div
- TV synchronization
- A axis input
- ALT triggering function
- Hold off function
- CH1 output

3001445 \$738.00





> NEW

Digital Oscilloscope 2x100 MHz

Latest generation, dual-channel digital storage oscilloscope for many applications with the following features:

- High-resolution colour display and back-lighting
- Large internal data memory
- VGA output for connecting external monitor
- LAN connection for remote access via network
- USB port for real-time data transmission or for reading internal memory
- Autoset and autoscale functions for user-friendly operation
- 20 automatic measuring modes plus FFT function
- PASS/FAIL function

Includes two probes, two BNC cables, USB connecting cable, and software CD for Windows 2000/XP/VISTA/7/8/10.

| | |
|-------------------------|---|
| Channels: | Two |
| Band width: | 100 MHz |
| Sample rate: | Dual CH 500 MS/s Single CH 1 GS/s |
| Operating modes: | CH1, CH2, XY |
| Input: | |
| Input coupling: | DC, AC, GND |
| Input impedance: | 1 M Ω \pm 2% 10 pF \pm 5 pF |
| Input voltage: | 0 – 400 V DC or ACpp |
| Vertical: | |
| Deflection coefficient: | 2 mV/div. – 10 V/div. |
| Precision: | \pm 3% |
| A/D converter: | 8-bit resolution |
| Horizontal: | |
| Time-base coefficient: | 2 ns/div. – 100 s/div. |
| Sampling range: | 0.5 S/s – 250 MS/s |
| Precision: | 100 ppm |



Measuring mode:
Automatic measurement: Vpp, Vmax, Vmin, Vtop, Vbase, Vamp, Vavg, Vrms, overshoot, pre-shoot, rise time, fall time, +width, -width, +duty, -duty, delay A-B (rising), delay A-B (falling), freq, period, FFT
+, -, *, /, FFT

Maths functions:
Trigger:
Trigger type: Edge, Video, Pulse, Slope
Trigger modes: Auto, Normal, Single
Trigger detection: Sample, peak detect, average

Interfaces:
Memory size: 10000 measurements
Interface: USB 2.0, VGA, LAN
Power supply: 100 – 240 V, 50/60 Hz

General data:
Display: TFT colour screen, 8 inches, 800 x 600 pixels, 65536 colours
approx. 340 x 155 x 70 mm³
approx. 1.8 kg

1020911 \$1,020.00

Microvoltmeter

Used for the measurement and amplification of extremely small DC and AC voltages e.g. induction, thermo- and photovoltages. Indication using LED display, in addition a voltage signal proportional to the measurement variable can be tapped at the analog output and supplied to a demonstration measuring instrument, a recorder or an interface.



The measurement signal is fed into the device via a BNC socket or a 4-mm safety socket. An additional DIN socket allows for the connection of Hall sensors. A filter can be connected to the measurement input for signal smoothing or for upper limitation of the measurement frequency.

Measurement ranges (199.9 μ V; 1.999 mV; 19.99 mV; 199.9 mV; AC/DC)

Frequency range for AC: 10 Hz up to 1 kHz
Input impedance: DC range: 100 k Ω ; AC range: 900 k Ω
Upper cutoff frequency: 1 Hz; 10 Hz; 100 Hz; 1 kHz (switchable)
also usable for DC-signal smoothing

Display: 3digit LED, 20 mm high

Measurement accuracy: 5%

Measurement rate: 3 measurements/s

Output voltage: 0 up to \pm 2 V

Output current: Max. 1 mA

Dimensions: 235 x 250 x 180 mm

Weight: Approximately 3.3 kg

1001015 \$2,000.00

Benchtop Digital Multimeter

This benchtop digital multimeter provides a wide range of capabilities at a value price. Feature rich and high performance, it is the ideal solution for your testing stations. Measure AC/DC voltage and current, resistance, capacitance and test diodes (max 2.5 mA/ 3.2 V). Includes a continuity beeper if the conductance is less than 30 Ω as well as a 0.5" LCD display. Comes with instruction manual, power cord and test lead.

245 x 95 x 280 mm; 2 kg

3001455 \$285.00



| | |
|--------------|--|
| DC Voltage: | Range: 200mV, 2V, 20V, 200V, 1000V 5 ranges, Accuracy: \pm (0.5% rdg + 1 digit), Input Impedance: 10M Ω |
| AC Voltage: | Range: 200mV, 2V, 20V, 200V, 750V 5 ranges, Accuracy: 40Hz~500Hz \pm (0.5% rdg + 1 digit), Input Impedance: 10M Ω |
| DC Current: | Range: 200 μ A, 2mA, 20mA, 200mA, 2A, 20A 6 ranges, Accuracy: 200 μ A ~ 2mA \pm (0.5% rdg + 1 digit) 2A ~ 20A \pm (0.5% rdg + 3 digits) |
| AC Current: | Range: 200 μ A, 2mA, 20mA, 200mA, 2A, 20A 6 ranges Accuracy: 40Hz ~ 500Hz on all ranges, 200 μ A ~ 2mA \pm (1.0% rdg + 3 digits), 2A ~ 20A \pm (1.5% rdg + 2 digits) |
| Resistance: | Range: 200 Ω , 2k Ω , 20k Ω , 200k Ω , 2M Ω , 20M Ω 6 ranges Accuracy: 20M Ω \pm (1.5% rdg + 5 digits) |
| Capacitance: | Range: 2nF, 20nF, 200nF, 2 μ F, 20 μ F 5 ranges Accuracy: \pm (1.5% rdg + 5 digits) Test Frequency: 300Hz \pm 5% |



> NEW

PC-Oscilloscope 2x25 MHz

Advantages:

- Greatest possible safety for users and computer systems thanks to galvanically isolated USB interface
- Mathematical functions +, -, *, /, inversion and FFT implemented
- 20 automatic measurement modes
- Powerful PC software for acquisition of data and for control

Dual-channel PC oscilloscope for connection to a computer via USB ports. Includes isolated USB interface allowing a maximum input voltage of 400 V via the USB port. By connecting the equipment to a PC, you obtain an extensively equipped digital storage oscilloscope with the additional advantage that the measurement data is saved and can, for example, be further analyzed using fast Fourier transform (FFT) analysis.

Includes two probes (1:1, 10:1), a USB connecting cable, two BNC cables, operating instructions and software CD for Windows® XP/Vista/7/8.

1020857 \$301.00

| | |
|-------------------------------------|---|
| Channels: | Two |
| Band width: | 25 MHz |
| Sample rate per channel: | 100 MS/s |
| Operating modes: | CH1, CH2, XY |
| Input: | |
| Input coupling: | DC, AC, GND |
| Input impedance: | 1 MΩ ±2% 10 pF ±5 pF |
| Input voltage: | 0 – 400 V DC or ACpp |
| Multi-input: | Sync., in/out, pass/fail, ext. trigger |
| Vertical: | |
| Deflection coefficient: | 2 mV/div. – 50 V/div. |
| Precision: | ± 3% |
| A/D converter: | 8-bit resolution |
| Horizontal: | |
| Time-base coefficient: | 5 ns/div. – 100 s/div. |
| Sampling range: | 0.5 S/s – 200 MS/s |
| Precision: | 100 ppm x reading • 0.6 ns |
| Automatic measurement: | Vpp, Vmax, Vmin, Vtop, Vbase, Vamp, Vavg, Vrms, overshoot, pre-shoot, rise time, fall time, +width, -width, +duty, -duty, delay A-B (rising), delay A-B (falling) |
| Maths functions: | +, -, *, /, inversion, FFT |
| Trigger type: | Alternate, Edge, Video, Pulse, Slope |
| Trigger modes: | Auto, Normal, Single |
| Trigger detection: | Sample, peak detect, average |
| Memory size: | 5000 measurements |
| Interface: | USB 2.0 |
| Power supply: | 5 V DC via two USB ports |
| Software: | Windows® - XP/Vista/7/8 |
| Data export for further assessment: | Formats: bin, txt, csv or xls |
| Image file for current screen: | Formats: png, bmp or gif |
| Dimensions: | approx. 170 x 120 x 18 mm ³ |
| Weight: | approx. 260 g |

> NEW

Digital Multimeter E

Compact 3½-digit multimeter for measuring voltage, current and resistance as well as for diode and hFE gain testing. All measurement ranges are selected by means of a rotary dial. All measurement ranges are protected against overload. Includes measuring leads and battery.

| | |
|--------------------|--|
| DC voltage: | 2 V – 600 V, 4 ranges, ±0.8% ±5 digits |
| AC voltage: | 2 V – 600 V, 4 ranges, ±1% ±5 digits |
| DC current: | 20 µA – 10 A, 7 ranges, ±1.8% ±2 digits |
| AC current: | 20 µA – 10 A, 7 ranges, ±2% ±3 digits |
| Resistance: | 200 Ω – 200 MΩ, 7 ranges, ±1% ±4 digits |
| Display: | 3½- display LCD, 24 mm, max. 1999 |
| Operating voltage: | 9 V battery 6F22 |
| Fuse: | F1: F 2 A / 600 V F2: F 10 A / 600 V, I _{max} = 10 A for 10 s with minimum interval 15 mins |
| Dimensions: | approx. 90 x 190 x 35 mm ³ |
| Weight: | approx. 310 g (with battery) |

1018832 \$40.00



Analogue Multimeter ESCOLA 100

Meter for classroom and practical experiments to measure voltage and current up to 600 V or 10 A respectively. Also features audible continuity testing. Includes a fuse to guarantee safety up to CAT III. The separate terminal sockets for current and voltage permit connection of the instrument that allows for current as well as voltage to be measured without having to reconnect the measuring leads. When switching from one measuring range to another, the circuit is never broken. All current measuring ranges are overload-proof for long-term current of up to 10 A. The protection of all current measuring ranges by means of additional semiconductor protection prevents inadvertent blowing of the fuse in many cases.

| | |
|---------------------------------|--|
| Direct and alternating voltage: | 0.1 – 600 V, 9 ranges each |
| Direct and alternating current: | 0.1 mA – 3000 mA, 11 ranges each |
| Internal resistance: | 1 MW |
| Long term maximum voltage: | 600 V |
| Instrument category: | CAT III, 600 V (DIN EN 61010-1:2010, 61010-2-033:2012) |

1013527 \$268.00





Three new Multimeters include all the features you need and want.

Item U40165 measures AC/DC voltage, AC/DC current, resistance, diode test, and continuity plus thermocouple temperature. The U40166 adds capacitance, frequency, and duty cycle to the range of measurements possible. For true versatility choose the U41067, all the above measurements plus thermocouple and non-contact IR temperature. Each unit comes with an operations manual detailing features and measurement settings.

➤ **These multimeters pay you back with reliable high performance every day. Don't settle for inferior quality!**

| Item Number | A. 3004188 | B. 3004189 | C. 3004190 |
|-----------------------------------|---------------------------------------|-----------------------|----------------------------|
| Price | \$49.99 | \$94.99 | \$149.99 |
| Display Counter | 2000 Counts Backlit | 4000 Counts Backlit | |
| True RMS | — | Yes | |
| Basic Accuracy | ±0.5% (VDC) | ±0.3% (VDC) | |
| DC/AC Voltage | 0.1mV to 600V (DC) / 1mV to 600V (AC) | 0.1mV to 600V (DC/AC) | |
| DC/AC Current | 0.1µA to 20A | | |
| Resistance | 0.1Ω to 20MΩ | 0.1Ω to 40MΩ | |
| Capacitance | — | 0.01nF to 100µF | |
| Frequency | — | 0.001Hz to 10MHZ | |
| Temperature (Type K) | -4 to 1382° F (-20 to 750°C) | | |
| Temperature (Infrared with Laser) | — | — | -4 to 518°F (-20 to 270°C) |
| Duty Cycle | — | 0.1 to 99.9% | 0.1 to 99.9% |
| Diode/Continuity | Yes | | |
| CE/UL Category Rating | CE/UL CAT III | CE/UL CAT III-600V | |
| Dimensions | 7.4 x 3.2 x 2" (187 x 81 x 50mm) | | |
| Weight | 0.75lbs (342g) | | |
| Warranty | 1 year | 3 year | |



Analogue Multimeter ESCOLA 30

Permanently short-circuit-proof student measuring instrument for measuring voltage and current in the safety extra-low voltage range. The electronic overload protection is achieved without the use of an equipment fuse, therefore obviating any need to change fuses or order spares. The protective system nevertheless operates without any auxiliary energy and is guaranteed even when the battery is flat or no battery is present.

Direct and alternating voltage: 0.3 – 30 V, 5 ranges each
 Direct and alternating current: 1 – 3000 mA, 5 ranges each
 Instrument category: CAT I, 30 V

1013526 \$212.00

Digital Mini MultiMeters

Compact and versatile multimeters include thermocouple and are available in manual ranging or autoranging.

Includes:

- Protective rubber holster, battery, test leads and Type K thermocouple probe
- Large easy to read digital display
- Measure DC current to 10A
- Thermocouple temperature measurements to 1400°F (750°C)
- Resistance tests with Continuity and Diode functions
- Autoranging models capable of AC Current, Capacitance, and Frequency measurements
- Convenient mini size with protective rubber holster and tilt stand
- Data Hold locks reading into the display



| Item Number | 3004163 | Manual Ranging | 3004164 | Autoranging | | |
|--------------|-----------------------------|-----------------|----------------|---------------------------------------|-----------------|----------------|
| Price | \$19.99 | | \$39.99 | | | |
| Functions | Range | Max. Resolution | Basic Accuracy | Range | Max. Resolution | Basic Accuracy |
| DC Voltage | 200mV, 2V, 20V, 200V, 600V | 0.1mV | ±0.5% | 400mV, 4V, 40V, 400V, 600V | 0.1mV | ±0.5% |
| AC Voltage | 200V, 600V | 0.1V | ±1.2% | 4V, 40V, 400V, 600V | 0.1V | ±1.2% |
| DC Current | 200mA, 10A | 0.1mA | ±1.5% | 400µA, 4000µA, 40mA, 200mA, 10A | 0.1µA | ±1.2% |
| AC Current | — | — | — | 400µA, 4000µA, 40mA, 200mA, 10A | 0.1µA | ±1.5% |
| Resistance | 200Ω, 2kΩ, 200kΩ, 20MΩ | 0.1µΩ | ±0.8% | 400Ω, 4kΩ, 40kΩ, 400kΩ, 4MΩ, 40MΩ | 0.1Ω | ±1.2% |
| Capacitance | — | — | — | 4nF, 40nF, 400nF, 40µF, 100µF | 0.001nF | ±3.0% |
| Frequency | — | — | — | 10Hz, 100Hz, 1kHz, 100kHz, 1MHz, 5MHz | 0.01Hz | ±1.0% |
| Temperature | -4 to 1400°F (-20 to 750°C) | 1° | ±(1%+4°) | -4 to 1400°F (-20 to 750°C) | 1° | ±(1%+4°) |
| Battery Test | 9V and 1.5V Batteries | | | — | | |
| Power | One 9V Battery | | | 2 x AAA Batteries | | |
| Dimensions | 138 x 72 x 38 mm | | | | | |



LCR Meter

Measures inductance, capacitance, and resistance. This meter will accurately measure capacitors, inductors and resistors using the test frequencies of 120Hz and 1kHz. The dual display will simultaneously display the associated quality factor, dissipation or resistance value using a series or parallel equivalent circuit.

Features:

- Simultaneous 20,000/10,000 count display of the primary parameter (L, C, or R) with the secondary parameter of Q (quality), D (dissipation) or R (resistance)
- Set Hi/Lo limits using absolute values or percentage
- Parallel or series equivalent circuit
- 4-1/2 digit backlight LCD display
- Max/Min/ Avg recording, Auto power off
- Automatic blown fuse indication
- Built-in test fixture or use external test leads
- Open and short Zero removes unwanted stray impedances from the measurement
- Relative mode with zero reference or user supplied reference
- CE approved, one year warranty
- Complete with test leads, alligator clips, 9V battery, and protective holster

3004095 \$257.00

Zero-Point Galvanometer CA 403

Reasonably priced, sturdy and easy-to-use analog measuring instrument with moving coil instrument and rectifier, particularly well-suited for student and practical experiments, may be used as a DC microammeter and DC millivoltmeter. This device has only one control knob, includes safety sockets and quick-break fuses, is electrically protected and double-insulated.



Specifications:

Meas. ranges: 100 mV DC, 30 μ A DC, 3 mA DC
 Int. resistance: 3333 Ω , 460 Ω , 500 Ω
 Accuracy: $\pm 1.5\%$
 Zero point: center
 Mirrored scale: yes
 Connection: 4 mm-security sockets
 Fuse: 0.315 A HBC 380 V 50 kA
 Dimensions: 165 x 105 x 50 mm
 Weight: 450 g

1002726 \$567.00



Resistance Decade, 1 Ω up to 10 k Ω

Four resistance decades in a single housing, can be used individually or in combination, e.g. for setting up a Wheatstone bridge. Can be set using control knob, with decade scale.

1002735 \$176.00

Analog Voltmeter

Range: 0-3 V, 0-15 V, 0-30 V

3007430 \$9.90



Inductance Decade

Housing made of shock-resistant ABS plastic. This series incorporates mechanically stable components, a slide switch for setting measurement ranges and colored, 4 mm sockets with clips for connecting wires.

1002796 \$304.00



Resistance Decade

Easy slide switch design allows quick adding and subtracting of resistor values. Unit also offers any resistor value between 1 Ω and 11M Ω . Equipped with insulated plug sockets for safe operation.

3004205 \$109.99



Capacitance Decade

Intuitive system of switches makes creating capacitance values between 100pF and 11MF almost too easy. Protected 4 mm plugs always promotes safe laboratory experiments.

3004206 \$139.99

➤ **Patch Cords:** All Patch Cords are equipped at either end with a laminated plug and a fully-insulated axial jack for connecting additional patch cords.

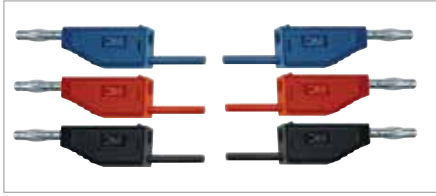

Set of 15 Low Volt Patch Cords, 75 cm

Used for low-voltage electrical circuits; copper wire encased in highly flexible PVC.

Wire cross-section: 1 mm²
 Continuous current: max. 19 A
 Plug and jack: 4 mm Δ (nickel-plated)

1002840 \$94.00

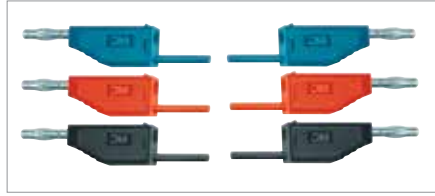

Set of 15 Patch Cords, 75 cm

Used for electrical circuits with low voltages and high currents; copper wire encased in highly flexible PVC.

Wire cross-section: 2.5 mm²
 Continuous current: max. 32 A
 Plug and jack: 4 mm Δ (nickel-plated)

1002841 \$104.00

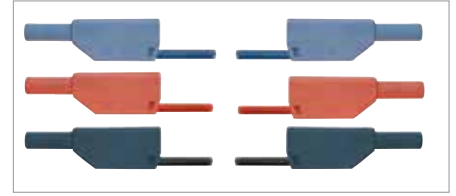

Set of 15 Safety Patch Cords, 75 cm

Used for electrical circuits with low voltages and high currents; copper wire encased in highly flexible PVC; equipped at either end with a laminated safety plug and a fully-insulated axial jack for connecting additional patch cords.

Wire cross-section: 2.5 mm²
 Continuous current: max. 32 A
 Plug and jack: 4 mm Δ (nickel-plated)

1002843 \$107.50

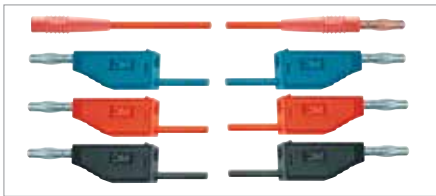

Set of 17 Patch Cords

Seventeen maximum-quality patch cords with 4 mm-connectors for all cabling between tubes, power supplies, display units and coils. (see page 207 for quantities)

Wire cross-section: 1 mm²
 Continuous current: max. 19 A
 Plug and jack: 4 mm (nickel-plated)

1002847 \$115.00

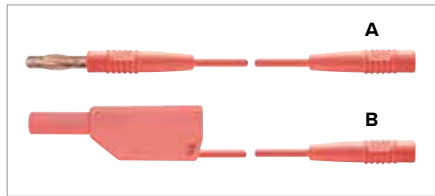

Safety Patch Cords

Patch cord with Multilam plug / jack

Length: 75 cm
 Wire cross-section: 1 mm²
 Continuous current: max. 19 A
 Color: red
 Plug and jack: 4 mm

A. Gold Plated 1002838 \$6.88
B. Nickel Plated 1002839 \$6.88



High-frequency Patch Cords

Shielded patch cords for low-loss, low-capacitance transmission of high-frequency signals; equipped at either end with a BNC plug. Impedance: 50 W

1002746 \$20.00

High-frequency Patch Cord (not shown)

BNC / 4-mm plug. Shielded patch cord equipped with a BNC plug at one end and a 4-mm plug at the other end.

1002748 \$36.00



BNC Patch Cord Connector

Equipped at either end with a BNC jack for connecting high-frequency patch cords with BNC plugs.

1002749 \$3.00

Adapter

BNC jack / 4 mm-plugs. Adapter for crossover from a BNC jack to 4 mm-plugs with 19 mm spacing.

1002751 \$13.00

Adapter

BNC jack / 4 mm-jacks. Adapter for crossover from a BNC plug to 4 mm-jacks.

1002750 \$9.00

T-piece, BNC

For connecting two high-frequency patch cords to one BNC jack.

1002752 \$5.00



Crocodile Clip 4 mm, Pack of 15

Non-insulated test clip with 4-mm sockets for accepting 4 mm-test leads or any other 4 mm-Multilam plug. Connection also possible with screw clamp or soldering.

3004565 \$7.00



Precision Mass Set, 12 pieces
 Extreme accuracy makes this an excellent choice for precision calibration and weighing. Weights: 1-500 g, 2-200 g, 1-100 g, 1-50 g, 2-20 g, 1-10 g, 1-5 g, 2-2 g, 1-1 g
3002736 \$90.00



Slotted Weight Set with Hanger
 1-50 g (hanger), 9-20 g, 1-10 g, 2-5 g
3001290 \$16.49

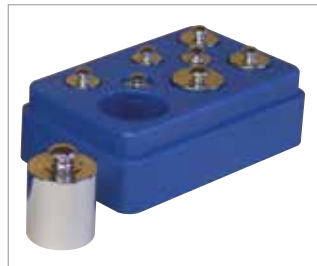

Precision Mass Set, 8 pieces
 Housed in plastic casing. 1-50 g, 1-20 g, 2-10 g, 1-5 g, 2-2 g, 1-1 g
3001291 \$9.25



Set of Weights 1 g to 500 g
 12-piece set of brass weights on convenient storage rack. 1-1 g, 2-2 g, 1-5 g, 1-10 g, 2-20 g, 1-50g, 1-100 g, 2-200 g, 1-500 g
1018597 \$117.00



Set of Weights 10 g to 1000 g
 9-piece set of brass weights in storage box, each with hooks on both sides. 1-10 g, 2-20 g, 1-50 g, 1-100 g, 2-200 g, 1-500 g, 1-1000 g
1003214 \$290.00



Set of Weights, 1 g to 1000 g
 13-piece set of brass weights in storage block. 1-1 g, 2-2 g, 1-5 g, 1-10 g, 2-20 g, 1-50 g, 1-100 g, 2-200 g, 1-500 g, 1-1000 g
1003212 \$207.00



Weight Holder, 50 g
 Weight holder for weight set U30013.
1003215 \$8.00

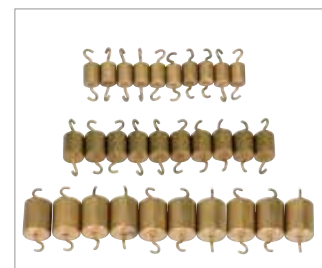

Set of 10 Weights
 Brass weights with hooks on both sides so that they can be suspended from one another.
10 g 1000770 \$47.00
20 g 1000769 \$53.00



Precision Dynamometer, Transparent
 Color-coded precision dynamometer in a transparent plastic casing with easy-to-read scale, protection against over-extension of the spring and zero-point calibration capability.
 Precision: < 1% of maximum measurement
 Dimensions: 280 x 16 mm Ø



Dynamometer, Color Coded
 Color coded dynamometer for measuring weights or masses as well as forces. Scaled in newtons or grams and kilograms with zero-point calibration.

➤ Buy 20 and get 25% off!

| Item Number | Color | Range | Scale division | Price |
|-------------|--------|-------|----------------|---------|
| 1003102 | Silver | 0.1 N | 0.001 N | \$27.00 |
| 1003103 | Beige | 0.2 N | 0.002 N | \$27.00 |
| 1003104 | Yellow | 1 N | 0.01 N | \$27.00 |
| 1003105 | Red | 2 N | 0.02 N | \$27.00 |
| 1003106 | Blue | 5 N | 0.05 N | \$27.00 |
| 1003107 | Green | 10 N | 0.1 N | \$27.00 |
| 1003108 | Violet | 20 N | 0.2 N | \$27.00 |

➤ Buy 10 and SAVE more than 35%!

| Item Number | Color | Range | Scale division | Price |
|-------------|--------|---------------|----------------|--------|
| 1003370 | Blue | 250 g / 2.5 N | 5 g / 0.05 N | \$8.00 |
| 1003371 | Green | 500 g / 5 N | 10 g / 0.1 N | \$8.00 |
| 1003372 | Brown | 1000 g / 10 N | 20 g / 0.2 N | \$8.00 |
| 1003373 | Red | 2000 g / 20 N | 50 g / 0.5 N | \$2.99 |
| 1003374 | White | 3000 g / 30 N | 50 g / 0.5 N | \$3.00 |
| 1003375 | Yellow | 5000 g / 50 N | 100 g / 1 N | \$2.99 |



Precision Measurement Set, 4 pieces

All the basics for taking precise length measurements.

Includes:

- 1-Micrometer 25 x 0.1 mm
- 1-Vernier Caliper 150 x .05 mm (6 x .001 in)
- 1-Knife edge square 90 degree
- 1-Ruler Steel 150 mm (6 in) housed in a sturdy case

3001289 \$68.00

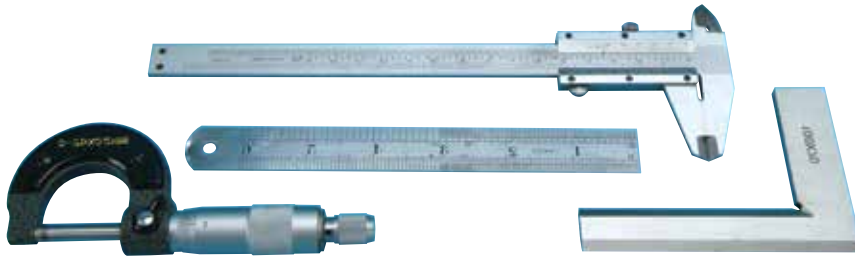

Callipers, 150 mm

Precision callipers for measuring internal and external dimensions and depth. Tempered stainless steel, precision polished measuring surfaces, gauge with matte-chrome finish. In imitation leather pouch.

Measuring range: 150 mm / 6 inch
 Graduation: 1/20 mm / 1/128 inch

1002601 \$34.00

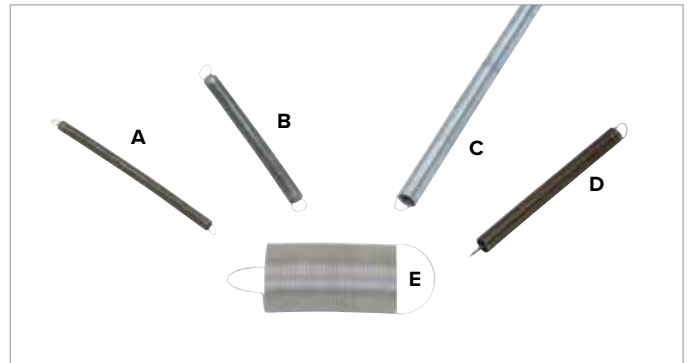

| Item Number | Constant N/m | Max Load | Length | Price |
|-------------------|--------------|----------|--------|----------------|
| A. 1002704 | 20 | 6.5 | 110 mm | \$10.00 |
| B. 1002946 | 30 | 13.5 | 115 mm | \$13.00 |
| C. 1002703 | 6 | 2.5 | 115 mm | \$10.00 |
| D. 1002702 | 3 | 1.5 | 80 mm | \$10.00 |
| E. 1002945 | 20 | 8.0 | 180 mm | \$10.00 |



Universal Spirit Level, 250 mm

Spirit level made of shock-resistant plastic for measuring angles to horizontal, vertical and inclined planes. The rotating gauge can be turned and fixed in place when measuring inclined planes. Gauges are designed to prevent leakage and breaking. Scale markings: 45°, 60° and 120°; mm scale on measuring surface; protractor scale for rotating gauge.

Scales: 250 mm/1 mm, -90° to +90°/2°
 Dimensions: 250 x 54 x 15 mm

1002604 \$36.00



Demonstration Model of Vernier Scale

Demonstrate Vernier reading on numerous length and angle measuring instruments. With retrograde and direct Vernier graduation.

Length: 60 cm
 Length of Nonius: 26 cm
 Height: 19 cm

1002951 \$77.00



Plumb Line

Brass body on a line.
 Height: 100 mm
 Diameter: 20 mm
 Weight: 220 g
 Line length: 1600 mm

1002940 \$26.00



Mini Thermo-Anemometer • Humidity

Waterproof pocket size with air velocity, temperature, %RH, dew point and windchill. Display air velocity and either relative humidity, dew point, temperature or windchill. Selectable averaging function of 5, 10, or 13 second intervals. Fold up protective housing extends to 9" (229 mm) for better reach, tripod mount. Data hold with auto power off. Water resistant housing floats.

3004201 \$154.99

Heat Stopwatch

- Selectable Heat Index alarm
 - Stopwatch/chronograph mode with 1/100 second resolution
 - Fastest/Slowest/Average Lap recall
 - 99 lap counter with 30 lap/split memory
 - 10 hour countdown timer with audible beeper warning
 - Programmable alarm
 - Calendar mode displays day, month and date
 - Battery included (CR2032)
- Dimensions: 3.1 x 2.6 x 0.8"
Weight: 3 oz. with battery

3004203 \$44.99



A. Set of Riders for Rulers

The set of riders consists of two red plastic pointers to match rulers U8401550 and U8401560 that can be used as movable cursors. 120 x 40 x 20 mm

1006494 \$53.00

B. Vertical Ruler, 1 m

Ruler with fastening pin (d = 12 mm) so that it can be set up vertically in a stand base. Scale as per 1000742.

1000743 \$57.00

Mechanical Cumulative Stopwatch

Cumulative stopwatch with start, stop and reset buttons in shock-resistant plastic casing.

Dual dial for minutes and seconds; pendant cord.

Measuring range: 15 min; accurate to within 1/10 sec.

Unit diameter: 55 mm.

1002810 \$114.00



Digital Stopwatch

Stopwatch with start/stop and split/reset buttons for starting and stopping, cumulative, lap-time and dual-time measurement.

Measuring range: 9 h, 59 min, 59 sec, 99/100 sec. Accurate to within 1/100 sec. 65 x 65 x 18 mm.

1002811 \$36.00



Analog Barometer

This wall mountable barometer will allow you to predict tomorrow's weather or check the ambient pressure before starting your experiment. A brass housing and classic design make the barometer usable in a lab or at home.

Range: 27.5 to 31.5 (940 to 1060 mbar) in HG

Dimensions: 4.5" dial diameter, 5" overall

Weight: 10 oz

3002974 \$46.00



Precision Hair Hygrometer

For measuring the relative air humidity, consisting of a round plastic housing with a human hair as the measuring element. The specially treated hair exhibits an almost inertia-free response to changes in humidity. Wall-mountable.

Measuring range: 0% - 100% relative humidity

Temperature range: -35°C - +65°C

Reading accuracy: ± 5%

Diameter: 100 mm

1002877 \$53.00



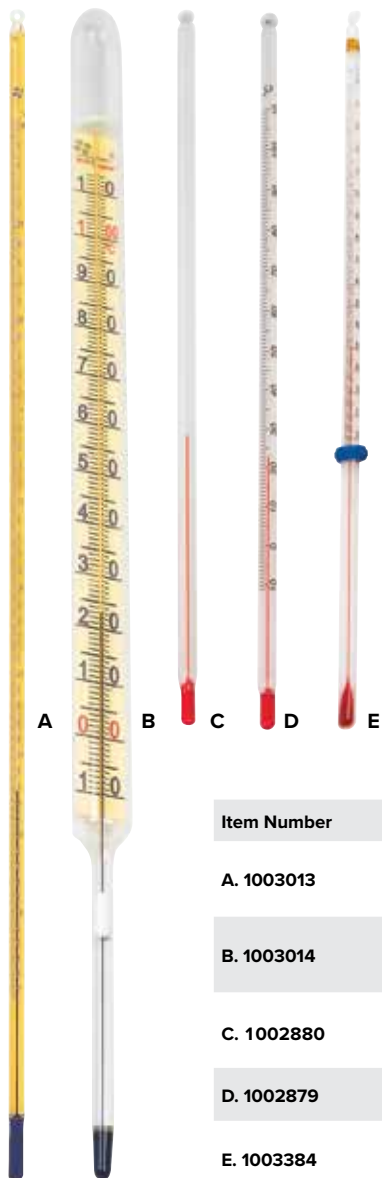

Insertion Thermometer
Used for measuring the temperature in air, liquids and soft materials. Temperature sensor made of stainless steel with protective case, switchable between °C and °F, On/Off switch and automatic switch-off.
Measuring range: -50°C to 150°C / -58°F to 302°F
Division: 0.1°C/F
Accuracy: ± 1°C / ± 2° F
Temperature sensor: 130 x 4 mm Ø
Mass: 29 g
1003334 \$25.99

Surface Thermometer
Used for measuring the temperature of surfaces. Temperature sensor made of stainless steel and with measurement contact area in the form of a disc, switchable between °C and °F, On/Off switch and automatic switch-off.
Measuring range: -50°C to 300°C / -58°F to 572°F
Division: 0.1°C/F
Accuracy: ± 1°C / ± 1.8°F
Temperature sensor: 130 x 4 mm Ø
Measurement disc: 18 mm Ø
Mass: 30 g
3004191 \$25.99

| Item Number | Features | Scale | Measure Range | Dimensions | Price |
|-------------|---|--------|------------------|---------------|----------------|
| A. 1003013 | Stable tube-type thermometer with biodegradable special blue filling, scale on yellow background, with eyelet. | 0.2° C | -1° C to 101° C | 460 x 7mm Ø | \$35.00 |
| B. 1003014 | Extra-large tube-type thermometer with biodegradable special blue filling, easy-to-read scale on yellow background. | 1° C | -10° C to 110° C | 650 x 30mm Ø | \$55.00 |
| C. 1002880 | For demonstrating function and mode of operation of thermometers, like U14295 but without scale. | -- | -- | 260 x 6mm Ø | \$8.00 |
| D. 1002879 | | | -10° C to 110° C | | \$7.00 |
| E. 1003384 | Tube-type with anti-roll design, white coated capillary, red alcohol filling, packed in a plastic tube. | 1° C | -20° to 110° C | 295 x 6.3mm Ø | \$5.00 |

K-Type NiCr-Ni Immersion Sensor, -65° C to 550° C
Temperature measurement sensor with stainless steel (V4A)-tube, spring-mounted (rigid) and silicone cable.
Measuring range: -65°C to 550°C
Response time: approx. 3 sec
Tube: 130 mm x 1.5 mm Ø
1002804 \$87.00

K-Type NiCr-Ni Immersion Sensor, -200° C to 1150° C
Sheath thermocouple with stainless steel (Inconel) tube, flexible and silicone cable.
Measuring range: -200°C to 1150°C
Response time: approx. 3 sec
Tube: 150 mm x 1.5 mm Ø
1002805 \$113.00



Micro IR Thermometer

Economical contactless temperature measurement for basic needs.

- Wide Temperature range from -34 to 446°F
- Micro size designed for convenience
- Max and Min Hold
- Complete with CR2032 3V Battery

3004165 \$39.99



Pocket IR Thermometer

Handy troubleshooting thermometer with laser pointer that measures to 518°F (270°C).

Features:

- Economical small pocket size design for convenience
- Built-in laser pointer identifies target area
- Data Hold and Max Hold
- Fixed emissivity covers 90% of surface applications
- Auto power off
- Complete with two AAA batteries

3004209 \$59.99



Mini IR Thermometer

- Built-in laser pointer identifies target area
- Backlighting illuminates display for taking measurements at night or in areas with low background light levels
- Automatic Data Hold when trigger released
- Fixed 0.95 emissivity covers 90% of surface applications
- Auto power off after 6 seconds

Measuring range: -4°F to +500°F; -20°C to +260°C / 1°C/F
 Accuracy: ± 3% of reading ± 3°C / 6°F whichever is greater
 Emissivity: 0.95 fixed value
 Laser power: Less than 1mW
 LCD display: Dual-function, 2,000 count LCD, backlighting and function indicators
 Power supply: 9 V battery
 Dimensions: 170 x 44 x 40 mm
 Mass: 140 g
3004207 \$79.99



High Temperature IR Thermometer

- Widest temperature range from -58° to 1400°F (-50 to 760°C)
- Built-in laser pointer identifies target area
- High 16 to 1 distance to target ratio measures smaller surface areas at greater distances
- Backlighting illuminates display for taking measurements at night or in areas with low background light levels
- Automatic Data Hold
- Automatic shut off after 6 seconds

Measuring range: -58°F to +1400°F; -50°F to +760°C
 Divisions: 0.1°C/F
 Accuracy: (2%+2°) at <932°F (500°C) ± (2.5%+5°) at >932°F (500°C)
 Emissivity: 0.95 fixed value
 Laser power: Less than 1mW
 LCD Display: 3 digit backlit LCD with function indicators
 Power supply: 9 V battery
 Dimensions: 100 x 56 x 230 mm
 Mass: 290 g
3004208 \$179.99



Datalogging Differential Thermometer - IR Thermometer

Take differential temperature readings with dual Type K thermocouple probes plus non-contact surface temperature measurement using IR Thermometer Probe (included).

Features:

- Datalogs up to 18,000 readings
- Heavy Duty rugged housing
- MAX/MIN/AVG and Data Hold
- Use IR Thermometer probe to measure non-contact surface Temperature up to 1,022°F (550°C); 8:1 distance to spot ratio and Laser pointer
- Includes two Type K bead wire temperature probes (-4 to 482°F/-20 to 250°C), IR Thermometer probe, Windows® compatible software with USB cable, hard carrying case, and 9V battery

3004200 \$249.99

➤ Digital measuring device for contact-free temperature measurement!



Infrared Temperature and Humidity Gauge

Digital measuring device for contact-free temperature measurement from large distances of hot or moving objects, or inaccessible points of measurement, and for simultaneous humidity display. The thermometer contains a backlit display and a laser diode is integrated to aid in detection.

Measuring range: (0.1° accuracy),
Temperature: -50° C – +500° C; -

58° F – +932° F

Dimensions: 90 x 170 x 45 mm"

Mass: 360 g

1002795 \$176.00



Digital Hygro-thermometer

Used for displaying exterior and interior temperature and humidity. With min/max function and acoustic signal if exterior temperature drops to or below zero, switchable between °C and °F, on/off button, eyelet for hanging up and fold-out stand.

Measuring range: Temperature (interior): 0° C - 50°C/ 32°F - 122°F

Temperature (exterior): -50° C - 70°C/ -58°F - 158°F

Humidity: 20% - 99%

Divisions: 0.1°C/F, 1%

Accuracy (temp.): ± 1°C / ± 2°F

Accuracy (humidity): ± 3%

Exterior temperature sensor:

Cable length 3 m

1003011 \$75.00



Infrared Thermometer

Surface thermometer for contactless temperature measurement from a safe distance, e.g. in inaccessible places, hot or moving objects. With laser diode for laser sighting, illuminated LCD display, range overflow display, measured value storage function, selection between Celsius and Fahrenheit, automatic switch off. Includes bag and battery.

1002791 \$150.00



Digital Pocket Thermometer

Stainless steel temperature sensor with a protective case is watertight, switchable between °C and °F, Min/Max/Hold functions with automatic switch-off.

Dimensions: 150 x 20 x 18 mm, 20 g.

Measuring range: -40°C to 200°C / -40°F to 392°F

Division: 0.1°C/F

Accuracy: ± 1°C / ± 2°F

1003335 \$20.99



Suspension Hook Clamp

Powder coated, 93 g

1002828 \$13.00



Bosshead Clamp

Powder coated, 110 g

1002827 \$12.00



Cross Bosshead Clamp

Powder coated, 160 g

1002831 \$23.00



Clamp with Jaw Clamp

Clamping width:

20 up to 40 mm

1002829 \$22.00



Universal Clamp

Clamping width:

0 up to 80 mm

1002833 \$24.00



Universal Bosshead Clamp

Angular screws, 135 g

1002830 \$30.00



Table Clamp

Powder coated, 350 g

1002832 \$35.00



Base, 1 kg

Heavy base for holding rods

1002834 \$32.00



Tripod Stand with Base

Base 6" legs,

rod 1/2 x 36 in

1002836 \$66.00



Barrel Feet:

1 kg

1001045 \$55.00

0.6 kg

1001046 \$37.00



Maximum-minimum Thermometer

Reading of maximum, minimum and instantaneous temperature. In plastic housing with reset button and hanging strap. Mercury filling.

Measuring range: -38°C to 50°C
 Divisions: 1°C
 Dimensions: 230 x 85 mm

1002878 \$21.00



Laboratory Jacks

Height-adjustable stand for elevated positioning of demonstration devices and continuous height adjustment of individual devices forming part of an experiment set-up.

| Item Number | Usable Area (cm) | Max Load | Height (mm) | Weight | Price |
|----------------|------------------|----------|-------------|--------|-----------------|
| 1002941 | 20 x 20 | 40 kg | 70 - 260 | 2.3 kg | \$106.00 |
| 1002942 | 16 x 13 | 50 kg | 65 - 250 | 1.2 kg | \$122.00 |
| 1002943 | 32 x 22 | 30 kg | 65 - 250 mm | 2.6 kg | \$223.00 |

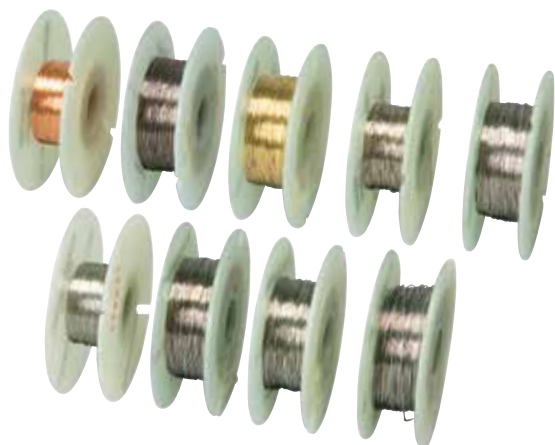

Resistance Wires

Metal wires on bobbins, e.g. for experiments to investigate how resistance depends on the material, cross-sectional area and length of the wire.

| Item Number | Material | Length | Diameter | Price |
|----------------|---------------|--------|----------|----------------|
| 1000949 | Copper | 100 m | 0.3 mm | \$14.00 |
| 1000950 | Iron | 100 m | 0.3 mm | \$16.00 |
| 1000959 | Brass | 50 m | 0.3 mm | \$14.00 |
| 1000951 | Nickel | 50 m | 0.3 mm | \$21.00 |
| 1000953 | Chrome-Nickel | 100 m | 0.3 mm | \$18.00 |
| 1000954 | Chrome-Nickel | 50 m | 0.5 mm | \$18.00 |
| 1000955 | Constantan | 100 m | 0.2 mm | \$16.00 |
| 1000956 | Constantan | 100 m | 0.3 mm | \$21.00 |
| 1000957 | Constantan | 50 m | 0.4 mm | \$21.00 |
| 1000958 | Constantan | 50 m | 0.5 mm | \$25.00 |

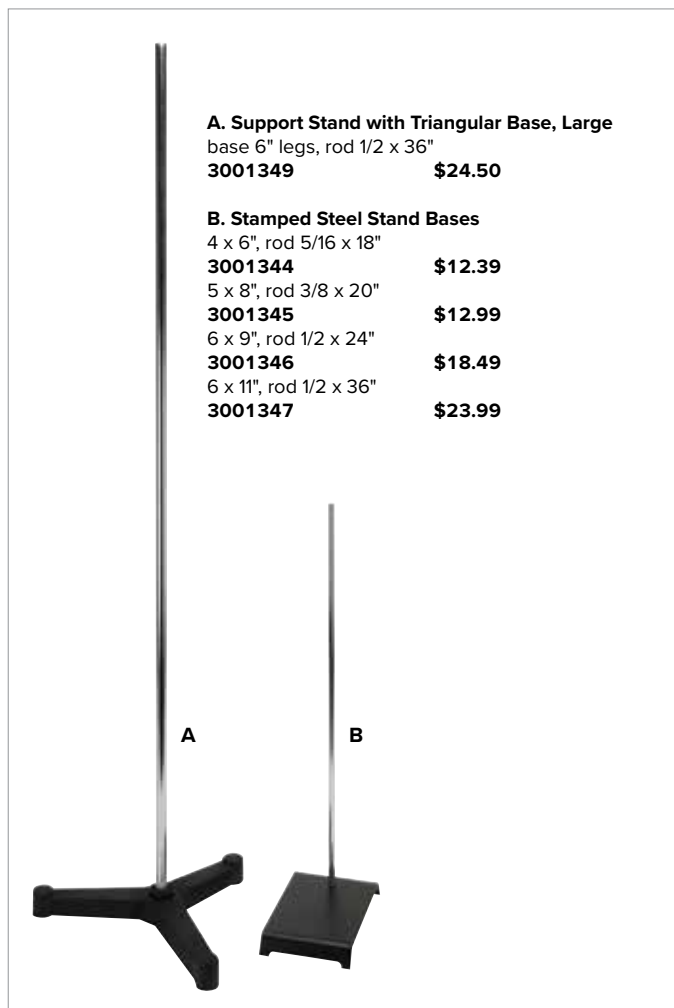

A. Support Stand with Triangular Base, Large
 base 6" legs, rod 1/2 x 36"

3001349 \$24.50

B. Stamped Steel Stand Bases

- 4 x 6", rod 5/16 x 18" **3001344 \$12.39**
- 5 x 8", rod 3/8 x 20" **3001345 \$12.99**
- 6 x 9", rod 1/2 x 24" **3001346 \$18.49**
- 6 x 11", rod 1/2 x 36" **3001347 \$23.99**



Stainless Steel Rod

Constructed from straight, non-corrosive stainless steel.

| Item Number | Length | Diameter | Price |
|----------------|--------|----------|----------------|
| 1002932 | 10 cm | 12 mm | \$9.00 |
| 1002933 | 25 cm | 12 mm | \$7.00 |
| 1002934 | 47 cm | 12 mm | \$15.00 |
| 1002935 | 75 cm | 12 mm | \$21.00 |
| 1002936 | 100 cm | 12 mm | \$13.00 |
| 1002937 | 150 cm | 12 mm | \$19.00 |

| | | | |
|----------------------------------|----------------------------|---|-------------------|
| A | | | |
| Acoustics..... | 150-157 | Hand Skeleton..... | 12-13 |
| Aerodynamics..... | 149 | Head Models..... | 39 |
| AIDS/HIV..... | 61-62 | Health Education..... | 60-77 |
| Alcohol Education..... | 72 | Heart Models..... | 52-53 |
| Anatomical Charts..... | 90-91 & <i>more online</i> | Heat..... | 178-185 |
| Anatomical Models..... | 2-59 | Hemorrhoid Models..... | 56 |
| Animal Cell Model..... | 96 | Hernia Models..... | 56 |
| Animal Skeletons..... | 100-109 | Hip Joint Models..... | 18 |
| Anthropology Skulls..... | 98-99 | Humerus..... | 14 |
| Arm Skeleton..... | 12-13 | | |
| Atomic Physics..... | 204-212 | I | |
| | | Induction..... | 170-175 |
| B | | Instrumentation..... | 213-227 |
| Birth Process Models..... | 65-66 | | |
| Body Fat Monitors..... | 74 | J | |
| Bone Structure Models..... | 15 | Jaw Models..... | 46-47 |
| Botany..... | 93-95 | | |
| Brain Models..... | 39-42 | K | |
| BSE (Breast Self Exam)..... | 63-64 | Kidney Models..... | 55-56 |
| | | Knee Joint Models..... | 18 |
| C | | | |
| Cables..... | 220 | L | |
| Career Tech-Medical..... | 78-89 | Lab Equipment..... | 212-225 |
| Cell Models..... | 96-97 | Leg Skeletons..... | 13 |
| Cervical Spinal Column..... | 20-25 | Life Support Training..... | 79-82 |
| Chemistry..... | 120-125 | Liver Models..... | 55 |
| Chemistry Sets..... | 122-124 | Lumbar Spinal Column..... | 20, 25 |
| Childbirth Demonstration..... | 67 | Lung Models..... | 48-49 |
| Cholesterol..... | 75 | | |
| Circulatory System..... | 49 | M | |
| Clavicle..... | 13-14, 18 | Magnetic Fields..... | 167-169 |
| Clean Energy..... | 125 | Mammal Feet..... | 105 |
| Comparative Anatomy..... | 100-109 | Mammograms Charts..... | 64 |
| Condom Training..... | 61-62 | Measuring Devices..... | 213-227 |
| CPR..... | 79-82 | Mechanics..... | 126-141 |
| | | Meiosis & Mitosis..... | 101 |
| D | | Microscopes..... | 109-110 |
| Dental Models..... | 50-51 | Minerals..... | 91 |
| Diabetes Education..... | 76-77 | Molecular Models..... | 103-108 |
| Digestive System..... | 54-57 | Multimeters..... | 218 |
| Disarticulated Skeletons..... | 11 | Muscle & Fat Replicas..... | 69 |
| DNA Models..... | 125 | Muscle Figures & Models..... | 26-31 |
| | | | |
| E | | N | |
| Ear Models..... | 46-47 | Nervous System..... | 35-39 |
| Earth Sciences..... | 116-119 | Nuclear Physics..... | 202-212 |
| Elbow Joint Models..... | 18-19 | Nutrition Education..... | 69 |
| Electricity & Magnetism..... | 155-172 | | |
| Electron Tubes..... | 132-134 | O | |
| Embryo Models..... | 65-66 | Optics..... | 183-201 |
| Engines..... | 183-185 | Oscillation..... | 133-138 |
| Epidural..... | 83 | Oscilloscopes..... | 220 |
| Experiment Kits..... | 127-131 | Osteoporosis Models..... | 15-16 |
| Eye Models..... | 44-45 | | |
| | | P | |
| F | | Parenting Education..... | 62 |
| Female Contraceptive Models..... | 57 | Patella..... | 9 |
| Femur..... | 22-23, 58 | Pediatric Spine Model..... | 17 |
| Fetal Skulls..... | 29 | Pelvic Models..... | 57-59 |
| Fibula..... | 14 | Periodic Table of the Elements Chart..... | 119 |
| Field Testing..... | 93 | Physics..... | 126-227 |
| Flower Models..... | 93-95 | Placenta, Embedded..... | 65 |
| Foot Models..... | 12-13, 16-17, 77 | Plant Cell Models..... | 98 |
| Fossils..... | 118-119 | Plant Models..... | 95-97 |
| Franck-Hertz..... | 209 | Plate Tectonics..... | 115 |
| Fuel Cells..... | 177 | Power Supplies..... | 213-214 |
| | | Pregnancy..... | 65-66 |
| G | | | |
| Gall Bladder, Liver with..... | 55 | R | |
| Gallstone Model..... | 55 | Radiation..... | 128, 208, 211-212 |
| Glucose Molecule..... | 124 | Radius..... | 142 |
| Green Chemistry..... | 122-124 | Ready-Or-Not Tots..... | 67 |
| | | Reproductive Education..... | 61-62 |
| H | | Rocks..... | 91 |
| | | Rotation..... | 134-136 |
| | | | |
| | | S | |
| | | Sacrum and Coccyx..... | 8-9 |
| | | Scapula..... | 8-9 |
| | | Shoulder Joint Models..... | 11 |
| | | Skeleton Models, Human..... | 2-10 |
| | | Skin Models..... | 34 |
| | | Skull Models, Human..... | 20-23 |
| | | Smoking Education..... | 63-67 |
| | | Spine Models..... | 18-19 |
| | | Statics & Dynamics..... | 128-131 |
| | | STD Education..... | 56-57 |
| | | Stirling Engines..... | 179-182 |
| | | Stomach Models..... | 50 |
| | | Substance Abuse Education..... | 68-71 |
| | | | |
| | | T | |
| | | Teltron..... | 121-124 |
| | | Thermodynamics..... | 173-182 |
| | | Thoracic Spinal Column..... | 15 |
| | | Tibia..... | 8-9 |
| | | Tobacco Education..... | 63-67 |
| | | Tooth Models..... | 44-45 |
| | | Torso Models, Human..... | 30-33 |
| | | Transformers..... | 168-170 |
| | | TSE (Testicle Self Exams)..... | 56 |
| | | | |
| | | U | |
| | | Ulcers, Stomach with..... | 50 |
| | | Ulna..... | 8-9 |
| | | Ultrasound & Ultrasound..... | 149-159 |
| | | Urinary System..... | 51-54 |
| | | | |
| | | V | |
| | | Vacuums..... | 139-140 |
| | | Vertebral Columns..... | 18-19 |
| | | Volcanic Activity..... | 90 |
| | | | |
| | | W | |
| | | Waves..... | 142-154 |
| | | | |
| | | Z | |
| | | Zoology..... | 94-96 |

Still can't find it? Let an Expert Help.

Visit us at 3bscientific.com or
Call 1.866.448.5846!

3B SCIENTIFIC PRODUCT RANGE



SCIENCE EDUCATION

Anatomical models are an essential teaching tool in science education of all levels. They make a visual and hands-on demonstration possible that effectively supports the comprehension of the human anatomy. Most of our key products have been cast from actual specimens. This is why 3B Scientific® models come as close to reality as possible, they are made of highest quality material and lead the industry in durability.

CAREER TECH

For basic health training, or advanced tech programs, simulators are used to teach students the skills they need to be prepared for real life cases. These simulators must be as close to reality as possible, be of great quality, hygienic and also economical in long-term use. You will find simulators for all your training needs that are manufactured to meet all your standards and skill levels at 3bscientific.com.

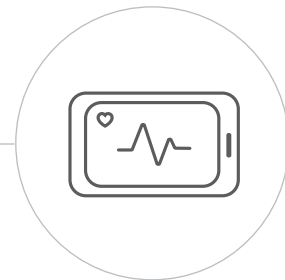

EARTH SCIENCE

Teach your students the importance of earth and bring them to a better understanding of our environment. We have developed a wide variety of interesting products, working with renowned experts for you to bring earth science to your classroom.

CHEMISTRY

Students will gain firsthand experience in the fundamentals of chemistry by constructing models of organic and inorganic structures representing numerous chemicals, molecules, crystals and other compounds. Build hundreds of different structures while gaining an understanding of elemental particles. Our chemistry kits will engage students in safe, convenient and fun lab investigations of basic chemical reactions. Get started assembling, testing, and learning chemistry fundamentals today.



BIOLOGY

Engaging Biology classes are the most effective way to create a long-lasting learning experience. 3B Scientific® models are the perfect tool for fascinating, hands-on education, being cast from actual specimens and made of highest quality material.

PHYSICS

Hands-on, inquiry-based education lies at the heart of teaching physics. At 3B Scientific®, you will find exciting, simple and thought provoking products to actively engage your students.

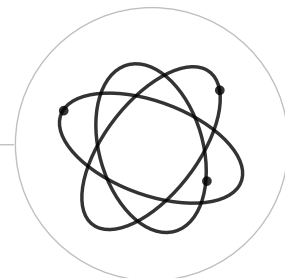

Your Priority Code:



We're open **Monday - Friday** 8:00am until 7:00pm EST
Fax orders toll free anytime at **1.866.992.1514**

Ordering Information

Toll Free Phone: **1.866.448.5846**

E-mail: **sales@a3bs.com**

Order online at **3bscientific.com**

FREE SHIPPING 

Enter **priority code** above during checkout for **Free Shipping***



Popular models created for students, universities and scientists all over the world!

The Animal Cell

This two-piece model shows the form and structure of a typical animal cell as viewed from an electron microscope. For the purpose of better illustration, all important organelles are raised and displayed in color. On removable base. 21 x 11 x 31 cm; 0.8 kg
1000523 \$342.00

For more information about this model please turn to page 96.