

Demonstration oscilloscope 1000902

Instruction sheet

05/16 CW/ALF/UD

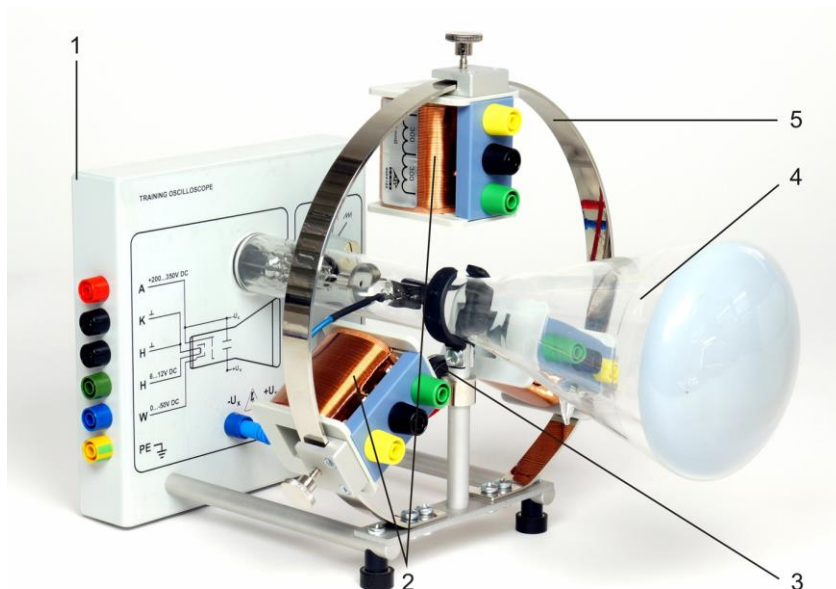

- 1 Electronic control unit
- 2 Deflecting coils
- 3 Circular magnet
- 4 Cathode ray tube
- 5 Metal ring

1. Safety instructions

The demonstration oscilloscope is operated with voltages, some of which are above 60 V.

- Always turn off power supply before making connections.
- Use safety leads.

Since the glass tube is evacuated, there is an implosion hazard.

- Do not subject the tube to sharp blows or mechanical stress.

In schools and training institutions, operation of the device is to be responsibly supervised by trained personnel.

2. Description

The demonstration oscilloscope can be used to show the deflection of an electron beam by electric and magnetic fields, just as employed in TVs or conventional oscilloscopes. Essentially, it consists of a cathode ray tube that is supplied with

voltage via 4-mm plugs and is surrounded by a ring, to which deflecting coils can be attached.

A cathode ray tube is an evacuated glass tube, the neck of which contains a heated cathode and an anode in the shape of a disc with a hole in the middle, separated by a distance of approximately half a centimetre. Electrons emitted from the heated cathode are accelerated towards the anode. Some of them pass through the hole to form a beam that strikes the fluorescent screen (with zinc silicate coating) and thus becomes visible as a green fluorescent dot. The beam is focussed partly by a Wehnelt cylinder surrounding the cathode, the potential of which is negative with respect to the cathode potential, and partly by gas constriction as a result of the tube being filled with neon at a pressure of approx. 1 Pa that also renders the beam visible inside the tube.

There are also two opposing deflection plates in the tube, oriented parallel to the beam, which can be connected to the integrated saw-tooth generator, or to an external voltage supply. The generator supplies saw-tooth voltage waveforms with a frequency range of 3.5 to 650 Hz and an amplitude of 100 V relative to the anode potential.

3. Technical data

Anode voltage:	200...350 V DC
Anode current:	1 mA max.
Heater voltage:	6...12 V DC
Wehnelt voltage:	-50...0 V DC
Size of deflection plates:	12 x 20 mm ²
Distance of deflection plates:	14 mm
Deflecting coils:	300 + 300 turns R _i = 4.2 Ω L = 6 mH
Saw-tooth voltages:	V _{pp} = 100 V f = 3.5..650 Hz

4. Operation

4.0 Electronic control unit

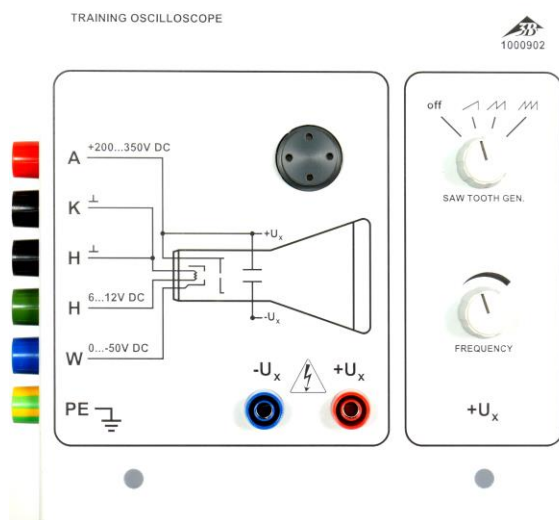

Fig. 1: Electronic control unit

Inputs:

A	Anode
K	Cathode
H	Heating
W	Wehnelt cylinder
⊥	Ground
PE	Protective earth

Outputs:

-U _x	Negative voltage for deflection plate, left
+U _x	Positive voltage for deflection plate, right

Saw-tooth generator:

	Single frequency
	Double frequency
	Triple frequency
Frequency:	Saw-tooth frequency

4.1 To start operation

In order to supply current to the demonstration oscilloscope, power supplies are required that can output the following voltages:

- 200-350 V DC, regulated,
- 0-50 V DC, regulated,
- 6-12 V DC.

Power supplies 1001011 / 1001012 and 1003307 / 1003308, which can supply all of these voltages, are particularly well suited to this end.

Note:

As a rule, the training oscilloscope operates at anode voltages up to about 300 V depending on what tube is connected. The anode voltage must not, however, exceed 350 V.

- Turn off the power supply.
- Connect the inputs of the demonstration oscilloscope to the outputs of the power supply, that supply the specified voltages.
- Adjust the voltage so as to not to exceed the limits.
- Turn on the power supply.

After 10-30 sec, a green spot appears on the fluorescent screen, which denotes where the electron beam is hitting the screen. In order to keep the tube as simple and clear as possible for educational purposes, it was decided to do without additional apparatus for secondary acceleration and focusing of the beam. For this reason, it is not usually possible to focus the beam to the sharpness seen in conventional oscilloscopes.

- Vary the Wehnelt voltage until the spot reaches its minimum dimensions.

The electron beam is visible as a reddish thread inside the tube, but only in a darkened room because of its low intensity.

4.2 Deflecting apparatus

4.2.1 Electrical deflection

Using the deflecting plates located inside the tube, the electron beam can be deflected horizontally by applying a voltage of up to 100 V. For most applications, a saw-tooth generator is used to supply this voltage. In this case, the beam goes from left to right and then quickly flicks back again. This is repeated at a fixed frequency that can be adjusted. By this means it is possible to display vertical deflections that are also periodic, such as an alternating magnetic field.

4.2.2 Magnetic deflection

Attach the coils to the magnetic ring surrounding the neck of the tube. Between each neighbouring socket, there are 300 turns so that if a connection is made to the two outer sockets, the current flows through all 600 turns. The electron beam is deflected to the right, perpendicular to the magnetic field and the direction of the beam. If the coils are mounted facing inward, even small currents of a few milliamps will be noticeable.

4.2.3 Beam adjustment

A magnet is attached to the tube support in the middle that can be adjusted by a screw so that

the beam can be aligned to strike a specific point on the screen when the deflecting apparatus is turned off.

4.3 Saw-tooth generator

The outputs of the saw-tooth generator are located below the mounts at the rear of the tube and are labelled $-U_x$ and $+U_x$, respectively.

A saw-tooth voltage (also frequently called a ramp) is a voltage that changes periodically over time, increasing or decreasing linearly from an initial value then returning instantaneously to the start.

Caution: the saw-tooth voltage is relative to the anode potential of +250 V.

The upper knob is used to turn on the generator and make a coarse adjustment of the frequency. Fine adjustment is completed with the lower knob.

5. Sample experiments

5.1 Electrical deflection of the electron beam

- Set up the experiment as in fig. 2.
- Turn off the voltage supply to the demonstration oscilloscope
- Connect deflecting plates to the output of the saw-tooth generator.
- Adjust the electron beam so that it strikes the fluorescent screen on the left-hand side (about 1 cm from the edge).
- Set the coarse adjustment of the saw-tooth frequency to its minimum level (second position from the left).
- Turn on the voltage supply.

After 10-30 sec, the fluorescent dot appears on the screen. It should migrate periodically from left to right.

- If necessary, decrease the frequency using the fine adjustment knob so that the migration of the point can be clearly tracked.

5.2 Magnetic deflection of the electron beam

- Set up the experiment as in fig. 3.
- Attach a coil to the metal ring.
- Connect the inputs of the coil to the DC power supply.
- Adjust the electron beam so that it strikes the centre of the fluorescent screen.
- Turn on the DC power supply and vary the current to the coil.

The beam is deflected perpendicularly to the direction of both the beam and the magnetic field.

- Change the polarity and alignment of the coil and the number of turns the current flows through and observe the effects.

5.3 Trace of an AC voltage over time

Additional equipment required:

1 Function generator (50 Ω , with amplifier if possible) or AC power supply.

Optional: 1 Multimeter with frequency counter (maximum voltage, at least 150 V).

- Set up the experiment as in fig. 4.
- Follow the instructions for experiment 5.1, but do not decrease the frequency, and set the coarse adjustment to the medium level. If a multimeter with frequency counter is available, connect it to the outputs of the saw-tooth generator in parallel with the deflection plates before turning on the voltage supply. (Caution: it is dangerous to touch the saw-tooth voltage outputs)
- Attach a coil to the metal ring.
- Connect the inputs of the coil to the function generator (amplified if available).
- Select a frequency between 30 and 100 Hz on the function generator.

During movement from the left to the right side, the beam is vertically deflected.

- If necessary, increase output voltage to obtain a bigger deflection.

Due to the rapid repetition, it is hard to see a waveform for the AC voltage, since recording usually does not start the same point during the period (the same phase) so that multiple phase-shifted images are therefore superimposed. This problem does not occur if the saw-tooth frequency is identical to the input signal frequency of the function generator.

- With the fine adjustment, search for a frequency at which a standing image appears, which shows a clear period of oscillation.

At which other saw-tooth frequencies does a standing image also appear?

5.4 Lissajous figures

Additional equipment required:

1 Function generator (50 Ω , with amplifier if possible), and 1 AC power supply or 2 function generators.

- Set up the experiment as in fig. 5.
- Attach a coil to the metal ring pointing inward, with the axis aligned horizontally.
- Connect the inputs (green, yellow) to the AC power supply or to the second function generator (set to a 50 Hz sinusoidal voltage). Select the amplitude so that the line appearing on the screen is approximately half the length of the screen diameter.
- With the circular magnet, adjust the line horizontally to centre it.
- Mount another coil to the metal ring pointing inward, with the axis aligned vertically.
- Connect the inputs (green, yellow) to the first function generator (set to a 50 Hz sinusoidal voltage).

An ellipse appears that changes shape at faster or slower speed, depending on how well the frequencies of the input signals match. This takes the shape of a sloped straight line twice per cycle.

- Adjust the amplitude of the first function generator so that the slope of the straight line is 45° and that a circle emerges during transition.

The simplest Lissajous figures can be observed already. The shapes depend on the frequency ratios and on the phase shift. Due to a small deviation from the exact target frequency on either of the two function generators (usually, the inaccuracy of the devices is already sufficient), the phase shift cycles automatically, and all figures for a specific frequency ratio can be observed in succession.

- Set the frequency of the first function generator to a multiple of the horizontal frequency (50 Hz).

Observe Lissajous figures for the frequency ratios 2:1, 3:1 and 4:1.

- Further Lissajous figures are created by fractional multiples of the horizontal frequency (e.g., 3:2 (75 Hz), 4:3 (66.7 Hz)).

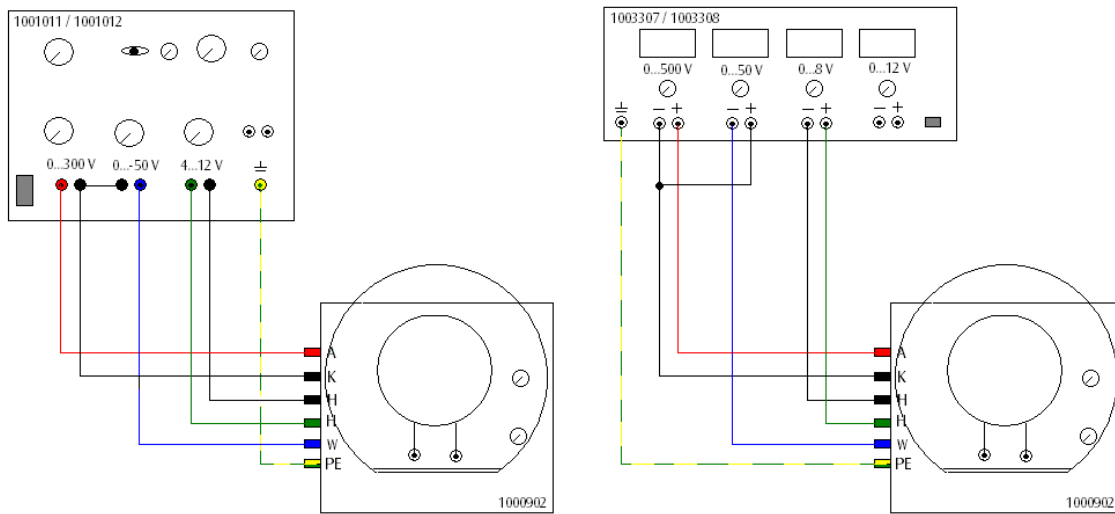

Fig.2 Electrical deflection of the electron beam (left: with power supply 1001011 / 1001012, right: with power supply 1003307 / 1003308).

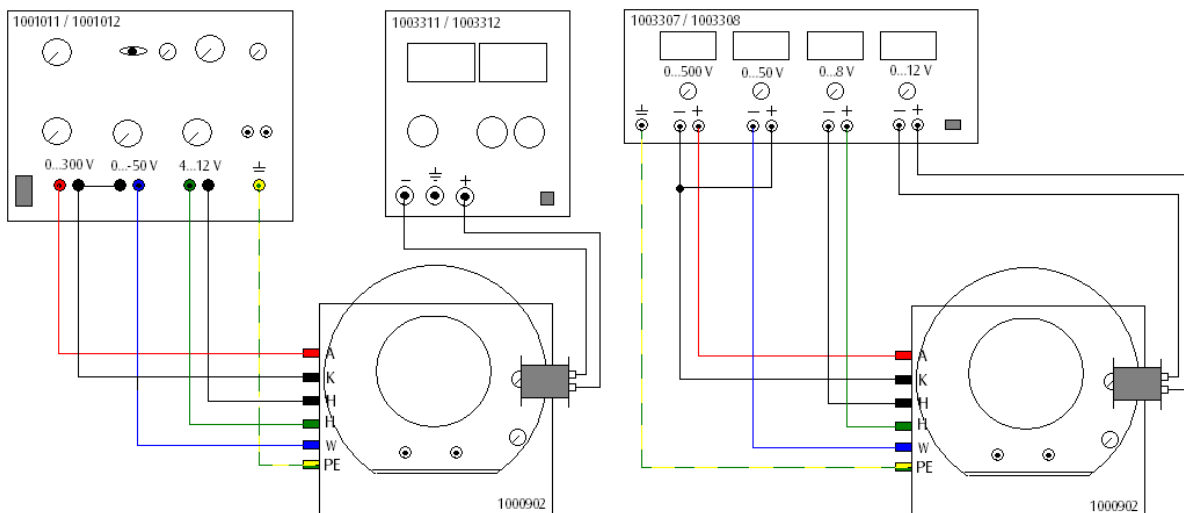

Fig.3 Magnetic deflection of the electron beam (left: with power supply 1001011 / 1001012 and power supply 1003311 / 1003312, right: with power supply 1003307 / 1003308).

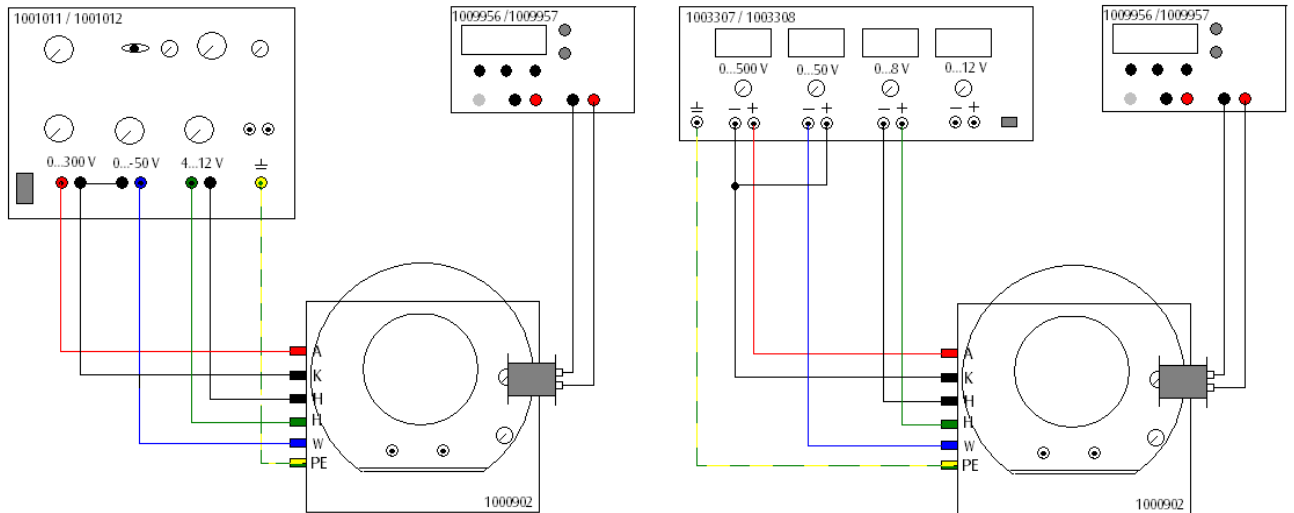

Fig.4 Trace of an AC voltage over time (left: with power supply 1001011 / 1001012 and function generator 1009956 / 1009957, right: with power supply 1003307 / 1003308 and function generator 1009956 / 1009957).

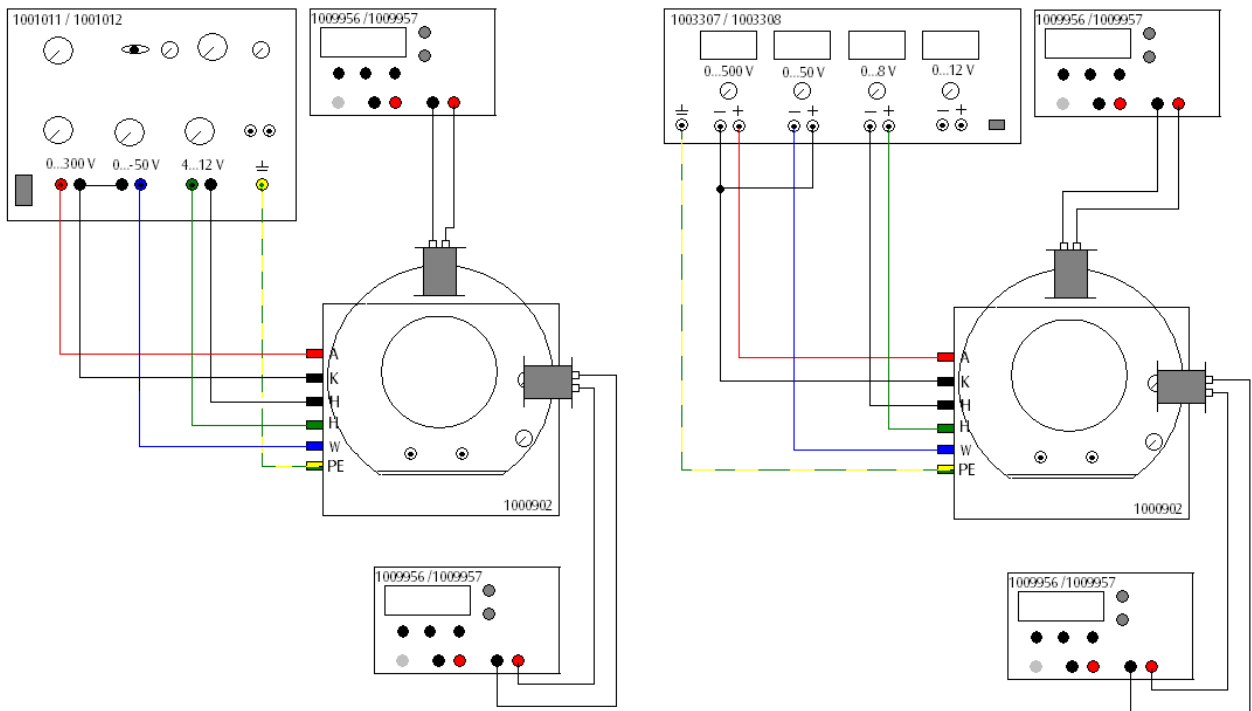

Fig.5 Generating Lissajous figures (left: with power supply 1001011 / 1001012 and 2x function generator 1009956 / 1009957, right: with power supply 1003307 / 1003308 and 2x function generator 1009956 / 1009957).

