

## Pair of Helmholtz Coils 1000906

### Instruction sheet

09/15 SP



- 1 Connection sockets
- 2 Knurled screw for mounting the rotating frame with flat coil
- 3 Pair of coils
- 4 Spring clip for Hall sensor

### 1. Description

The Pair of Helmholtz coils is used for generating a homogeneous magnetic field. In conjunction with the rotating frame with flat coil (1013131), the Helmholtz coils are also used in experiments for investigating induction and magnetic levitation and for the determination of the specific charge of the electron  $e/m$  in conjunction with the electron-beam tube (1000904). The coils can be switched in parallel or in series. A spring clip on the top crossbar is used to mount the Hall sensor during measurements of the magnetic field.

### 2. Technical data

Number of turns per coil:	124
Outer coil diameter:	311 mm
Inner coil diameter:	287 mm
Mean coil radius:	150 mm
Coil spacing:	150 mm
Enamelled copper wire thickness:	1.5 mm
DC resistance:	1.2 Ohm each
Maximum coil current:	5 A
Maximum coil voltage:	6 V
Maximum flux density at 5 A:	3.7 mT
Weight:	4.1 kg approx.

### 3. Theoretical bases

The special arrangement of the coils is attributed to the physicist Hermann von Helmholtz. Two narrow coils with a large radius  $R$  are set up parallel to one another and on the same axis so that they are also separated by a distance  $R$ . The magnetic field of each individual coil is non-uniform. Upon superimposition of the two fields, a region with a magnetic field that is largely uniform is created between the two coils.

Given the Helmholtz arrangement of the pair of coils and coil current  $I$ , the following holds true for the magnetic flux density  $B$  of the magnetic field:

$$B = \left(\frac{4}{5}\right)^{\frac{3}{2}} \cdot \mu_0 \cdot I \cdot \frac{n}{R}$$

where  $n$  = number of turns in each coil,  $R$  = mean coil radius and  $\mu_0$  = magnetic field constant.

For the Helmholtz pair of coils, we get:

$$B = 7.433 \cdot 10^{-4} \cdot I \text{ in Tesla (} I \text{ in A).}$$

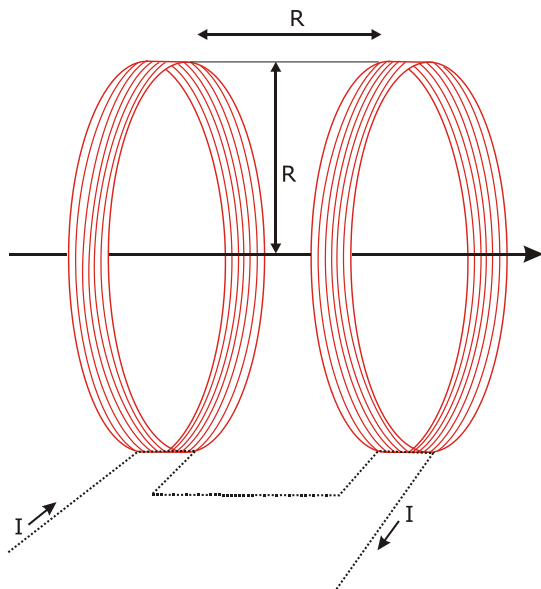

Fig. 1 Coils in Helmholtz arrangement

### 4. Sample experiments

In order to perform the experiments, the following equipment is also required:

1 AC/DC power supply 0-20 V, 5 A @230 V  
1003562

or

1 AC/DC power supply 0-20 V, 5 A @115 V  
1003561

2 Escola 100 multimeter 1013527

1 Rotating frame with flat coil 1013131

#### 4.1 Voltage induction in a magnetic field

- Position the Helmholtz coils on the table top and connect them in series to the DC power supply via an ammeter.
- Screw the supports of the rotating frame with the flat coil to the crossbar of the Helmholtz coils, so that the flat coil can rotate in the middle of the uniform field produced by the Helmholtz coils.
- Connect a voltmeter with a central zero point directly across the coil.
- Set the power supply current for the coils to about 1.5 A.
- Use the hand crank and observe the deflection of the voltmeter.
- Change the speed of rotation so that a larger deflection is obtained. The rotation speed needs to be low.

In order to achieve a constant speed of rotation, use of a slowly rotating motor (e.g. 12 V DC motor 1001041) is recommended for driving the rotating frame.

A precise voltage trace can also be observed and measured using an oscilloscope.

#### 4.2. Determination of the earth's magnetic field from the induction voltage

Using the same experiment set-up, it is also possible to measure the earth's magnetic field.

- Align the Helmholtz coils in such a way that the magnetic field of the coils is parallel to the Earth's field.
- Rotate the flat coil and observe the voltage.
- Increase current to the Helmholtz coils until the voltage induced at the outputs of the flat coil is zero (so that the earth's magnetic field and the field of the Helmholtz coils cancel out).
- When the induced current is 0, then the magnetic field in the coils is of the same magnitude as the Earth's magnetic field.

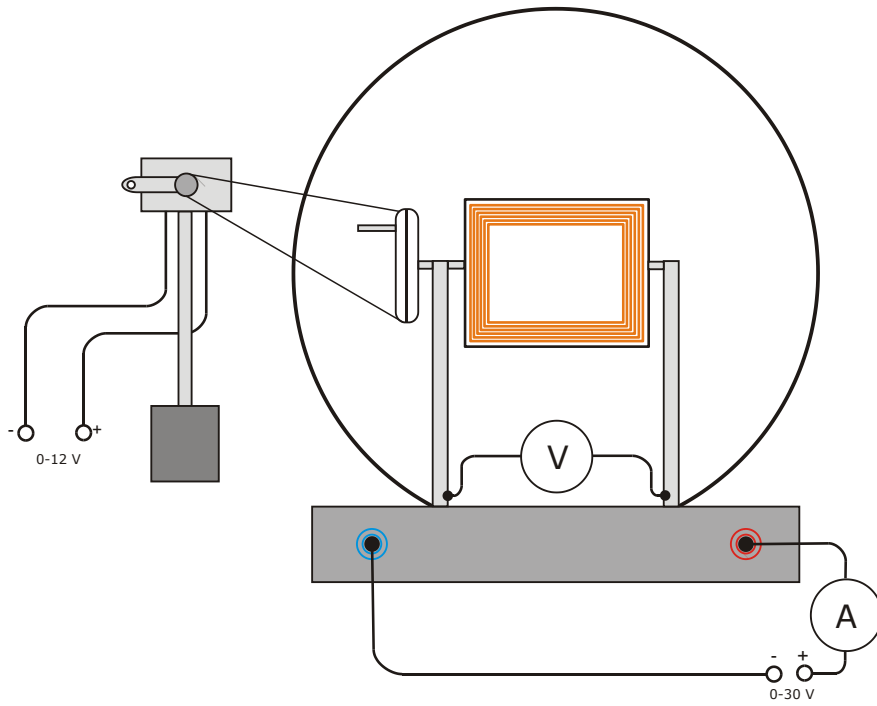

Fig. 2 Experiment set-up with flat coil and driving motor