

Vacuum Photocell 1000915

Gas Filled Photocell 1000916

Instruction Sheet

09/15 LT/ALF



- 1 Sockets for collector voltage
- 2 Clamping rod
- 3 Photocell tube
- 4 Output sockets

1. Safety instructions

When the instrument is used in accordance with the instructions and regulations, safe operation is ensured. However, safety is not guaranteed if the instrument has been treated inappropriately or carelessly.

If there is reason to believe that safe operation is no longer possible (e.g., if there is visible damage), the instrument must not be used, or if in use it must be taken out of service immediately.

When the photocell is used with the 500 V DC @230 V power supply (1003308) or the 500 V DC @115 V power supply (1003307), there may be voltages that are dangerous to touch in the area of the connections.

- Only use safety experiment leads for the connections.
- Only make connections when the voltage supply is switched off.
- Keep within the specified operating parameters.
- Do not expose the photocell to temperatures above 50°C.

- Do not expose the photocell to direct sunlight, and store it in darkness whenever possible.

2. Description

The vacuum photocell 1000915 and the gas-filled photocell 1000916 are used for demonstrating the photoelectric effect and the increase of the flow of electrons when the light intensity is increased.

The photocell mounting and the electrical circuit are protected for safe handling in a plastic housing with a clamping rod.

The photocell tubes have a base with 7 pins, and can only be fitted into the housing in the correct orientation. The light-sensitive side of the photocell is on the side of the anode filament which is approximately in the centre of the cathode shell.

Figure 1 shows the circuit of the photocell. The collector voltage U_b is applied to the pair of sockets (1), and produces an electric field between the cathode and the anode. The dependence of the photoelectric current on the

light intensity can be measured by connecting a microammeter to the other pair of sockets (2).

If the measurement is made by connecting a voltage amplifier, the voltage must be measured relative to the blue socket (1). As the measurement is made in parallel to the photocell in this case, the voltage at the amplifier input decreases as the light intensity is increased.

R2 and C1 provide smoothing of the collector voltage, and R2 also protects the photocell tube.

3. Operation

- Take the photocell tube out of the packaging and carefully plug it into the base.
- Protect the photocell from direct sunlight!

4. Sample experiments

4.1 Demonstration of the photoelectric effect

For carrying out the experiment, the following additional equipment is needed:

- 1 DC power supply, 500 V @230 V
1003308
- or
- 1 DC power supply, 500 V @115 V
1003307
- 1 Digital multimeter
1002785
- Light source
- Stand and clamps or optical bench

The experiment demonstrates the linear dependence of the photoelectric current on the light intensity.

- Set up the photocell using a stand and clamps or an optical bench (Fig. 2).
- With a constant collector voltage U_b and in a completely darkened room, place a light source (an optical lamp or a low-power light bulb) at a measured distance from the photocell.
- Read the value of the photoelectric current on the multimeter.
- Move the light source so that the distance to the photocell is half the previous value and again read the photoelectric current.

Halving the distance has the effect of quadrupling the photoelectric current.

5 Technical data

	1000915	1000916
Type:	Valvo 90CV	Valvo 90CG
Cathode:	Caesium on oxidised silver	Caesium on oxidised silver
Effective cathode area:	2.4 cm ²	2.4 cm ²
Wavelength for max. sensitivity:	850 nm	850 nm
Anode/cathode capacitance C_{AC} :	0.6 pF	0.6 pF
Collector voltage U_b :	50 V, max. 200 V	50 V, max. 90 V
Working resistance R_a :	1 M Ω	1 M Ω
Dark current I_0 :	0.05 μ A	0.1 μ A
Sensitivity:	20 μ A/lumen	125 μ A/lumen
Max. photoelectric current density I_k :	3 μ A/cm ²	0.7 μ A/cm ²
Max. ambient temperature:	50° C	50° C

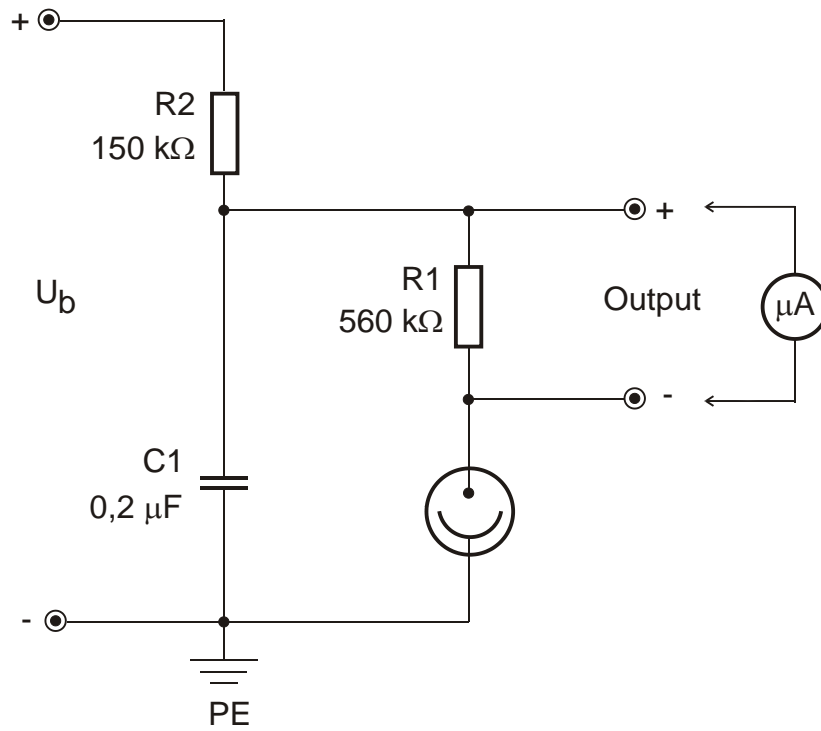

Fig.1 Circuit of the photocell

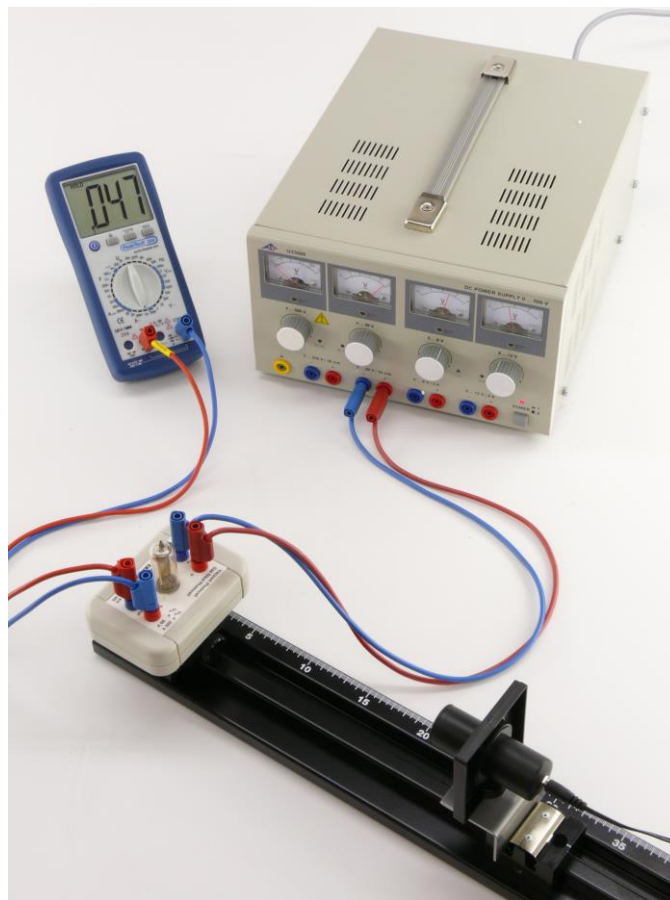

Fig. 2 Experiment set-up for demonstrating the photoelectric effect