

Precision Spherometer 1002947

Instruction sheet

06/18 ALF

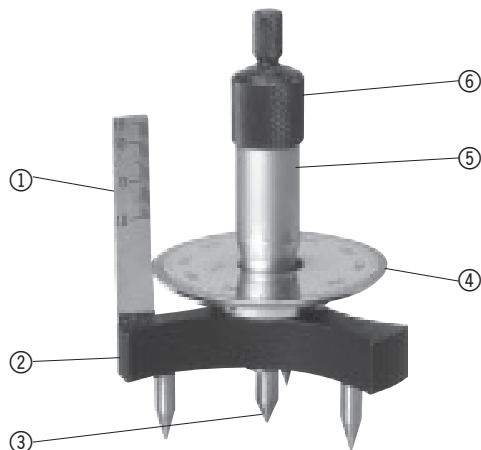

- ① Vertical scale
- ② Tripod
- ③ Measuring tip
- ④ Disc scale
- ⑤ Micrometer screw
- ⑥ Grub screw

The precision spherometer measures plate thickness, depressions and radii of curvature of spherical surfaces, e.g. lenses.

1. Description, technical data

The equipment consists of a tripod with three steel tips that form an equilateral triangle. A micrometer screw with a measuring pointer is set in the center. The grub screw attached to the micrometer screw serves to protect it and is not suitable for fine adjustment. The micrometer screw has a disc with a circular scale having divisions from 0 to 500. The tripod has a vertical scale marked from 10 to 15 mm. The height measured by a revolution of the spindle is 0.5 mm and can be read on the vertical scale, while fractions can be read on the circular scale where each marking corresponds to a 0.002 mm change in the height. This allows 0.001 mm accuracy. The separation of each of the three steel points on the tripod from the measuring point is 50 mm.

$$a = \frac{50\text{mm}}{\sqrt{3}} = 28.9\text{mm}$$

The zero point should be set before every measurement.

Measuring range: 0 to 25 mm
 -10 mm to 15 mm
 Screw pitch: 0,5 mm

Accuracy: 0,001 mm
 Separation of supports: 50 mm

2. Instructions for use

2.1 Setting the zero point

- Spherometer should be placed on a flat glass plate.
- Turn the Micrometer screw so far down that the measuring point just touches the surface of the glass. If the screw is turned to far, the whole apparatus either starts turning or starts to wobble.
- Turn the circular scale so that the setting is 0.

2.2 Measuring plate thickness and depressions

- After setting the zero point, perform the measurement as described
- Read the value in mm from the vertical scale and fractions from the disc.

2.3 Measuring radii of curvature of spherical surfaces

- After setting the zero point, place the spherometer on the spherical surface so that the four steel tips all touch the surface evenly.
- The radius of curvature is given by:

$$R = \frac{a^2}{2e} + \frac{e}{2}$$

where e = scale reading and a = the distance between one of the steel tips and the measuring tip.

- Check the separation a to ensure accuracy of measurements.

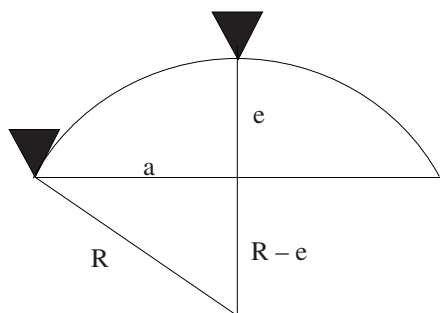

Convex surface

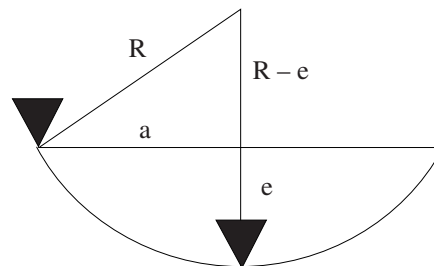

Concave surface