

U10345 Fresnel mirror

Instruction Sheet

11/04 MH

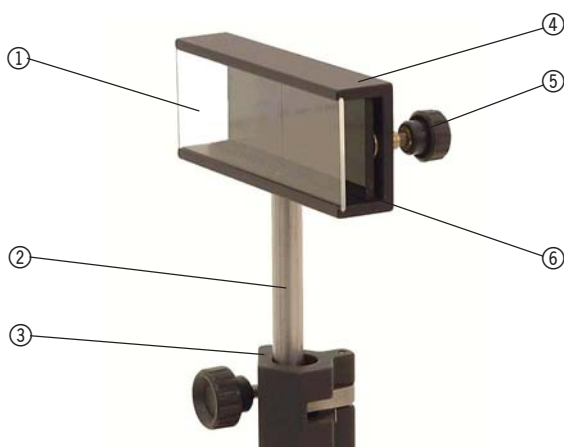

Fig. 1: Components

- ① Protective window pane made of plexiglass
- ② Stand rod, 10 mm diameter made of stainless steel
- ③ Optical rider (not contained in the scope of supply)
- ④ Housing made of black anodized aluminum
- ⑤ Knurled screw for mirror adjustment
- ⑥ Surface-coated mirror made of black acrylic

Using the Fresnel mirror you can perform experiments on interference of monochromatic, coherent light, whereby thanks to having two mirrors it is possible to produce two virtual light sources – which then interfere with each other – from a single light source.

1. Safety instructions

- When using a laser it is imperative that all associated safety instructions specified for the device be strictly complied with, e.g. do NOT stare into the laser beam!
- During the experiment none of the observers may experience glare.

2. Description

Fresnel's idea of bringing about interference in light waves reflecting off two mirrors is depicted in Fig. 2. The light propagating from one point light source P (parallel laser beam with lens connected upstream) is reflected by two mirrors in such a manner that the two partial beams are superimposed on each other, thus causing interference. The experiment evaluation can easily be undertaken using mathematical methodology or graphically in physical terms simply by determining the separation of the two virtual point light sources P_1 and P_2 and then calculating the interference

pattern as a superimposing of circular waves arising from P_1 and P_2 .

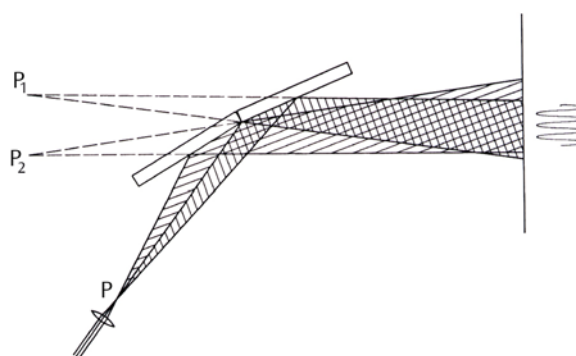

Fig. 2: Operating principle of the Fresnel mirror.

The Fresnel mirror consists of two acrylic half mirrors each 29 mm x 45 mm in size. Since the experiments call for a grazing incidence of light to be set, the result is total reflection and the acrylic glass functions like a surface-coated mirror. One of the two mirrors is permanently attached inside the housing while the other mirror is adjustable and can be tilted by an angle of approx. -0.5° up to $+2^\circ$. There is a protective window pane made of plexiglass positioned in front of the mirrors, which may not be removed during the experiments. This is designed to protect against accidental

contact to the mirrors. The stand rod has a diameter of 10 mm and is scaled lengthwise so that the mirror's center point has a standard height of 150 mm.

3. Operation and maintenance

- The Fresnel mirror is operated using grazing light incidence, whereby it is tilted by approx. 1° - 2° with respect to the light beam. After adjusting the light source so that both mirrors are illuminated with equal luminous intensity, the inclination of the two reflected light beams can be adjusted with respect to each other by turning the knurled screw ⑤.
- **Maintenance:** the Fresnel mirror is basically maintenance-free. To clean simply wipe clean using a damp rag with detergent. If possible the mirror should only be dry dusted using a soft brush. If necessary it can also be cleaned with a detergent and a soft rag.
- **Storage:** this device should be stored in a dust-free location, perhaps completely covered with a plastic bag.

4. Experiment procedure and evaluation

- There are two experiment setups described below. In Section 4.1 a simple and compact assembly is presented which leads to thick and bright interference bands, but which have previously not been quantitatively evaluated. Section 4.2 shows the assembly for the "classical" experiment and has a basic evaluation example.

4.1 Compact, qualitative interference experiment

- Following equipment is required:
 - 1 x U10302 Optical bench with triangular profile, 0.5 m long
 - 1 x U10312 Optical rider, 120 mm high, 50 mm wide
 - 1 x U10311 Optical rider, 90 mm high, 50 mm wide
 - 2 x U10310 Optical rider, 60 mm high, 50 mm wide
 - 1 x U10331 Extension arm
 - 1 x U43001 He-Ne laser
 - 1 x U10345 Fresnel mirror
 - 1 x Diverging lens, e.g. $f = 5$ mm
 - 1 x U17125 Observation screen
- The experiment setup can be seen in Fig. 3. The Fresnel mirror is tilted by approx. 1° with respect to the laser. Initially the lens is still pivoted out of the beam. By turning the laser in the optical rider the beam is adjusted so that it incidents on both mirrors and produces two equally bright points on the observation screen (if necessary, slightly adjust the mirror tilt by turning the knurled screw ⑤). Then by turning the knurled screws you can adjust the two points on the screen until they are coincident. If you now pivot the lens into the beam axis, an interference pattern should already appear on the screen, which then can be made even sharper still by readjusting the laser.



Fig. 3: Experiment setup "Compact Interference Experiment"

4.2 Classical interference experiment

4.2.1 Experiment setup

- 1 x U10302 Optical bench with triangular profile, 0.5 m long
- 1 x U10312 Optical rider, 120 mm high, 50 mm wide
- 1 x U10311 Optical rider, 90 mm high, 50 mm wide
- 2 x U10310 Optical rider, 60 mm high, 50 mm wide
- 1 x U43001 He-Ne laser
- 1 x U10345 Fresnel mirror
- 1 x Diverging lens, e.g. $f = 5$ mm
- 1 x U17104 Convex lens, $f = 200$ mm
- The experiment setup can be seen in Fig. 4. At first the laser and the diverging lens are mounted and aligned so that the laser beam diverged by the lens propagates almost parallel to the optical bench. The beam trajectory can be made visible using a sheet of paper. Do not look directly into the beam! Subsequently the Fresnel mirror is mounted at an inclination of around 1° - 2° with respect to the laser.
- By turning the knurled screw ⑤ an image should now appear in focus on the screen 2 - 3 m meters away which basically corresponds to Fig. 5. There will still be visible a bright area next to the interference pattern, which stems from the light which misses the mirrors. Besides the bands of the actual interference pattern it is possible to see still more interference bands and rings depending on the quality and degree of cleanliness of the laser and lens. A definitive conclusion regarding which bands are actually caused by the mirrors is easy to obtain simply by adjusting the knurled screw ⑤. Only the bands which vary their width during this adjustment are "real" interference bands. Their distance should be adjustable from approx. 1 - 4 mm.



Fig. 4: Experiment setup "Classical Interference Experiment". Position of components (left edge of the optical rider): laser: 0 mm, lens $f = 5$ mm: 150 mm, Fresnel mirror: 220 mm, lens $f = 200$ mm (only mounted when the distance to the virtual light source is measured): approx. 380 mm. The interference image is obtained on the screen (or a brightly lit wall) at a distance of 2 to 3 m.

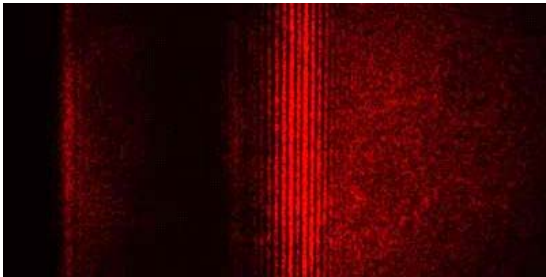

Fig. 5: Interference image on the observation screen. A bright band can still be discerned at the left edge, which stems from the light that does not hit the mirror.

4.2.2 Experiment procedure

- During one experiment the separation D of the interference bands is determined first. If the separation amounts to, for example, 24 ± 1 mm between 7 maxima, then $D = 3.43$ mm.
- Afterwards the 200 mm lens is mounted and, if needed, somewhat shifted until two clearly discernible light spots appear on the screen with a distance of about 3 - 15 mm from each other (the light missing the mirror produces a third spot at a greater distance farther to the left). Here it may be beneficial for the measurement if the light spots are somewhat larger than the minimum size obtained when the lens is sharply focussed. In this example the distance of the light spots amounts to $A = 6.8$ mm and was determined using a measurement caliper.
- The last variable needed for the evaluation is the distance b between the 200 mm lens and the observation screen ($b = 2700$ mm).

4.2.3 Experiment evaluation

- As was already explained on the basis of Fig. 2, the interference image can be interpreted as the superimposing of the light from two point light sources P_1 and P_2 . In order for an intensity maximum to be produced on the observation screen the ray's path difference d between two beams originating from P_1 and P_2 must correspond precisely to the wavelength λ or a multiple integer of λ . Using the variables defined in Fig. 6 we obtain the following

$$\frac{d}{a} = \sin \varphi \quad (1)$$

and

$$\frac{D}{L} = \tan \varphi \quad (2)$$

- At a sufficiently low angle φ it holds true that $\sin \varphi \approx \tan \varphi$. Furthermore let us assume that $d = \lambda$ (first maximum). As a result it follows from Equations 1 and 2 that:

$$\lambda = a \frac{D}{L} \quad (3)$$

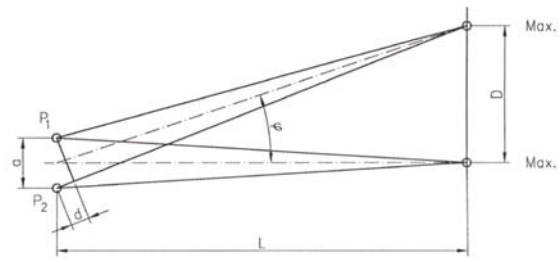

Fig. 6: Intensity maxima arise when $d = n \lambda$ (n being an integer).

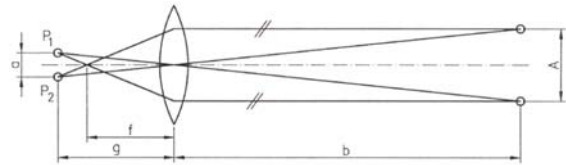

Fig. 7: Determination of the separation a between the virtual point light sources using a lens (e.g. $f = 200$ mm). The distances A and b are measured.

- The determination of the separation a of the virtual point light sources is depicted in Fig. 7. By using the intercept theorems we directly obtain the two correlations

$$\frac{a}{A} = \frac{g}{b} \quad (4)$$

and

$$\frac{a}{A} = \frac{g-f}{f} \quad (5)$$

- Equalizing the two equations for the elimination of a/A and resolving for g results in

$$g = \frac{bf}{b-f} \quad (6)$$

- If this is inserted in Equation 4, a can be determined and inserted in Eq. 3. The still missing value for the length L in Eq. 3 results according to Fig. 7 from the sum of the two distances g and b . When everything is inserted into Eq. 3 it yields:

$$\lambda = \frac{ADF}{b^2}$$

- For the example the result is $\lambda = 640$ nm, which is in good agreement with the manufacturer's specifications for the laser being used (632.8 nm).

