

Bolometer U8461300

Instruction sheet

07/08 ALF

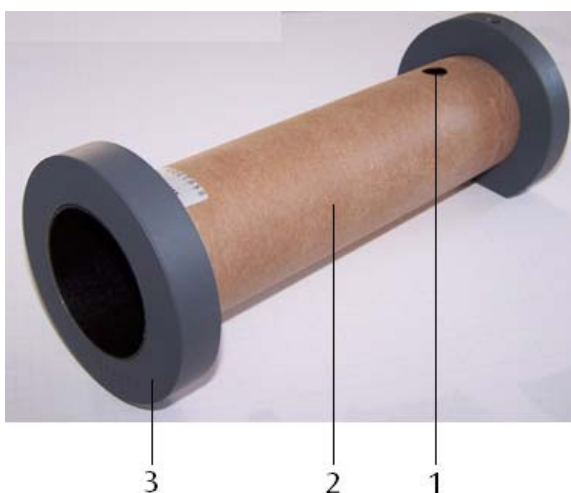

- 1 Hole for thermometer
- 2 Cardboard tube
- 3 End-plate

1. Description

A bolometer is used for measuring the heat radiation from the sun.

The instrument consists of a solid aluminium cylinder with a blackened end surface inside a cardboard tube, which is blackened on its inner surface and has two plastic end-plates. A hole is provided in the tube and the cylinder for inserting a thermometer.

The blackened surface of the aluminium cylinder prevents reflection of the incoming heat radiation, and a blackened cardboard tube screens the cylinder from ambient background radiation.

2. Technical data

Aluminium cylinder:	≈ 30 mm × 40 mm Ø
Cardboard tube:	≈ 195 mm × 50 mm Ø
Weight:	350 g approx.

3. Sample experiments

To carry out the experiments the following equipment is required in addition:

1 Thermometer +10 ... +30 °C	U8451700
1 Tripod stand, 150 mm	U13270
1 Stand rod, 470 mm	U15002
1 Universal jaw clamp	U13261
1 Universal clamp	U13255
1 Digital stopwatch	U11902
1 Set of Vernier callipers, 150 mm	U10071
1 Electronic scale, 2500 g	U42058
1 Pipette dropper	

3.1 Measuring the quantity of heat transferred to an aluminium body by solar radiation

Heat from the sun is transmitted to the earth by thermal radiation. The intensity of the thermal radiation depends on the position of the sun above the horizon and the clarity of the atmosphere. The earth's atmosphere "swallows up" a fraction of the solar radiation. That fraction may be smaller according to how clear the weather is and how high the sun is in the sky.

- Set up the bolometer as shown in Figure 1, using the stand, rod and clamps.
- Adjust the bolometer so that the sunlight shines exactly along its axis. The shadow of the front end-plate should then fall exactly onto the rear end-plate.
- Before inserting the thermometer into the hole in the aluminium cylinder, put in a few drops of water to improve the transfer of heat.
- Insert the thermometer into the hole, read the initial temperature, and record it in a table.
- In a series of measurements over a period of 10 minutes, read the temperature at intervals of 60 seconds and record the values.
- Remove the rear end-plate, unscrew the aluminium cylinder, and determine its mass m by weighing.
- Using the callipers, measure the diameter d of the blackened surface and calculate the area A .
- Plot a graph of temperature against time to show the heating-up of the aluminium cylinder. Draw a line of best fit through the data points.

The temperature rise per minute, ΔT , is obtained from the gradient of the line.

The quantity of heat Q received by the blackened surface of the aluminium cylinder in one minute can be calculated from the temperature rise per minute ΔT , the mass m of the cylinder, and the specific heat capacity of aluminium c_{Al} :

$$Q = c_{Al} \cdot m \cdot \Delta T \quad (1)$$

The specific heat capacity of aluminium is

$$c_{Al} = 896 \frac{\text{J}}{\text{kg} \cdot ^\circ\text{C}}.$$

- Using Equation 2, calculate the radiation power per unit area (heat input per cm^2 per minute).

$$S = \frac{Q}{A} \quad (2)$$

3.2 Measuring the radiation power of a filament lamp

Additional equipment needed:

- | | |
|---|------------|
| 1 E14 lamp socket | U8495320 |
| 1 Filament lamp 12 V, 25 W, type E14 as sold for domestic use | |
| 1 Transformer with rectifier (230 V, 50/60 Hz) | U33300-230 |
| or | |
| 1 Transformer with rectifier (115 V, 50/60 Hz) | U33300-115 |

Experiment leads

Air is a poor conductor of heat, and therefore thermal conduction makes only a very small contribution in this experiment. Furthermore, as the heated air near the lamp flows upward and not towards the “black body”, thermal convection also makes no significant contribution to the heating of the aluminium cylinder.

- Screw the filament lamp into the lamp socket and connect to the power supply.
- Remove the cardboard tube and support the aluminium cylinder with one end-plate using a stand and clamp (Fig. 2).
- Position the aluminium cylinder so that its distance l from the lamp filament is about 4 cm.
- Determine the quantity of heat per minute and the radiation power per unit area in the same way as in Experiment 3.1.

If the lamp filament is regarded as a point source of radiation, the total radiation power S_G that is emitted by the lamp is the amount received by a sphere of radius $r = l$. Therefore it is the product of the calculated radiation power per unit area, S , and the surface area of the sphere A_0 :

$$S_G = A_0 \cdot S$$

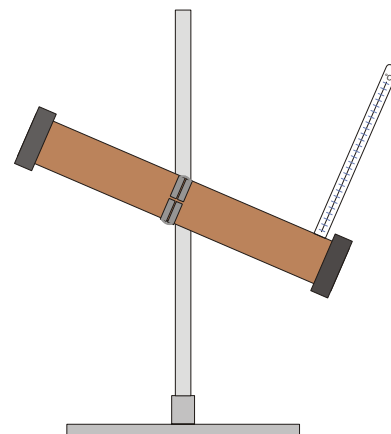

Fig. 1 Measuring the radiation power of the sun

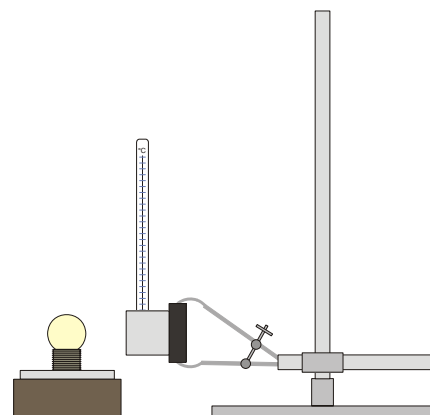

Fig. 2 Measuring the radiation power of a filament lamp