

## 12-V DC motor with non-ferrous rotor U8552330

### Instruction sheet

02/08 DML/ALF

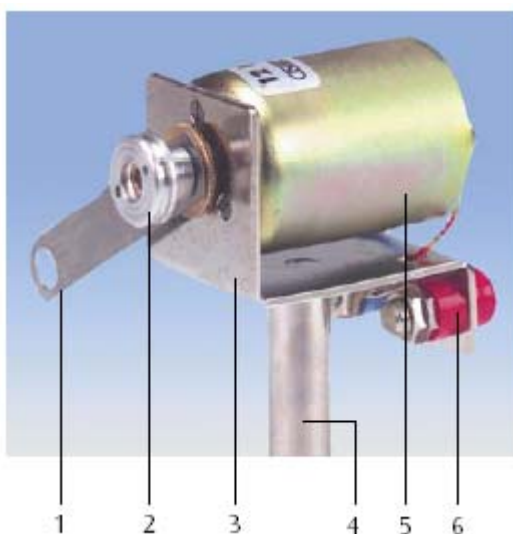

- 1 Lever
- 2 Pulley
- 3 Supporting holder
- 4 Stem
- 5 Motor
- 6 4-mm connectors

### 1. Safety instructions

- Do not exceed the maximum permissible operating parameters (see Section 3 – Technical data).

Long hair, loose clothing, or jewellery could get caught and entangled in the rotating components.

- To prevent this danger, it is advisable to wear a hairnet in the case of long hair.
- Do not wear unsuitable clothing or jewellery.

While operating with the belt pulley and the drive belt, there is the additional danger that parts of the body, e.g. fingers, may get pulled in or caught between the belt and the pulley.

- Do not touch or hold any rotating components of the experiment set-up.

The DC motor can also be used as a generator.

- In this state, do not connect any power supply to the connectors.

### 2. Description

The DC motor is a small, compact motor with a non-ferrous rotor and is used as an excitation unit in experiments on mechanics, simple harmonic oscillation and electricity. It can also be used as a tachometer. Its low moment of inertia, in conjunction with a high starting torque, provides a short acceleration time. Owing to the strong permanent magnet of the stator, the motor is highly efficient. The special brush and commutator arrangement, in conjunction with friction bearings, guarantees a long working life and low running noise.

The axle of the motor is equipped with a threaded bush to which a pulley is attached by means of a thread. This pulley allows other wheels and levers to be attached to the axle for the excitation of mechanical oscillations and waves.

The DC motor is attached to an angled supporting bracket with stem. 4-mm connectors on the bracket are responsible for supplying the equipment with electricity as well as for tapping the output voltage in generator mode.

### 3. Technical data

Nominal voltage:	12 V DC
Max. permissible operating voltage:	15 V DC
Idling speed:	3800 rpm
Nominal speed at rated torque:	3100 rpm/5 mNm
Nominal current without load/ with nominal load:	55 / 210 mA
Power consumption:	2.9 W
Voltage per speed of rotation:	$3.6 \dots 4.4 \frac{mV}{rpm}$

Rotor impedance:	12 $\Omega$
Starting torque:	29 mNm
Acceleration time (no-load):	12.5 ms
Direction of rotation:	Reversible
Max. permissible bearing load:	
radial at shaft-end:	5.0 N
axial:	0.5 N

\*In the case of older motor models from an earlier range, the voltage sensitivity is in the range of:

$$2.8 \dots 3.6 \frac{mV}{rpm}$$

### 4. Sample experiments

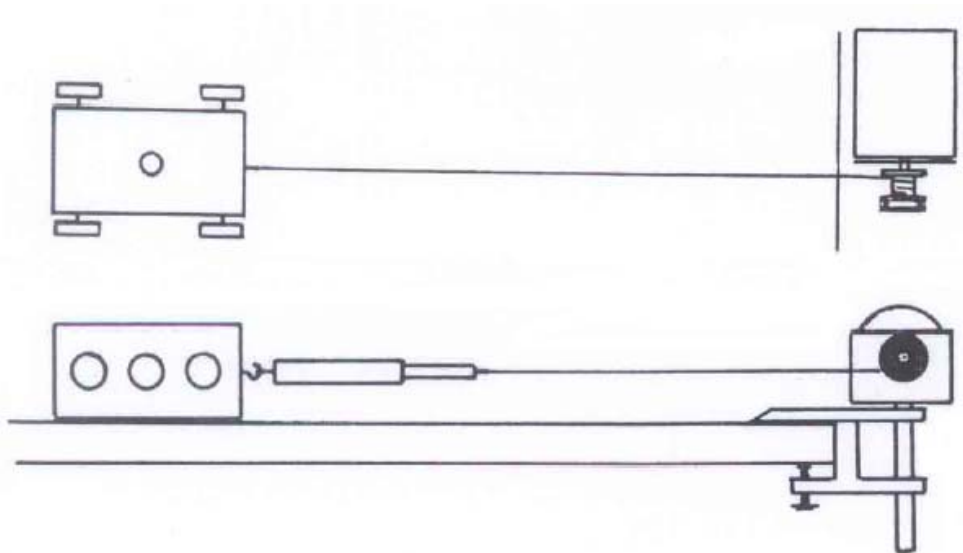

Fig. 1: Experiments on uniform motion (top) and friction (bottom)

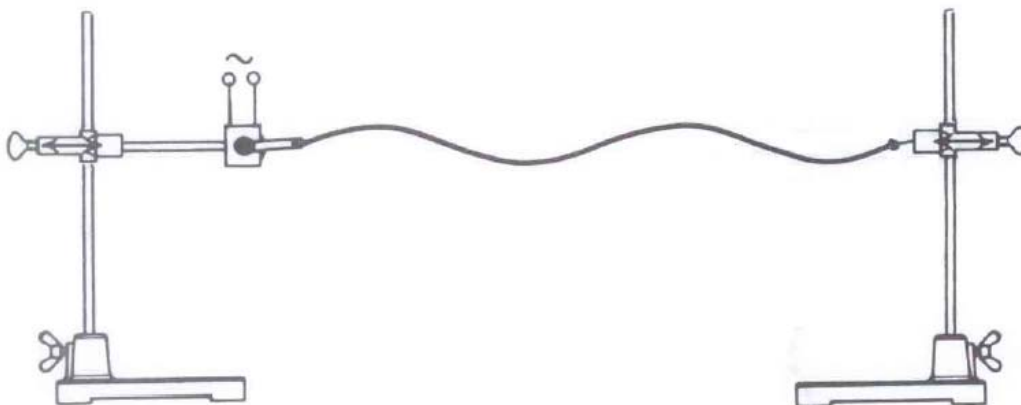

Fig. 2: Excitation of transverse waves in a rubber band using a sine wave generator

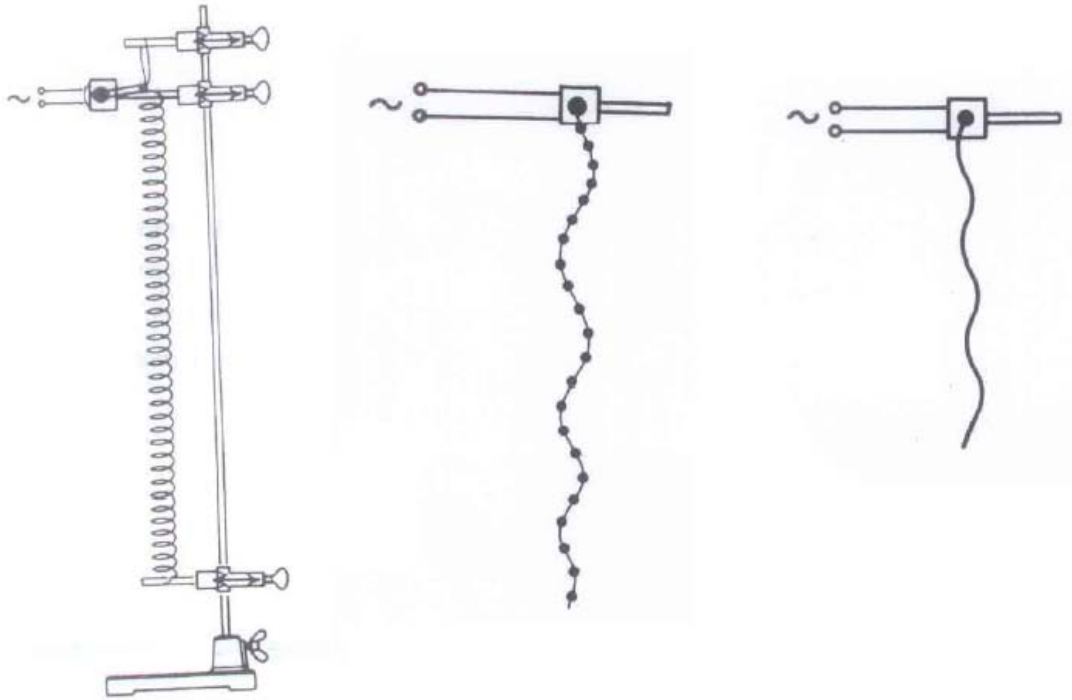

Fig. 3 (left): Excitation of longitudinal waves in a helical spring  
 Fig. 3 (centre and right): Excitation of transverse waves in a suspended chain and a leaf spring using a sine wave generator

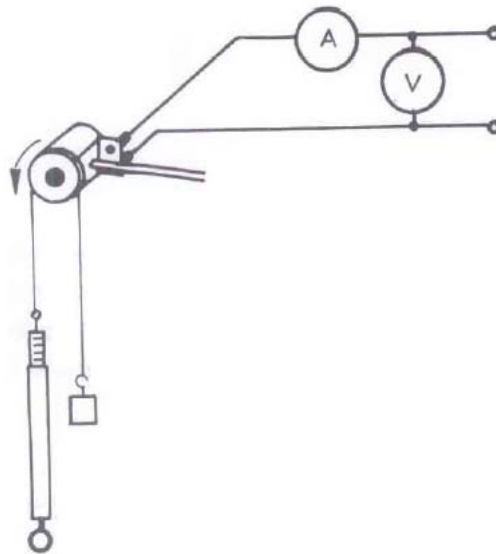

Fig. 4 : Determining the efficiency of the motor

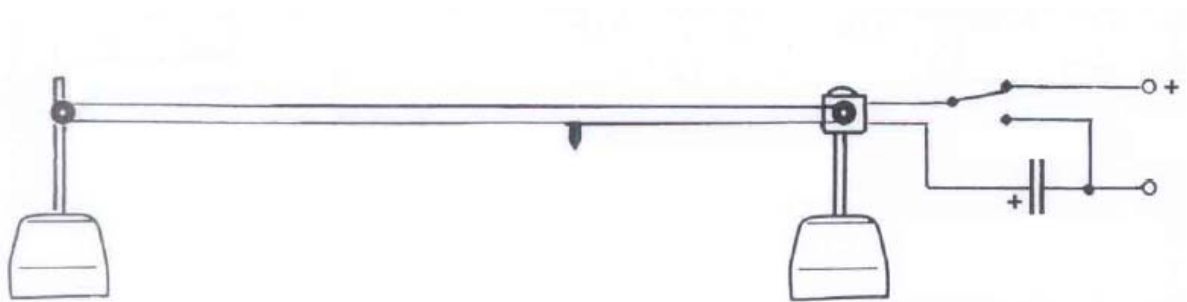

Fig. 5: Energy in a capacitor (energy input is equal to the energy output)

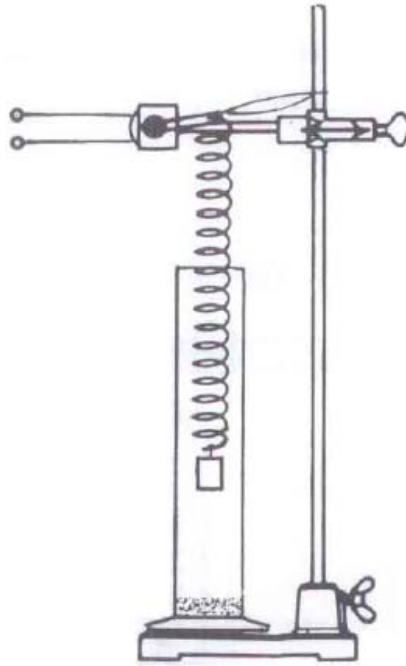

Fig. 6: Forced oscillation in a spring pendulum

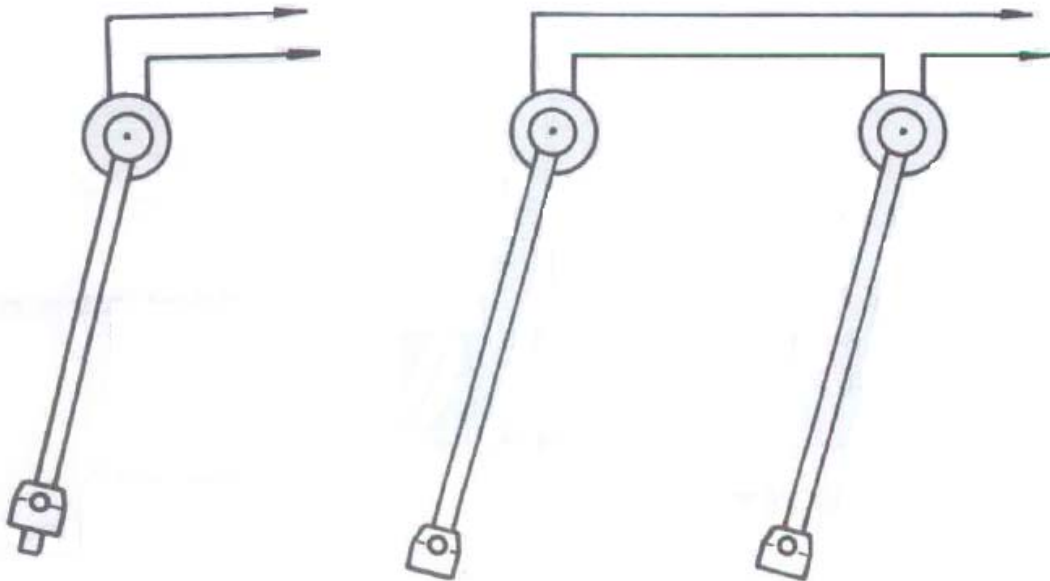

Fig. 7 (left): Recording mechanical oscillations of a rodpendulum with an XY plotter  
Fig. 7 (right): Recording the superimposition of synchronised oscillations with an XY plotter